

2000-2003



HONDA

SERVICE MANUAL

CR125R

IMPORTANT SAFETY NOTICE

 **WARNING** *Indicates a strong possibility of severe personal injury or death if instructions are not followed.*

CAUTION: *Indicates a possibility of equipment damage if instructions are not followed.*

NOTE: Gives helpful information.

Detailed descriptions of standard workshop procedures, safety principles and service operations are not included. It is important to note that this manual contains some warnings and cautions against some specific service methods which could cause **PERSONAL INJURY** to service personnel or could damage a vehicle or render it unsafe. Please understand that those warnings could not cover all conceivable ways in which service, whether or not recommended by Honda, might be done or of the possibly hazardous consequences of each conceivable way, nor could Honda investigate all such ways. Anyone using service procedures or tools, whether or not recommended by Honda, *must satisfy himself thoroughly* that neither personal safety nor vehicle safety will be jeopardized by the service methods or tools selected.

HOW TO USE THIS MANUAL

This service manual describes the service procedures for the CR125R.

Follow the Maintenance Schedule recommendations (page 3-3) to ensure that the motorcycle is always in peak operating condition.

Sections 1 and 3 apply to the whole motorcycle. Section 2 describes procedures for removal/installation of components that may be required to perform service described in the following sections.

Sections 4 through 15 describe parts of the motorcycle, grouped according to location.

Find the section you want on this page, then turn to the table of contents on the first page of the section.

Most sections start with an assembly or system illustration, service information and troubleshooting for the section.

The subsequent pages give detailed procedures.











If you don't know the source of the trouble, go to section 17, Troubleshooting.

CONTENTS

	GENERAL INFORMATION	1
	FRAME/BODY PANELS/EXHAUST SYSTEM	2
	MAINTENANCE	3
ENGINE AND DRIVE TRAIN	FUEL SYSTEM	4
	COOLING SYSTEM	5
	ENGINE REMOVAL/INSTALLATION	6
	CYLINDER HEAD/CYLINDER/PISTON	7
	RC VALVE	8
	CLUTCH/KICKSTARTER/GEARSHIFT LINKAGE	9
	CRANKCASE/CRANKSHAFT/TRANSMISSION	10
	FRONT WHEEL/SUSPENSION/STEERING	11
	REAR WHEEL/SUSPENSION	12
	HYDRAULIC BRAKE	13
ELECTRICAL	IGNITION SYSTEM/ALTERNATOR	14
	WIRING DIAGRAM	15
	TECHNICAL FEATURES	16
	TROUBLESHOOTING	17
	INDEX	18

SYMBOLS

The symbols used throughout this manual show specific service procedures. If supplementary information is required pertaining to these symbols, it would be explained specifically in the text without the use of the symbols.

	Replace the part(s) with new one(s) before assembly.
	Use recommended engine oil, unless otherwise specified.
	Use molybdenum oil solution (mixture of the engine oil and molybdenum grease in a ratio of 1 : 1).
	Use multi-purpose grease (Lithium based multi-purpose grease NLGI #2 or equivalent).
	Use molybdenum disulfide grease (containing more than 40% molybdenum disulfide, NLGI #2 or equivalent). Example: Molykote® BR-2 plus manufactured by Dow Corning, U.S.A. Multi-purpose M-2 manufactured by Mitsubishi Oil Japan
	Use molybdenum disulfide grease (containing more than 3% molybdenum disulfide, NLGI #2 or equivalent). Example: Molykote® BR-2 plus manufactured by Dow Corning, U.S.A. Honda Moly 60 (U.S.A only) Rocol ASP manufactured by Rocol Limited, U.K. Rocol Paste manufactured by Sumico Lubricant, Japan
	Use silicone grease.
	Apply a locking agent. Use a middle strength locking agent unless otherwise specified.
	Apply sealant.
	Use brake fluid, DOT 4. Use the recommended brake fluid, unless otherwise specified.
	Use Fork or Suspension Fluid.

1. GENERAL INFORMATION

GENERAL SAFETY	1-1	TOOLS	1-16
SERVICE RULES	1-2	LUBRICATION & SEAL POINTS	1-18
MODEL IDENTIFICATION	1-3	CABLE & HARNESS ROUTING	1-20
SPECIFICATIONS	1-4	OPTIONAL PARTS	1-26
TORQUE VALUES	1-13		

GENERAL SAFETY

CARBON MONOXIDE

If the engine must be running to do some work, make sure the area is well ventilated. Never run the engine in an enclosed area.

▲ WARNING

The exhaust contains poisonous carbon monoxide gas that can cause loss of consciousness and may lead to death.

Run the engine in an open area or with an exhaust evacuation system in an enclosed area.

GASOLINE

Work in a well ventilated area. Keep cigarettes, flames or sparks away from the work area or where gasoline is stored.

▲ WARNING

Gasoline is extremely flammable and is explosive under certain conditions. KEEP OUT OF REACH OF CHILDREN.

HOT COMPONENTS

▲ WARNING

Engine and exhaust system parts become very hot and remain hot for some time after the engine is run. Wear insulated gloves or wait until the engine and exhaust system have cooled before handling these parts.

USED ENGINE OIL

▲ WARNING

Used engine oil may cause skin cancer if repeatedly left in contact with the skin for prolonged periods. Although this is unlikely unless you handle used oil on a daily basis, it is still advisable to thoroughly wash your hands with soap and water as soon as possible after handling used oil. KEEP OUT OF REACH OF CHILDREN.

BRAKE DUST

Never use an air hose or dry brush to clean the brake assemblies. Use OSHA-approved vacuum cleaner or alternate method approved by OSHA, designed to minimize the hazard caused by airborne asbestos fibers.

BRAKE FLUID

CAUTION:

Spilling fluid on painted, plastic or rubber parts will damage them. Place a clean shop towel over these parts whenever the system is serviced. KEEP OUT OF REACH OF CHILDREN.

GENERAL INFORMATION

COOLANT

Under some conditions, the ethylene glycol in engine coolant is combustible and its flame is not visible. If the ethylene glycol does ignite, you will not see any flame, but you can be burned.

▲ WARNING

- **Avoid spilling engine coolant on the exhaust system or engine parts. They may be hot enough to cause the coolant to ignite and burn without a visible flame.**
- **Coolant (ethylene glycol) can cause some skin irritation and is poisonous if swallowed. KEEP OUT OF REACH OF CHILDREN.**
- **Do not remove the radiator cap when the engine is hot. The coolant is under pressure and could scald you.**

CAUTION:

Using coolant with silicate inhibitors may cause premature wear of water pump seals or blockage of radiator passages. Using tap water may cause engine damage.

If it contacts your skin, wash the affected areas immediately with soap and water. If it contacts your eyes, flush them thoroughly with fresh water and get immediate medical attention. If it is swallowed, the victim must be forced to vomit then rinse mouth and throat with fresh water before obtaining medical attention. Because of these dangers, always store coolant in a safe place, always from the reach of children. Recycle used coolant in an ecologically correct manner.

SERVICE RULES

1. Use genuine HONDA or HONDA-recommended parts and lubricants or their equivalents. Parts that don't meet HONDA's design specifications may cause damage to the motorcycle.
2. Use the special tools designed for this product to avoid damage and incorrect assembly.
3. Use only metric tools when servicing the motorcycle. Metric bolts, nuts and screws are not interchangeable with English fasteners.
4. Install new gaskets, O-rings, cotter pins, and lock plates when reassembling.
5. When tightening bolts or nuts, begin with the larger diameter or inner bolt first. Then tighten to the specified torque diagonally in incremental steps unless a particular sequence is specified.
6. Clean parts in cleaning solvent upon disassembly. Lubricate any sliding surfaces before reassembly.
7. After reassembly, check all parts for proper installation and operation.
8. Route all electrical wires as show on pages 1-18 through 1-20, Cable and Harness Routing.

NITROGEN PRESSURE

For shock absorber with a gas-filled reservoir.

▲ WARNING

- **Use only nitrogen to pressurize the shock absorber. The use of an unstable gas can cause a fire or explosion resulting in serious injury.**
- **The shock absorber contains nitrogen under high pressure. Allowing fire or heat near the shock absorber could lead to an explosion that could result in serious injury.**
- **Failure to release the pressure from a shock absorber before disposing of it may lead to a possible explosion and serious injury if it is heated or pierced.**

To prevent the possibility of an explosion, release the nitrogen by pressing the valve core. Then remove the valve stem from the shock absorber reservoir. Dispose of the oil in a manner acceptable to the Environmental Protection Agency (EPA).

Before disposal of the shock absorber, release the nitrogen by pressing the valve core. Then remove the valve stem from the shock absorber.

MODEL IDENTIFICATION

2000 SHOWN (After 2000 models look similar)

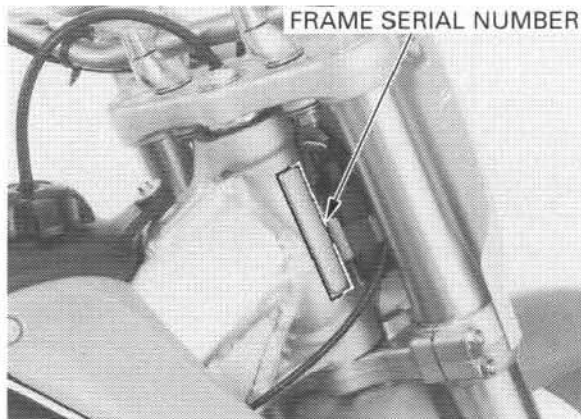

(1) The frame serial number is stamped on the right side of the steering head.

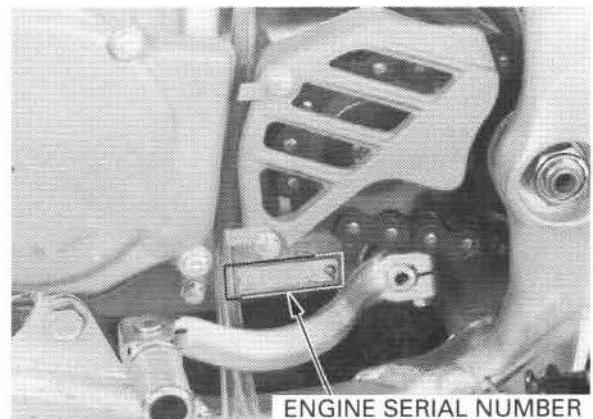

(2) The engine serial number is stamped on the left side of the crankcase.

2000 – 2001:

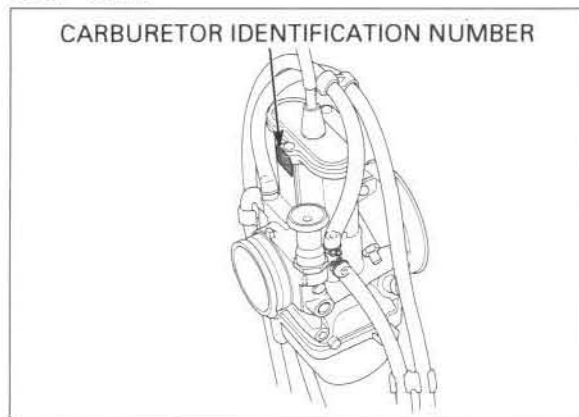

After 2001:

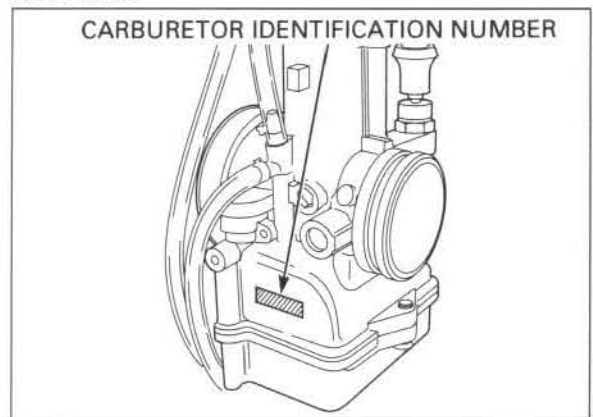

(3) The carburetor identification number is stamped on the engine side (After 2001: right side) of the carburetor body.

GENERAL INFORMATION

SPECIFICATIONS

GENERAL			
	ITEM		SPECIFICATIONS
DIMENSIONS	Overall length	2000:	2,169 mm (85.3 in)
		2001:	2,173 mm (85.6 in)
		After 2001:	2,151 mm (84.7 in)
	Overall width		823 mm (32.4 in)
		After 2001:	826 mm (32.5 in)
	Overall height	2000:	1,283 mm (50.5 in)
		2001:	1,271 mm (50.0 in)
		After 2001:	1,278 mm (50.3 in)
	Wheelbase	2000:	1,467 mm (57.8 in)
		2001:	1,471 mm (57.9 in)
	After 2001:	1,458 mm (57.4 in)	
Seat height	2000:	942 mm (37.1 in)	
	2001:	936 mm (36.9 in)	
	After 2001:	947 mm (37.3 in)	
Footpeg height	2000:	420 mm (16.5 in)	
	2001:	414 mm (16.3 in)	
	After 2001:	434 mm (17.1 in)	
Ground clearance	2000:	340 mm (13.4 in)	
	2001:	332 mm (13.1 in)	
	After 2001:	345 mm (13.6 in)	
	Dry weight		87.5 kg (193.0 lbs)
FRAME	Frame type		Twin-tube
	Front suspension		Telescopic fork
	Front wheel axle travel	2000:	281.9 mm (11.1 in)
		2001:	280 mm (11.0 in)
		After 2001:	272 mm (10.7 in)
	Front suspension cushion stroke	2000 – 2001:	315 mm (12.4 in)
		After 2001:	305 mm (12.0 in)
	Rear suspension		Swingarm/Pro-Link
	Rear wheel axle travel	2000:	323 mm (12.7 in)
		2001:	319 mm (12.6 in)
		After 2001:	318 mm (12.5 in)
	Rear damper		Decarbon type with nitrogen gas filled damper
	Front tire size		80/100-21 51M
	Rear tire size		100/90-19 57M
	Tire brand		
	Dunlop		Front: K490C/Rear: K695
	Front brake		Hydraulic single disc
	Front brake swept area		334.5 cm ² (51.8 in ²)
	Rear brake		Hydraulic single disc
	Rear brake swept area	2000 – 2001:	334.5 cm ² (51.8 in ²)
	After 2001:	391.1 cm ² (60.6 in ²)	
Caster angle	2000:	26° 21'	
	2001:	27° 3'	
	After 2001:	25° 54'	
Trail length	2000:	111 mm (4.4 in)	
	2001:	116 mm (4.6 in)	
	After 2001:	101 mm (4.0 in)	
Fuel tank capacity	2000 – 2001:	7.5 liter (2.0 US gal, 1.6 Imp gal)	
	After 2001:	7.7 liter (2.0 US gal, 1.7 Imp gal)	

GENERAL INFORMATION

Unit: mm (in)

LUBRICATION SYSTEM		STANDARD	SERVICE LIMIT
ITEM			
Recommended engine oil		Pro-Honda HP2 2-stroke oil or equivalent motor oil	—
Fuel/oil mixing ratio		32:1	—
Transmission oil capacity	at draining	0.57 liter (0.60 US qt, 0.50 Imp qt)	—
	at disassembly	0.65 liter (0.69 US qt, 0.57 Imp qt)	—
Recommended transmission oil		Pro-Honda HP Trans Oil, Pro-Honda GN4 4-stroke Oil or equivalent motor oil API service classification SF or SG Viscosity: SAE 10W-40	—

FUEL SYSTEM		SPECIFICATIONS
ITEM		
Carburetor identification number	2000:	TMX01A
	2001:	TMX01B
	After 2001:	TMX02A
Main jet	2000:	#360
	2001:	#380
	After 2001:	#400
Slow jet	2000:	#50
	2001:	#45
	After 2001:	#32.5
Jet needle	2000:	6BEG20 – 69
	2001:	6BEG20 – 68
	After 2001:	6DFY5 – 74
Jet needle clip position		3rd groove from top
Air screw initial opening	2000:	1-3/4 turns out
	2001:	2-1/4 turns out
	After 2001:	2-1/8 turns out
Float level	2000 – 2001:	15.0 mm (0.59 in)
	After 2001:	7.5 mm (0.30 in)
Throttle grip free play		3 – 5 mm (1/8 – 1/4 in)
Reed valve clearance service limit		0.2 mm (0.01 in)

COOLING SYSTEM		SPECIFICATIONS
ITEM		
Coolant capacity	at change	0.88 liter (0.930 US qt, 0.774 Imp qt)
	at disassembly	0.97 liter (1.025 US qt, 0.854 Imp qt)
Radiator cap relief pressure		108 – 137 kPa (1.1 – 1.4 kgf/cm ² , 16 – 20 psi)
Recommended antifreeze		Pro Honda HP Coolant or an equivalent high quality ethylene glycol antifreeze containing silica-free corrosion inhibitors

GENERAL INFORMATION

Unit: mm (in)

CYLINDER HEAD/CYLINDER/PISTON			STANDARD	SERVICE LIMIT
ITEM				
Cylinder head warpage			—	0.05 (0.002)
Cylinder	I.D.	A	53.976 – 53.983 (2.1250 – 2.1253)	54.013 (2.1265)
		B	53.968 – 53.976 (2.1247 – 2.1250)	54.006 (2.1262)
	Out of round		—	0.05 (0.002)
	Taper		—	0.05 (0.002)
	Warpage		—	0.05 (0.002)
Piston, piston rings	Piston mark direction		"IN" mark facing toward the intake side	—
	Piston O.D.	A	53.933 – 53.940 (2.1233 – 2.1236)	53.883 (2.1214)
		B	53.925 – 53.933 (2.1230 – 2.1233)	53.875 (2.1211)
	Piston O.D. measurement point		15mm (0.59 in) from bottom of skirt	—
	Piston pin bore I.D.		15.002 – 15.015 (0.5906 – 0.5911)	15.035 (0.5919)
	Piston pin O.D.		14.994 – 15.000 (0.5903 – 0.5906)	14.98 (0.590)
	Piston-to-piston pin clearance		0.002 – 0.021 (0.0001 – 0.0008)	0.03 (0.001)
	Piston ring-to-ring groove clearance		0.045 – 0.080 (0.002 – 0.003)	0.09 (0.004)
	Piston ring end gap		0.40 – 0.55 (0.016 – 0.022)	0.65 (0.026)
Cylinder-to-piston clearance			0.035 – 0.050 (0.0014 – 0.0020)	0.07 (0.003)
Connecting rod small end I.D.			19.002 – 19.014 (0.7481 – 0.7486)	19.022 (0.7489)

Unit: mm (in)

CLUTCH/KICKSTARTER/GEARSHIFT LINKAGE			STANDARD	SERVICE LIMIT
ITEM				
Clutch lever free play			10 – 20 (3/8 – 3/4)	—
Clutch spring free length			37.1 (1.46)	35.2 (1.39)
Clutch outer guide I.D.			20.000 – 20.021 (0.7874 – 0.7882)	20.05 (0.789)
Clutch disc thickness			2.92 – 3.08 (0.114 – 0.121)	2.85 (0.112)
Clutch plate warpage			—	0.15 (0.006)
Kickstarter pinion gear I.D.			16.516 – 16.534 (0.6502 – 0.6509)	16.55 (0.652)
Kickstarter spindle O.D.			16.466 – 16.484 (0.6483 – 0.6490)	16.45 (0.648)
Kickstarter idle gear I.D.			17.016 – 17.034 (0.6699 – 0.6706)	17.05 (0.671)
Countershaft O.D. at kickstarter idle gear			16.983 – 16.994 (0.6686 – 0.6691)	16.97 (0.668)

GENERAL INFORMATION

Unit: mm (in)

CRANKCASE/CRANKSHAFT/TRANSMISSION			STANDARD	SERVICE LIMIT
ITEM				
Crankshaft	Side clearance		0.4 – 0.8 (0.02 – 0.03)	0.9 (0.04)
	Radial clearance		0.010 – 0.022 (0.0004 – 0.0009)	0.032 (0.0013)
	Runout		—	0.05 (0.002)
Transmission	Gear I.D.	M4, M5	23.020 – 23.041 (0.9063 – 0.9071)	23.06 (0.908)
		C1	20.020 – 20.041 (0.7882 – 0.7890)	20.06 (0.790)
		C2, C3	25.020 – 25.041 (0.9850 – 0.9859)	25.06 (0.987)
	Bushing O.D.	M4, M5	22.979 – 23.000 (0.9047 – 0.9055)	22.95 (0.904)
		C1	19.979 – 20.000 (0.7866 – 0.7874)	19.95 (0.785)
		C2, C3	24.979 – 25.000 (0.9834 – 0.9843)	24.95 (0.982)
	Bushing I.D.	M5	20.000 – 20.021 (0.7874 – 0.7782)	20.04 (0.789)
		C1	17.000 – 17.018 (0.6693 – 0.6700)	17.03 (0.670)
		C2, C3	22.000 – 22.021 (0.8661 – 0.8670)	22.04 (0.868)
	Gear-to-bushing clearance	M4, C1, C2, C3	0.020 – 0.062 (0.0008 – 0.0024)	0.11 (0.004)
		M5	0.040 – 0.082 (0.0016 – 0.0032)	0.12 (0.005)
	Mainshaft O.D.	M5	19.959 – 19.980 (0.7858 – 0.7866)	19.94 (0.785)
	Countershaft O.D.	C1 bushing	16.983 – 16.994 (0.6686 – 0.6691)	16.97 (0.668)
		C2 bushing, C3 bushing	21.959 – 21.980 (0.8645 – 0.8654)	21.94 (0.864)
		Starter idle gear	16.983 – 16.994 (0.6686 – 0.6691)	16.97 (0.668)
Bushing-to-shaft clearance	M5, C2, C3	0.020 – 0.062 (0.0008 – 0.0024)	0.10 (0.004)	
	C1	0.006 – 0.035 (0.0002 – 0.0014)	0.06 (0.002)	
Shift fork, shaft	Fork claw thickness		4.93 – 5.00 (0.194 – 0.197)	4.8 (0.19)
	Shift fork I.D.		11.035 – 11.056 (0.4344 – 0.4353)	11.065 (0.4356)
	Fork shaft O.D.		10.983 – 10.994 (0.4324 – 0.4328)	10.973 (0.4320)

Unit: mm (in)

FRONT WHEEL/SUSPENSION/STEERING			STANDARD	SERVICE LIMIT
ITEM				
Cold tire pressure			100 kPa (1.0 kgf/cm ² , 14 psi)	—
Axle runout			—	0.20 (0.008)
Wheel rim runout	Radial		—	2.0 (0.08)
	Axial		—	2.0 (0.08)
Wheel hub-to-rim distance			27.25 (1.073)	—
Fork	Spring free length	2000:	470.0 (18.50)	467 (18.4)
		After 2000:	483.0 (19.02)	480 (18.9)
	Tube runout		—	0.2 (0.01)
	Recommended fork fluid		Pro-Honda HP Fork Oil 5W or equivalent	
	Fluid level	2000:	60 (2.4)	—
		2001:	59 (2.3)	—
		After 2001:	98 (3.9)	—
	Fluid capacity	2000:	518 cm ³ (17.5 US oz, 18.2 Imp oz)	—
		2001:	502 cm ³ (17.0 US oz, 17.7 Imp oz)	—
		After 2001:	475 cm ³ (16.1 US oz, 16.7 Imp oz)	—
Compression damping adjuster standard position		2000:	11 clicks out from full in	—
		2001:	9 clicks out from full in	—
		After 2001:	8 clicks out from full in	—
Rebound damping adjuster standard position		2000 – 2001:	9 clicks out from full in	—
		After 2001:	12 clicks out from full in	—

GENERAL INFORMATION

Unit: mm (in)

REAR WHEEL/SUSPENSION			STANDARD	SERVICE LIMIT
ITEM				
Cold tire pressure			100 kPa (1.0 kgf/cm ² , 14 psi)	—
Axle runout			—	0.20 (0.008)
Wheel rim runout	Radial		—	2.0 (0.08)
	Axial		—	2.0 (0.08)
Wheel hub-to-rim distance			51.00 (2.008)	—
Drive chain slack			25 – 35 (1 – 1-3/8)	—
Drive chain size/link	DID	2000:	520DM – 116	—
		2001:	520DMA2 – 116	—
		After 2001:	520DMA2 – 114	—
	RK	2000:	520KZ6 – 116	—
Drive chain slider thickness			—	5 (0.2)
Drive chain tensioner roller O.D.			—	25 (1.0)
Shock absorber	Damper gas pressure		981 kPa (10.0kg/cm ² , 142 psi)	—
	Damper compressed gas		Nitrogen gas	—
	Damper rod compressed force at 10 mm compressed		18.1 – 22.1 kg (39.90 – 48.72 lbf)	—
	Spring direction		Narrow wound end of coil facing down	—
	Spring installed length (standard)	2000:	265 (10.4)	—
After 2000:		267 (10.5)	—	
High speed side compression damping adjuster standard position	2000 – 2001:	10/12 – 1-2/10 turns out from full in	—	
	After 2001:	1-1/6 – 1-1/2 turns out from full in	—	
Low speed side compression damping adjuster standard position	2000:	9 – 12 clicks out from full in	—	
	2001:	8 – 11 clicks out from full in	—	
	After 2001:	11 – 14 clicks out from full in	—	
Rebound damping adjuster standard position	2000 – 2001:	22 – 26 clicks out from full in	—	
	After 2001:	18 – 22 clicks out from full in	—	

Unit: mm (in)

HYDRAULIC BRAKE		STANDARD	SERVICE LIMIT
ITEM			
Front	Specified brake fluid	DOT 4	—
	Brake pad wear indicator	—	1.0 (0.04)
	Brake disc thickness	3.0 (0.12)	2.5 (0.10)
	Brake disc runout	—	0.15 (0.006)
	Master cylinder I.D.	11.000 – 11.043 (0.4330 – 0.4347)	11.05 (0.435)
	Master piston O.D.	10.957 – 10.984 (0.4314 – 0.4324)	10.84 (0.427)
	Caliper cylinder I.D.	27.000 – 27.050 (1.0630 – 1.0650)	27.06 (1.065)
	Caliper piston O.D.	2000: 26.900 – 26.950 (1.0590 – 1.0610) After 2000: 26.861 – 26.894 (1.0575 – 1.0588)	26.89 (1.059) 26.85 (1.057)
Rear	Specified brake fluid	DOT4	—
	Brake pad wear indicator	—	1.0 (0.04)
	Brake disc thickness	4.0 (0.16)	3.5 (0.14)
	Brake disc runout	—	0.15 (0.006)
	Master cylinder I.D.	2000 – 2001: 12.700 – 12.743 (0.4999 – 0.5016)	12.76 (0.502)
		After 2001: 9.520 – 9.563 (0.3748 – 0.3765)	9.575 (0.3770)
	Master piston O.D.	2000 – 2001: 12.657 – 12.684 (0.4983 – 0.4993)	12.64 (0.498)
		After 2001: 9.477 – 9.504 (0.3731 – 0.3742)	9.465 (0.3726)
	Caliper cylinder I.D.	2000 – 2001: 27.000 – 27.050 (1.0630 – 1.0650)	27.06 (1.065)
		After 2001: 22.650 – 22.700 (0.8917 – 0.8937)	22.712 (0.8942)
Caliper piston O.D.	2000 – 2001: 26.935 – 26.968 (1.0604 – 1.0617)	26.89 (1.059)	
	After 2001: 22.585 – 22.618 (0.8892 – 0.8905)	22.573 (0.8887)	

GENERAL INFORMATION

IGNITION SYSTEM			
ITEM		SPECIFICATIONS	
Spark plug	Standard (NGK)		BR9EG
	Standard (DENSO)		W27ESR-V
	Optional (NGK)		BR9EV
	Optional (DENSO)		W27ESR-G
Spark plug gap			0.5 – 0.6 mm (0.020 – 0.024 in)
Ignition coil resistance (at 20°C/68°F)	Primary	2000 – 2001:	0.1 – 0.3 Ω
		After 2001:	0.4 – 0.6 Ω
	Secondary with plug cap	2000 – 2001:	9 – 16 kΩ
		After 2001:	15 – 22 kΩ
	Secondary without plug cap	2000 – 2001:	4 – 8 kΩ
		After 2001:	10 – 17 kΩ
Ignition coil peak voltage			100 V minimum
Ignition pulse generator resistance (at 20°C/68°F)			180 – 280 Ω
Ignition pulse generator peak voltage			0.7 V minimum
Alternator exciter coil resistance (at 20°C/68°F)	2000 – 2001:		9 – 25 Ω
	After 2001:		Yellow – Blue: 120 – 180 Ω Blue – White: 24 – 44 Ω
Alternator exciter coil peak voltage	2000 – 2001:		100 V minimum
	After 2001:		20 V minimum (Yellow – Blue and Blue – White)
Ignition timing ("F" mark)	2000 – 2001:		31 ± 2° BTDC at 3,000 rpm
	After 2001:		35 ± 2° BTDC at 3,000 rpm

TORQUE VALUES

FASTENER TYPE	TORQUE N·m (kgf·m, lbf·ft)	FASTENER TYPE	TORQUE N·m (kgf·m, lbf·ft)
5 mm hex bolt and nut	5 (0.5, 3.6)	5 mm screw	4 (0.4, 2.9)
6 mm hex bolt and nut	10 (1.0, 7)	6 mm screw	9 (0.9, 6.5)
8 mm hex bolt and nut	22 (2.2, 16)	6 mm flange bolt (8 mm head)	9 (0.9, 6.5)
10 mm hex bolt and nut	34 (3.5, 25)	6 mm flange bolt (10 mm head) and nut	12 (1.2, 9)
12 mm hex bolt and nut	54 (5.5, 40)	8 mm flange bolt and nut	26 (2.7, 20)
		10 mm flange bolt and nut	39 (4.0, 29)

- Torque specifications listed below are for important fasteners.
- Others should be tightened to standard torque values listed above.

- NOTES: 1. Apply a locking agent to the threads.
 2. Apply oil to the threads and flange surface.
 3. Stake.
 4. U-nut.
 5. UBS bolt/nut.

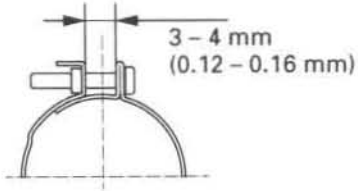
ENGINE				
ITEM	Q'TY	THREAD DIA. (mm)	TORQUE N·m (kgf·m, lbf·ft)	REMARKS
MAINTENANCE:				
Oil drain bolt	1	12	29 (3.0, 22)	
Spark plug	1	14	18 (1.8, 13)	
Oil check bolt (Right crankcase side)	1	6	10 (1.0, 7)	
FUEL SYSTEM:				
Reed valve mounting screw	6	3	1 (0.1, 0.7)	NOTE 1
Throttle cable holder	1	10	3 (0.3, 2.2)	
Float pin set screw	1	4	2 (0.2, 1.4)	
Needle jet holder (2000 – 2001:)	1	8	3 (0.3, 2.2)	
Main jet	1	5.3	2 (0.2, 1.4)	
Slow jet	1	4	1 (0.1, 0.7)	
Carburetor top screw (2000:)	2	4	4 (0.4, 3.0)	
(After 2000:)	2	4	2 (0.2, 1.4)	
Throttle stop screw lock nut	1	5	2 (0.2, 1.4)	
Float chamber screw (2000 – 2001:)	1	4	2 (0.2, 1.4)	
(After 2001:)	3	4	4 (0.4, 3.0)	
Carburetor drain plug (2000 – 2001:)	1	12	7 (0.7, 5.1)	
(After 2001:)	1	22	4 (0.4, 3.0)	
Choke valve	1	–	4 (0.4, 3.0)	
Float valve seat set screw	1	3	1 (0.1, 0.7)	
Insulator band screw				
				
COOLING SYSTEM:				
Water pump impeller	1	7	12 (1.2, 9)	NOTE 1
Water pump cover bolt	2	6	12 (1.2, 9)	
Coolant drain bolt	1	6	10 (1.0, 7)	
CYLINDER HEAD/CYLINDER/PISTON:				
Cylinder stud bolt	5	8	12 (1.2, 9)	NOTE 1
Cylinder head nut	5	8	27 (2.8, 20)	
Cylinder mounting nut	4	8	27 (2.8, 20)	
Exhaust pipe joint bolt	3	6	12 (1.2, 9)	
Cylinder sealing bolt	1	6	10 (1.0, 7)	
RC VALVE:				
Flap valve shaft nut	1	6	9 (0.9, 6.5)	NOTE 1
RC valve cover bolt	4	6	12 (1.2, 9)	
RC valve cover screw	1	5	3 (0.3, 2.2)	
Blow-by oil drain bolt	1	6	10 (1.0, 7)	
RC valve pinion rod setting screw	1	6	9 (0.9, 6.5)	

GENERAL INFORMATION

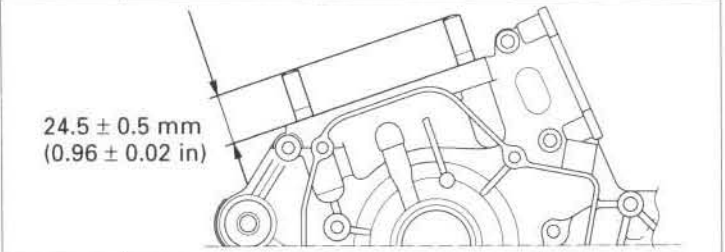
ENGINE (Cont'd)				
ITEM	Q'TY	THREAD DIA. (mm)	TORQUE N-m (kgf-m, lbf-ft)	REMARKS
CLUTCH/KICKSTARTER/GEARSHIFT LINKAGE :				
Gearshift drum center pin	1	8	22 (2.2, 16)	NOTE 1
Gearshift drum stopper arm bolt	1	6	12 (1.2, 9)	
Clutch center lock nut	1	18	69 (7.0, 51)	
Clutch spring bolt	6	6	10 (1.0, 7)	
Gearshift pedal pinch bolt	1	6	12 (1.2, 9)	
Kickstarter pedal bolt	1	8	37 (3.8, 27)	
CRANKCASE/CRANKSHAFT/TRANSMISSION:				
Primary drive gear bolt	1	10	64 (6.5, 47)	NOTE 1 NOTE 1 NOTE 5
Countershaft bearing set plate bolt	2	6	10 (1.0, 7)	
Gearshift drum bearing set plate screw	2	6	10 (1.0, 7)	
Drive sprocket bolt	1	8	26 (2.7, 20)	
Crankcase stud bolt				
 <p>24.5 ± 0.5 mm (0.96 ± 0.02 in)</p>				
ALTERNATOR:				
Flywheel nut	1	12	54 (5.5, 40)	
Alternator cover screw (2000:)	4	6	2 (0.2, 1.4)	

FRAME					
ITEM	Q'TY	THREAD DIA. (mm)	TORQUE N-m (kgf-m, lbf-ft)	REMARKS	
FRAME/BODY PANELS/EXHAUST SYSTEM:					
Seat mounting bolt	2	8	26 (2.7, 20)		
Sub-frame mounting bolt (upper)	1	8	29 (3.0, 22)		
Seat bracket screw	1	5	6 (0.6, 4.3)		
Front chamber stay bolt	2	6	12 (1.2, 9)		
Footpeg bracket bolt (upper)	1	12	54 (5.5, 40)		
(lower)	1	10	42 (4.3, 31)		
MAINTENANCE:					
Drive chain adjusting bolt lock nut	2	8	26 (2.7, 20)		NOTE 5
ENGINE MOUNTING:					
Engine hanger plate nut	3	8	34 (3.5, 25)		
Engine mounting nut	2	10	54 (5.5, 40)		
Front brake hose guide bolt	1	6	5 (0.5, 3.6)		
FRONT WHEEL/SUSPENSION/STEERING:					
Front axle nut	1	16	88 (9.0, 65)	NOTE 4	
Front axle holder bolt	4	8	20 (2.0, 14)		
Front spoke nipple	36	BC 3.5	4 (0.4, 3.0)		
Front rim lock	1	8	13 (1.3, 9)		
Front brake disc nut	6	6	16 (1.6, 12)		
Steering stem nut (2000:)	1	26	147 (15.0, 108)		
(After 2000:)	1	26	108 (11.0, 80)		
Steering stem adjust nut	1	30	7 (0.7, 5.1)		
Fork tube pinch bolt (top)	4	8	22 (2.2, 16)		
(bottom)	4	8	20 (2.0, 14)		
Fork cap	2	48	29 (3.0, 22)	NOTE 1 NOTE 1	
Fork cap lock nut	2	12	28 (2.9, 21)		
Fork center bolt	2	30	54 (5.5, 40)		
Fork protector mounting bolt	6	6	7 (0.7, 5.1)		
Front brake disc cover bolt	2	6	13 (1.3, 9)		
Fork air pressure release screw	2	5	1.2 (0.12, 0.87)		
Handlebar upper holder bolt	4	8	22 (2.2, 16)		
Clutch lever pivot bolt	1	6	2 (0.2, 1.4)		

FRAME (Cont'd)				
ITEM	Q'TY	THREAD DIA. (mm)	TORQUE N-m (kgf-m, lbf-ft)	REMARKS
Clutch lever pivot nut	1	6	10 (1.0, 7)	
Clutch lever holder bolt	2	6	9 (0.9, 6.5)	
Throttle housing bolt	2	6	9 (0.9, 6.5)	
Throttle housing cover screw	1	4	2 (0.2, 1.4)	
Engine stop button screw	1	4	2 (0.2, 1.4)	
REAR WHEEL/SUSPENSION:				
Rear axle nut	1	22	127 (13.0, 94)	NOTE 4
Rear spoke nipple		4.5	4 (0.4, 3.0)	
Rear rim lock	1	8	13 (1.3, 9)	
Rear brake disc bolt (2000 – 2001:)	4	8	42 (4.3, 31)	NOTE 1
Rear brake disc bolt/nut (After 2001:)	4	6	16 (1.6, 12)	
Final driven sprocket nut	6	8	32 (3.3, 24)	NOTE 4
Rear wheel bearing retainer	1	50	44 (4.5, 33)	
Swingarm pivot nut	1	14	88 (9.0, 65)	NOTE 4
Shock arm (swingarm side)	1	12	78 (8.0, 58)	NOTE 4
(shock link side)	1	12	78 (8.0, 58)	NOTE 4
Shock link (frame side)	1	12	78 (8.0, 58)	NOTE 4
Shock absorber mounting nut	2	10	44 (4.5, 33)	NOTE 4
Shock absorber spring lock nut	1	56	29 (3.0, 22)	
Drive chain roller bolt (2000:)	1	8	22 (2.2, 16)	
(After 2000:)	1	8	12 (1.2, 9)	
Drive chain guide mounting nut	2	6	12 (1.2, 9)	NOTE 4
Drive chain slider screw	2	5	4 (0.4, 3.0)	NOTE 1
Rear brake hose guide screw (2000 – 2001:)	4	5	12 (0.12, 0.87)	
(After 2001:)	2	5	1.2 (0.12, 0.87)	
Shock absorber damper rod end nut	1	12	26 (2.7, 20)	NOTE 3
Shock absorber damping adjuster	1	28	29 (3.0, 22)	NOTE 3
HYDRAULIC BRAKE:				
Brake hose oil bolt	4	10	34 (3.5, 25)	
Brake lever pivot bolt/nut	1/1	6/6	6 (0.6, 4.3)	
Brake lever adjuster lock nut	1	5	6 (0.6, 4.3)	
Front master cylinder reservoir cover screw	2	4	1 (0.1, 0.7)	
Rear master cylinder reservoir cover bolt (After 2001:)	2	4	1 (0.1, 0.7)	
Front master cylinder holder bolt	2	6	10 (1.0, 7)	
Front caliper mounting bolt	2	8	30 (3.1, 22)	NOTE 1
Caliper bleed valve	2	8	6 (0.6, 4.3)	
Rear brake disc guard mounting screw	2	6	7 (0.7, 5.1)	
Rear master cylinder mounting bolt	2	6	13 (1.3, 9)	
Front caliper pin bolt	2	8	23 (2.3, 17)	NOTE 1
Brake caliper pad pin	2	10	18 (1.8, 13)	
Brake caliper pad pin plug (2000 – 2001:)	2	10	2 (0.2, 1.4)	
(After 2001:)	1	10	2 (0.2, 1.4)	
Rear caliper pin bolt	1	12	27 (2.8, 20)	
Rear caliper bracket pin bolt	1	8	13 (1.3, 9)	NOTE 1
Brake pedal pivot bolt	1	8	26 (2.6, 19)	
Rear master cylinder joint nut (2000 – 2001:)	1	8	18 (1.8, 13)	
(After 2001:)	1	6	6 (0.6, 4.3)	

GENERAL INFORMATION

TOOLS

- NOTES: 1. Equivalent commercially available in U.S.A.
 2. Not available in U.S.A.
 3. Alternative tool.
 4. Newly designed tool.

DESCRIPTION	TOOL NUMBER	REMARKS	REF. SEC.
Analog tester	07308 - 0020001 (SANWA)		14
Carburetor float level gauge	07401 - 0010000		4
Universal bearing puller	07631 - 0010000	NOTE 1	10
Spoke wrench, 5.8 x 6.1 mm	07701 - 0020300	NOTE 1	3, 11
Spoke wrench, 6.5 mm (2000 - 2001:)	07701 - 0020400	NOTE 1	3, 12
Spoke wrench, 6.6 mm (After 2001:)	070MA - KZ30100	NOTE 1	3, 12
Bearing retainer wrench body	07710 - 0010401		12
Lock nut wrench, 20 x 24 mm	07716 - 0020100		12
Gear holder	07724 - 0010200	NOTE 2	10
Clutch center holder	07724 - 0050002	NOTE 3: 07724 - 0050100 NOTE 1	9
Universal holder	07725 - 0030000		10, 14
Flywheel puller	07733 - 0010000	NOTE 3: 07933 - 0010000	14
Valve guide driver, 22 mm I. D.	07742 - 0020200		8
Attachment, 37 x 40 mm	07746 - 0010200		10, 11
Attachment, 42 x 47 mm	07746 - 0010300		10, 12
Attachment, 52 x 55 mm	07746 - 0010400		10
Attachment, 24 x 26 mm	07746 - 0010700		5, 12
Attachment, 30 mm I. D.	07746 - 0030300		11, 12
Pilot, 12 mm	07746 - 0040200		5
Pilot, 17 mm	07746 - 0040400		10, 12
Pilot, 20 mm	07746 - 0040500		10, 11, 12
Pilot, 25 mm	07746 - 0040600		10, 12
Pilot, 22 mm	07746 - 0041000		12
Pilot, 28 mm	07746 - 0041100		10
Pilot, 19 mm	07746 - 0041400	NOTE 4	12
Bearing remover shaft	07746 - 0050100		11, 12
Bearing remover head, 20 mm	07746 - 0050600		11
Bearing remover head, 25 mm	07746 - 0050800		12
Driver	07749 - 0010000		5, 10, 11, 12
Snap ring pliers	07914 - SA50001	NOTE 3: 07914 - 3230001	13
Steering stem socket	07916 - 3710101	NOTE 3: 07702 - 0020001	11
Bearing remover, 7 mm	07931 - KA30000	NOTE 2	5, 8
Bearing remover set, 12 mm	07936 - 1660101	NOTE 2	5
- remover weight	07741 - 0010201	NOTE 3: 07936 - 371020A or 07936 - 3710200	
- remover handle assembly	07936 - 1660101	NOTE 3: 07936 - 166010A (U.S.A. only)	
- remover head, 12 mm	07936 - 1660110	NOTE 2	
- remover shaft	07936 - 1660120	NOTE 2	
Bearing remover, 17 mm	07936 - 3710300		10
- remover weight	07741 - 0010201	NOTE 3: 07936 - 3710200	
- remover handle	07936 - 3710100		
Crankcase puller	07937 - 4300001	NOTE 3: 07937 - 4300000 or 07631 - 0010000 use with 6 x 100 mm bolts and large washers	10
Water seal driver	07945 - KA30000	NOTE 3: 07965 - 415000A (U.S.A. only) or GN - AH - 065 - 415	5
Attachment, 28 x 30 mm	07946 - 1870100		12
Ball race remover	07946 - 3710500	NOTE 3: 07949 - 3710001 and 07946 - 1870100	11
Bearing driver, 7 mm	07946 - KA30100	NOTE 2	5, 8
Spherical bearing driver	07946 - KA30200	NOTE 2	12
Driver handle	07949 - 3710001		12
Crankcase assembly tool set	07965 - 1660102	NOTE 2 NOTE 3: 07965 - 1660101 or 07965 - 1660100	10
-assembly tool shaft	07965 - 1660200		
-assembly collar	07965 - 1660302	NOTE 3: 07965 - 1660301 or 07965 - 1660300 or 07965 - 166030A (NOTE 2)	

GENERAL INFORMATION

DESCRIPTION	TOOL NUMBER	REMARKS	REF. SEC.
Threaded adapter	07965 - KA30000	NOTE 3: 07VMF - HM8010A	10
Assembly collar	07965 - VM00100		10
Threaded shaft	07965 - VM00200	NOTE 3: 07931 - ME4010B and 07931 - HB3020A (U.S.A. only)	10
Slider guide attachment		NOTE 2	12
Peak voltage adapter	07MAG - SP00102	NOTE 2	14
Slider guide, 16 mm	07HGJ - 0020100	NOTE 2	12
Fork rod holder handle	07PMG - KZ40100	NOTE 2	11
Fork seal driver, 46 mm	07TMB - 001010A 07TMD - MAC0100	NOTE 3: 07TMD - MAC010A (U.S.A. only)	12
Taper bearing installer	07VMF - KZ30100		11
Installer shaft	07VMF - KZ30200		11
Retainer wrench, $\varnothing 48 \times 15$	07YMA - KZ40100	NOTE 3 : 07HMA - KS70100 (U.S.A. only)	12
Fork rod holder attachment, 32 mm	07YMB - KZ40100		11
Pin spanner, 4 mm	89201 - KS6 - 810	2 piece NOTE 3 : 07702 - 0020001	12

GENERAL INFORMATION

LUBRICATION & SEAL POINTS

ENGINE	LOCATION	MATERIAL	REMARKS
	Connecting rod big end, small end and journal area Piston outer surface Piston pin outer surface Piston ring end gap and outer surface Right and left exhaust valve operation area	Pro-Honda HP2 2-Stroke Oil or equivalent	
	Crankshaft big end Exhaust valve cover inside each operation area Flap valve shaft rolling area and sliding surface Flap valve arm sliding surface Governor steel ball area Governor bearing rolling area (right crankcase cover side) Valve rod joint area Kickstarter spindle spline and pinion sliding surface Kickstarter bearing rolling area (right crankcase cover side) Mainshaft/countershaft spline and gear rolling area Gearshift spindle spline Gearshift drum guide groove Shift fork claw Shift fork shaft outer surface Right crankcase outside bearing area (water pump, governor, kickstarter)	Use molybdenum solution (mixture of the engine oil and molybdenum grease with the ratio 100 g : 70 cc)	
	Clutch lifter lever cam area	Molybdenum paste	
	Governor contact area Transmission gear teeth, rolling area and contact area Right and left crankshaft bearing rolling area Main and countershaft bearing rolling area Gearshift drum bearing rolling area Clutch outer needle bearing rolling area Clutch outer guide surface Clutch lifter needle bearing rolling area Bearing rolling area	Transmission oil	
	Clutch lifter piece steel ball contact area Countershaft collar inside and O-ring Oil seal lips Water seal lips Exhaust pipe joint O-ring and outer surface (:After 2000)	Multi-purpose grease	
	Cylinder stud bolt cylinder side threads Countershaft bearing set plate bolt screw thread Gearshift drum bearing set plate screw thread	Honda Anaerobic Thread Lock or equivalent	6.5 ± 1 mm (0.26 ± 0.04 in) from tip 6.5 ± 1 mm (0.26 ± 0.04 in) from tip

FRAME		
LOCATION	MATERIAL	REMARKS
Shock arm-to-swingarm side nut threads and seating surface Throttle pipe inside and cable sliding surface	Pro-Honda GN4 4-Stroke Oil or equivalent	
Steering head bearing rolling area and oil seal lips Wheel bearing dust seal lips Swingarm pivot needle bearing rolling area Swingarm pivot thrust bearing rolling area Swingarm pivot dust seal lips Shock arm needle bearing rolling area Shock arm spherical bearing rolling area Shock arm thrust washer surface Shock arm dust seal lips Rear shock absorber spherical bearing rolling area Rear shock absorber dust seal lips Throttle cable roller inner and outer surface Kickstarter pedal joint shaft sliding surface Brake pedal pivot shaft sliding surface Gearshift pedal pin sliding surface	Multi-purpose grease	Apply 3 g Apply 3 g Apply two points
Brake caliper pin bolt/pin bolt A Brake lever pivot bolt sliding surface Brake lever adjust bolt tip Rear master cylinder push rod rounded surface Rear master cylinder boot setting area	Silicone grease	
Rear brake disc bolt threads Drive chain slider mounting screw threads Front brake caliper mounting bolt threads Brake caliper slide pin threads Rear disc cover mounting bolt threads Brake lever adjust bolt threads Front fork protector bolt threads Front disc cover bolt threads	Honda Anaerobic Thread Lock or equivalent	
Brake caliper piston seal lips Master cylinder inner surface Master piston outer sliding surface	DOT4 brake fluid	
Handle grip rubber inner surface	Honda Bond A or Honda Hand Grip Cement (U.S.A. only)	

CABLE & HARNESS ROUTING

2000 - 2001:

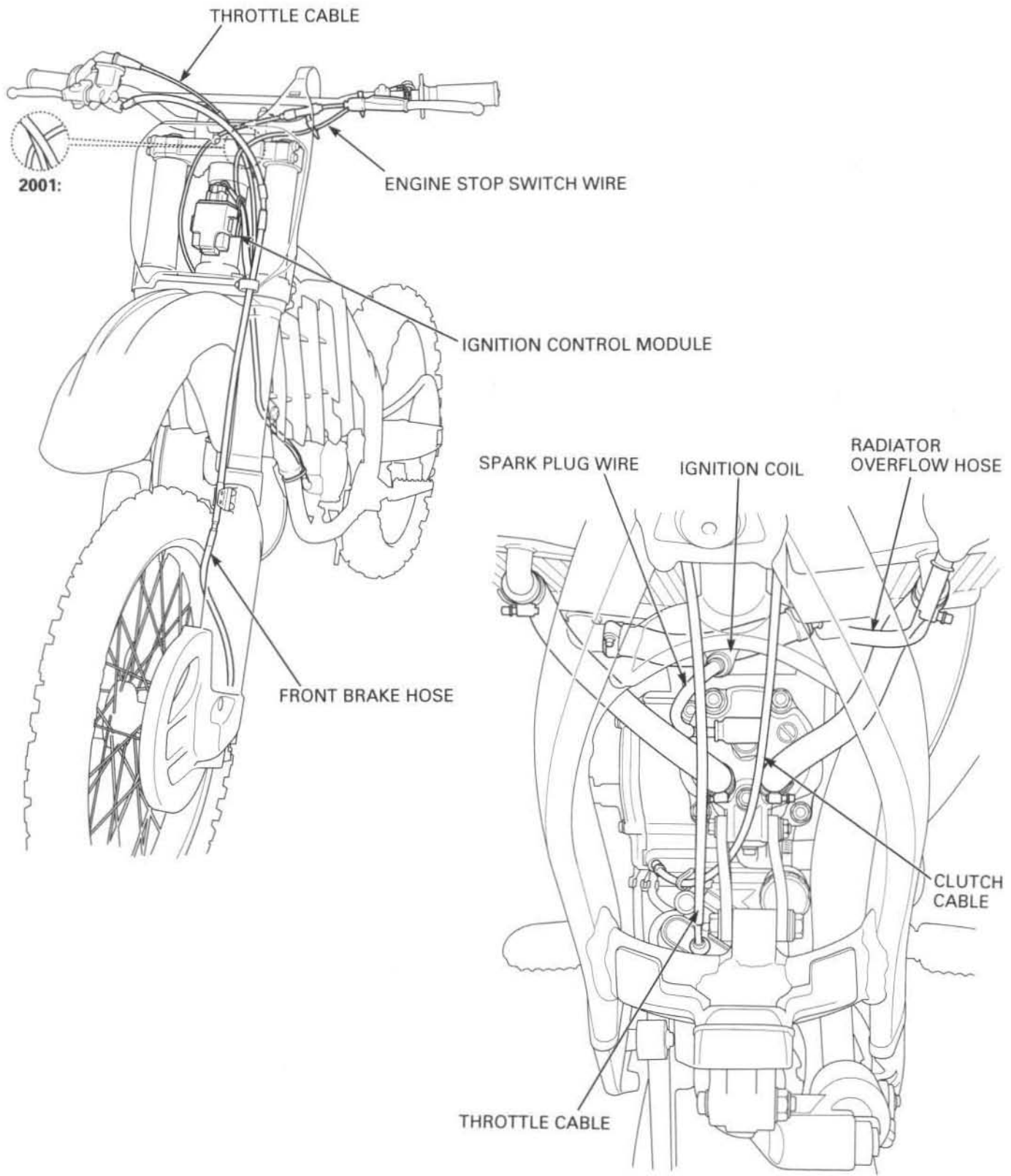

After 2001:

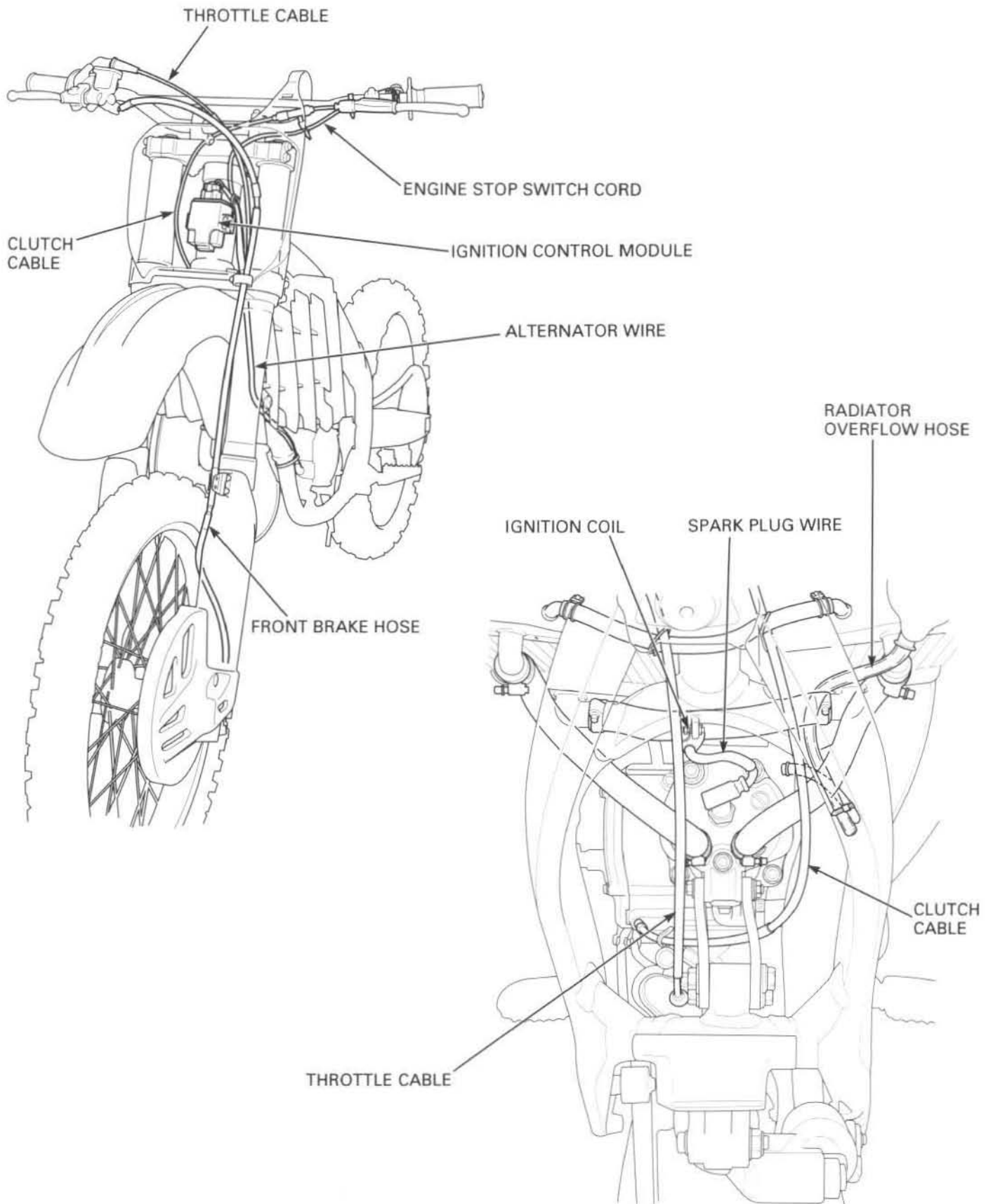

GENERAL INFORMATION

2000 - 2001:

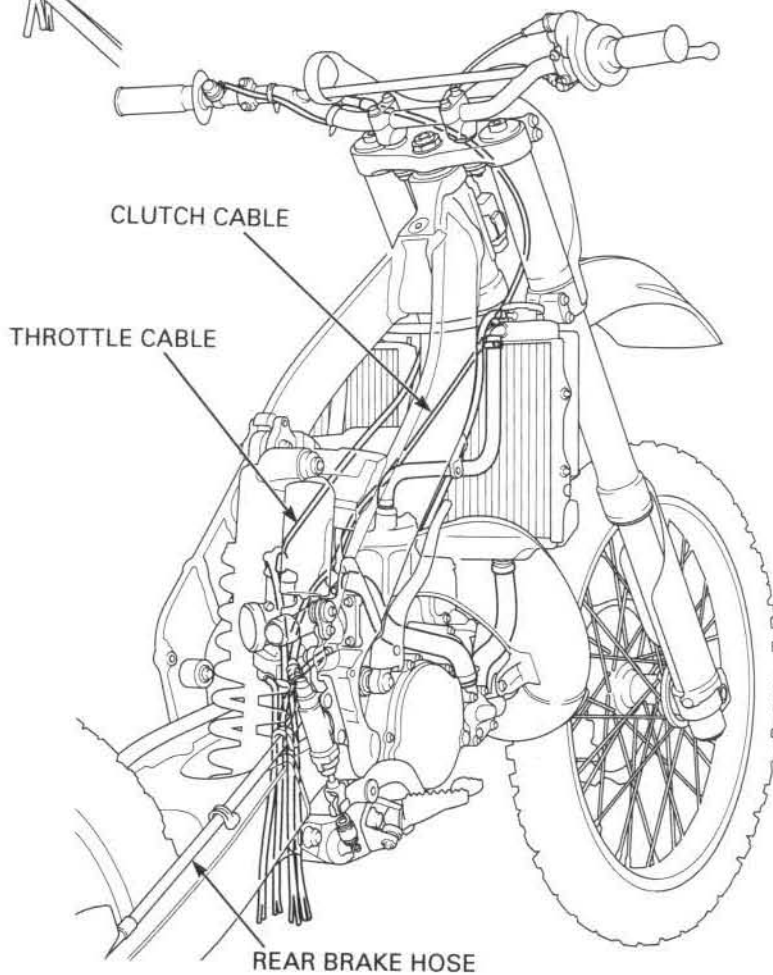
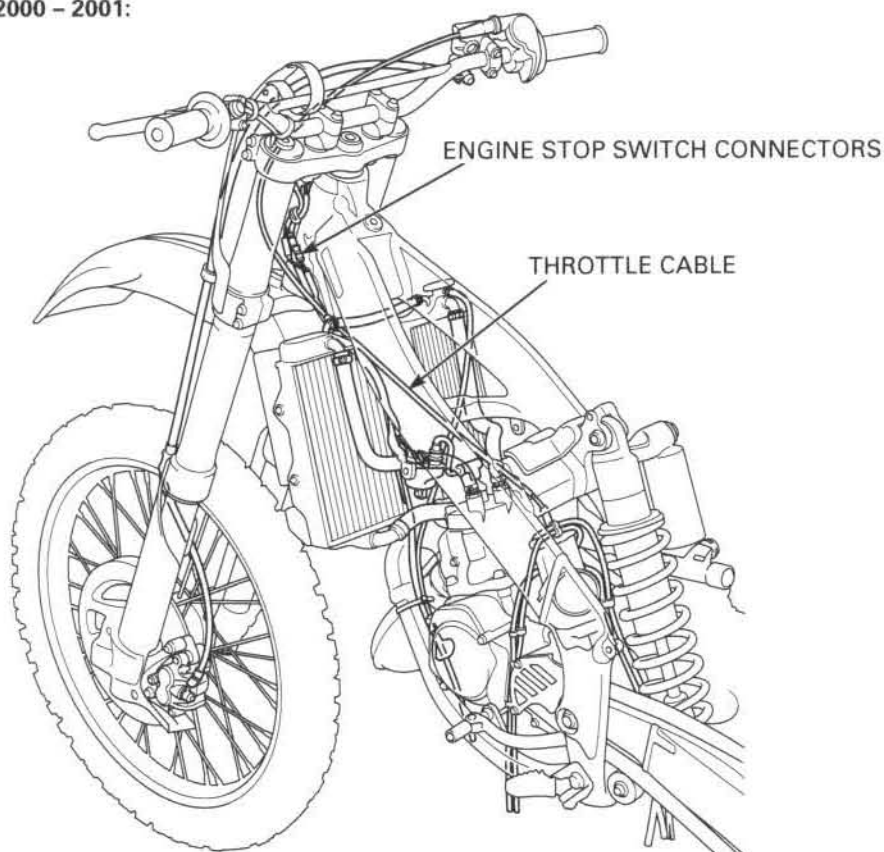

After 2001:

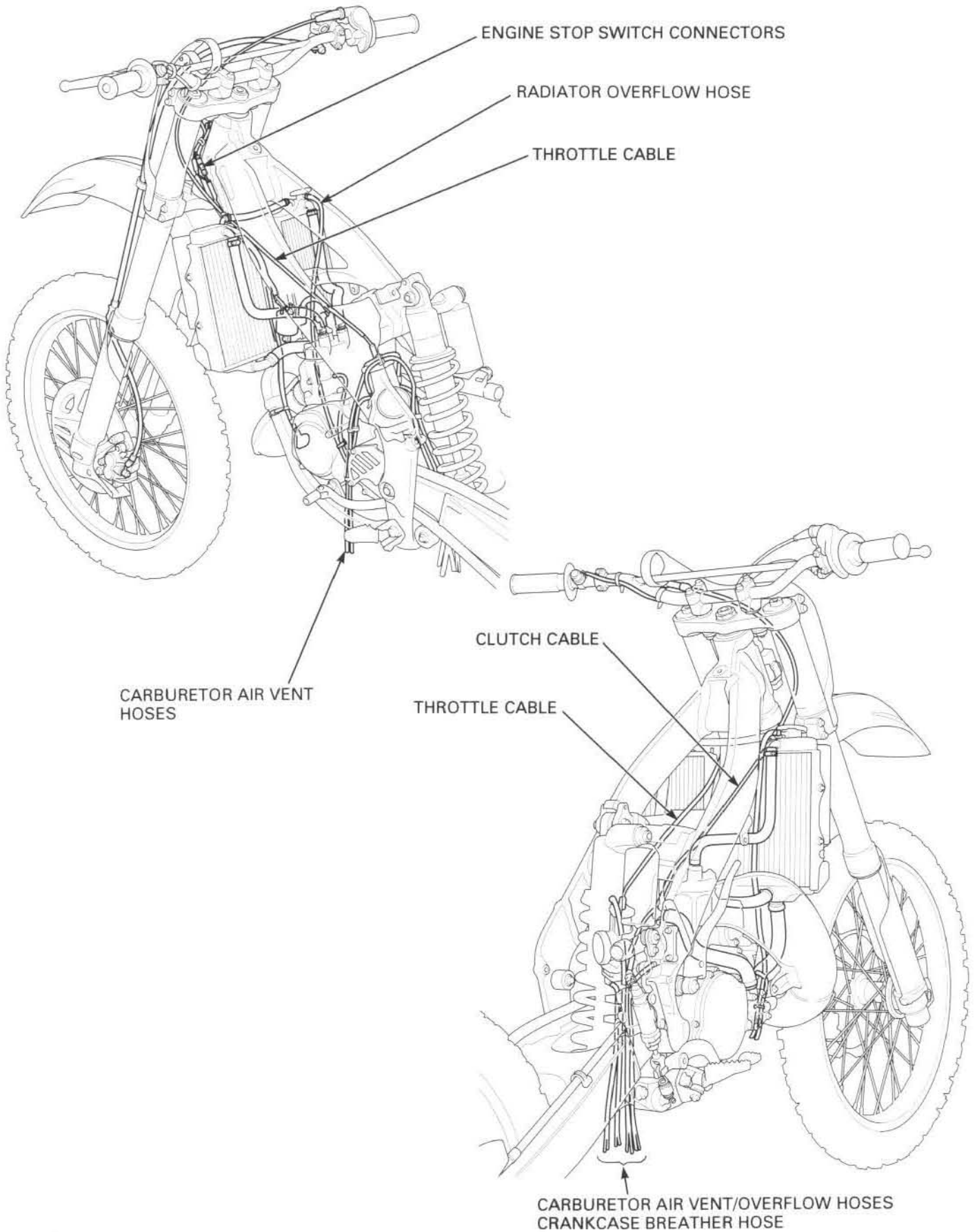

GENERAL INFORMATION

2000 - 2001:

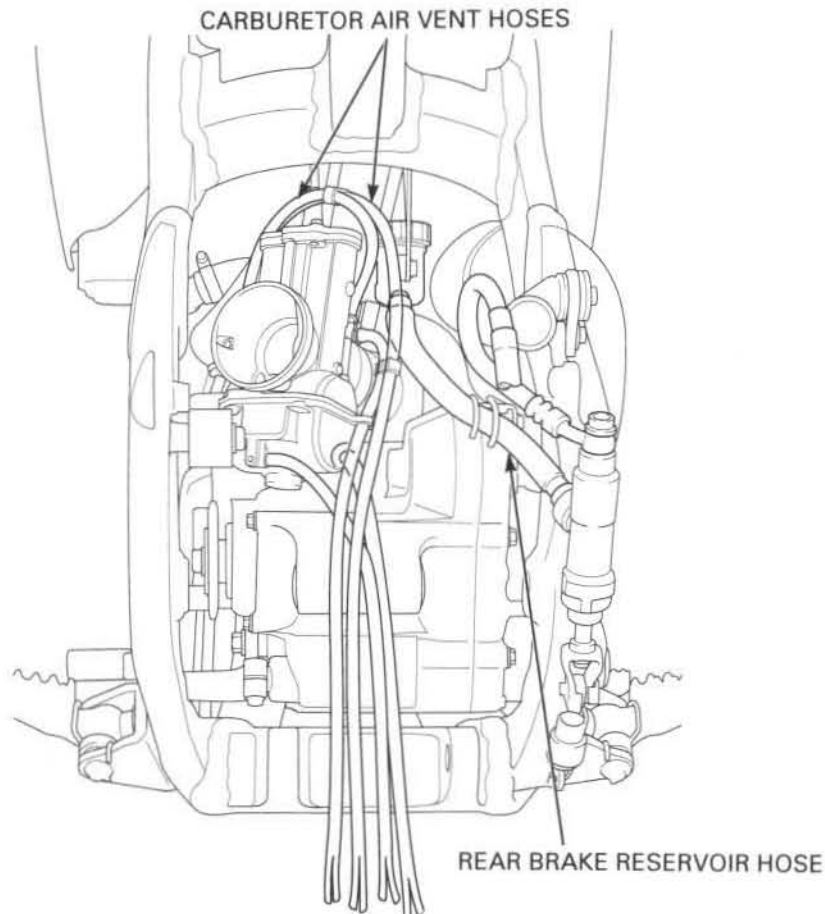
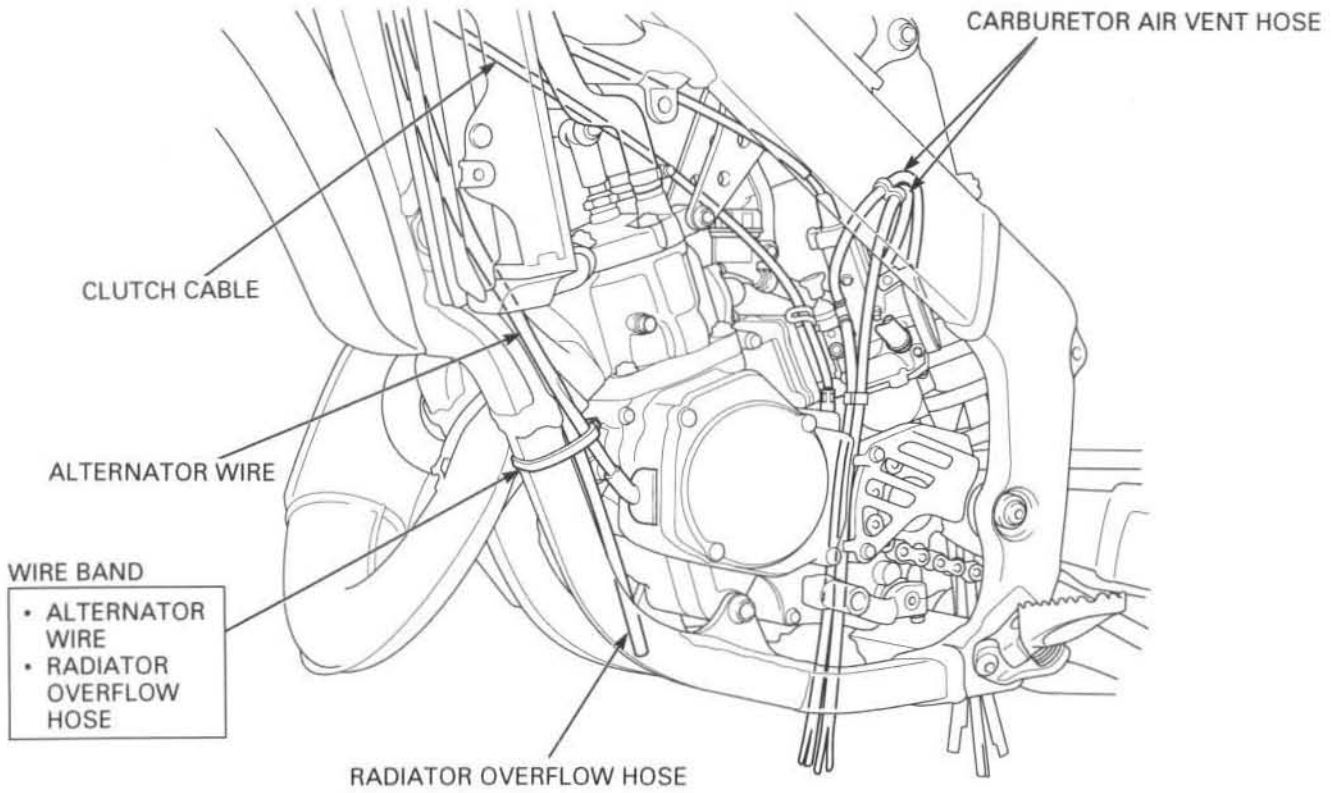

After 2001:

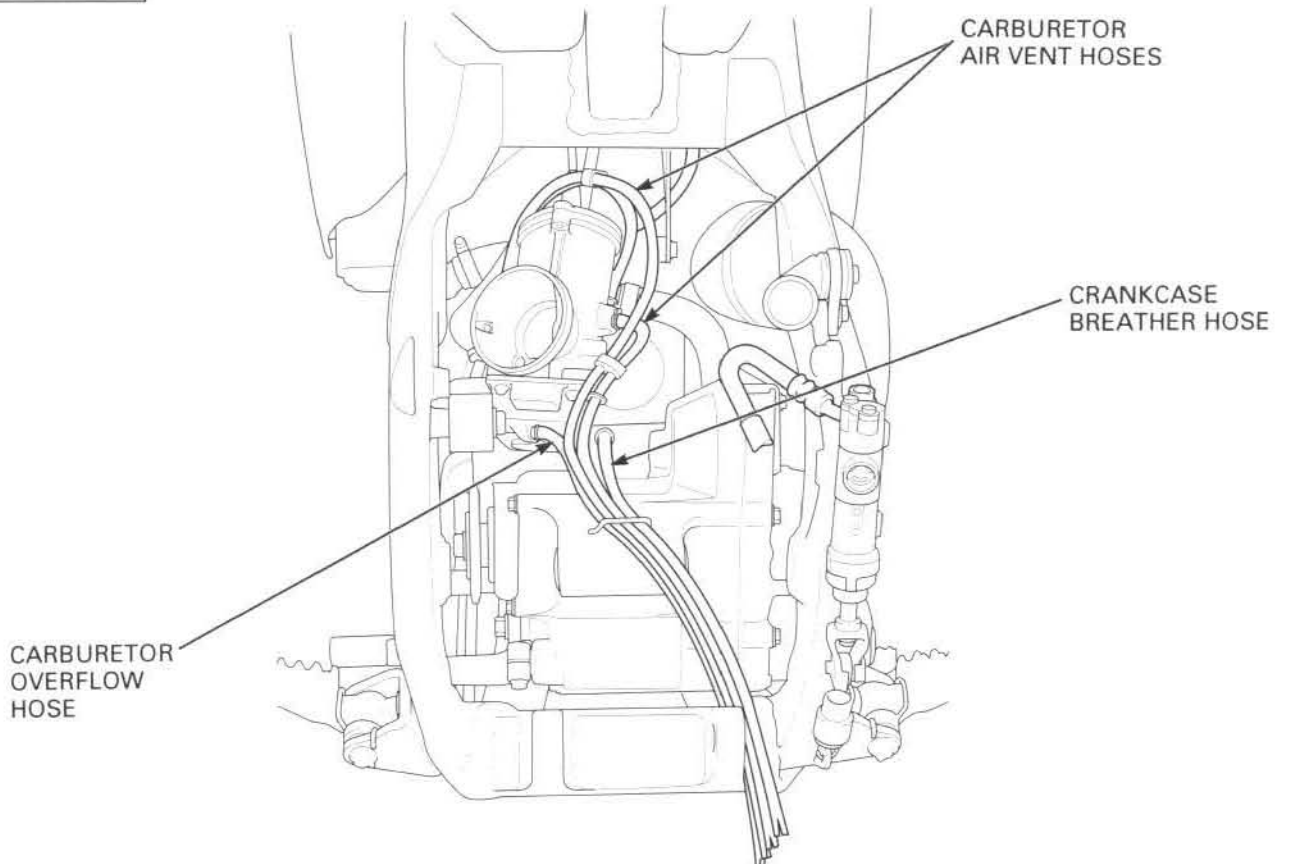
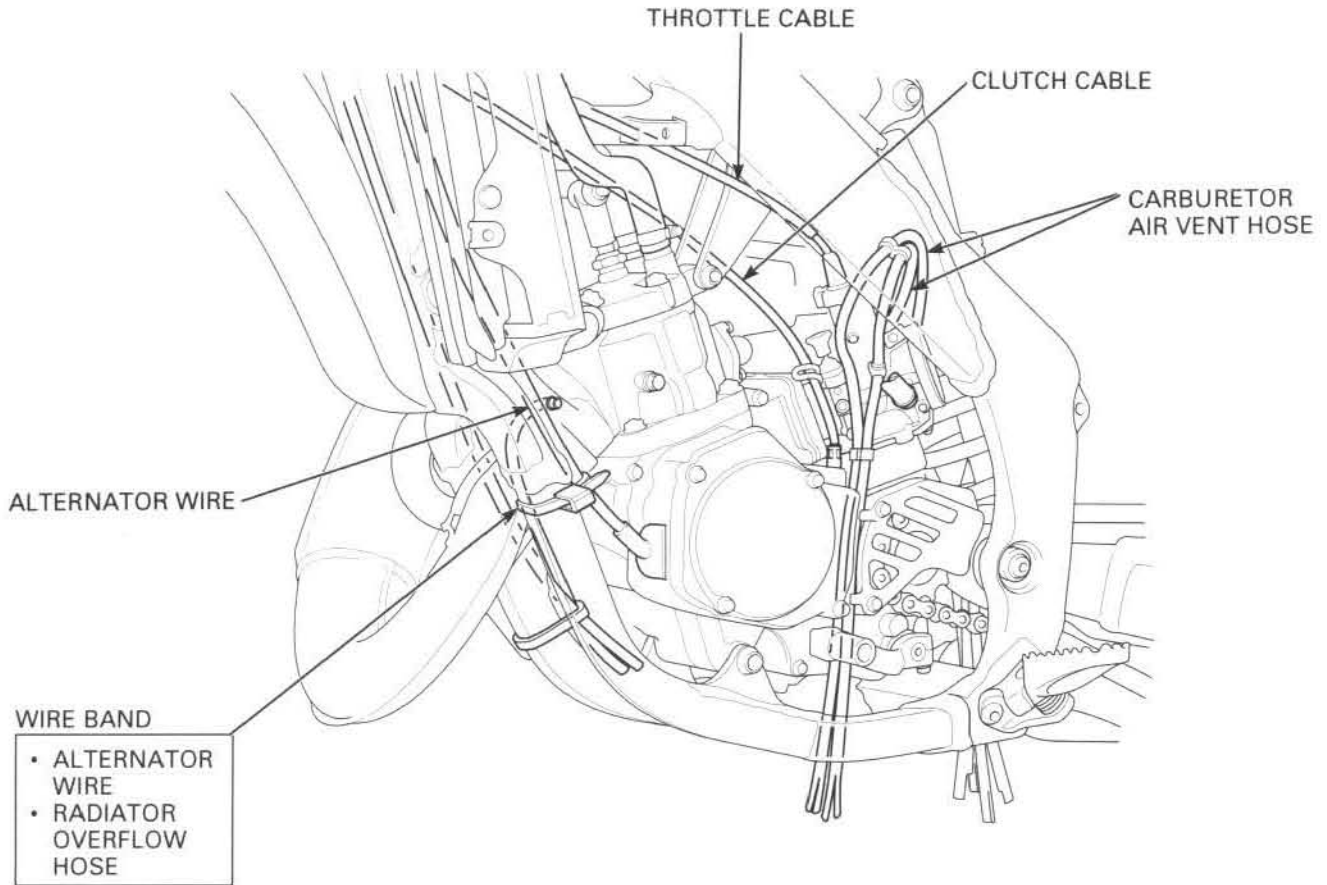

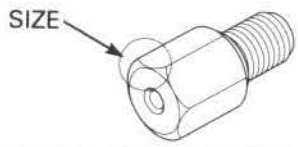
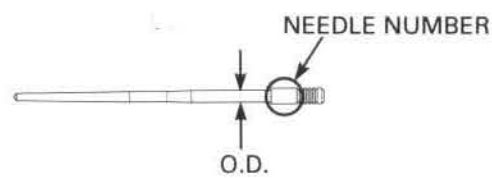

OPTIONAL PARTS

ENGINE		STANDARD		
CARBURETOR (2000):				
Main jet	Standard Optional	# 360 # 300 – 420 (increments of 10)		
Jet needle	Standard	6BEG20-69 (ø2.690)		
	General Flow Characteristics	Jet needle number	O.D. (mm)	Specific flow characteristics
	Leaner than the 6BEG20-71 needle	6BEG20-72	2.720	Leaner only at 1/16 to 1/4 throttle
	Leaner than the 6BEG20-70 needle	6BEG20-71	2.710	Leaner only at 1/16 to 1/4 throttle
	Leaner than the standard 6BEG20-69 needle	6BEG20-70	2.700	Leaner only at 1/16 to 1/4 throttle
	Richer than the standard 6BEG20-69 needle	6BEG20-68	2.680	Richer only at 1/16 to 1/4 throttle
	Richer than the 6BEG20-68 needle	6BEG20-67	2.670	Richer only at 1/16 to 1/4 throttle
	Richer than the 6BEG20-67 needle	6BEG20-66	2.660	Richer only at 1/16 to 1/4 throttle
	Richer than the 6BEG20-72 needle at 1/2 groove of the clip	6BEG21-72	2.720	Richer only at 1/8 to 3/4 throttle
	Richer than the 6BEG20-71 needle at 1/2 groove of the clip	6BEG21-71	2.710	Richer only at 1/8 to 3/4 throttle
	Richer than the 6BEG20-70 needle at 1/2 groove of the clip	6BEG21-70	2.700	Richer only at 1/8 to 3/4 throttle
	Richer than the standard 6BEG20-69 needle at 1/2 groove of the clip	6BEG21-69	2.690	Richer only at 1/8 to 3/4 throttle
	Richer than the 6BEG20-68 needle at 1/2 groove of the clip	6BEG21-68	2.680	Richer only at 1/8 to 3/4 throttle
	Richer than the 6BEG20-67 needle at 1/2 groove of the clip	6BEG21-67	2.670	Richer only at 1/8 to 3/4 throttle
	Richer than the 6BEG20-66 needle at 1/2 groove of the clip	6BEG21-66	2.660	Richer only at 1/8 to 3/4 throttle
				
	Jet needle clip standard position	3rd groove		
Slow jet	Standard Optional	# 50 # 45 - 55 (increments of 5)		

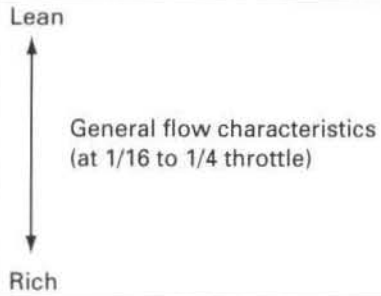
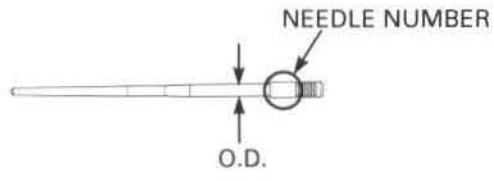
ENGINE

ITEM		REMARKS	
CARBURETOR (2001):			
Main jet	Standard Optional	#380 #300 – 450 (increments of 10)	
Jet needle	Standard	6BEG20 – 68 (ø2.680)	
	Specific flow characteristics at 1/6 to 1/4 throttle	Jet needle number (Standard series)	Jet needle number (1/2 clip position lower than standard series Richer only at 1/8 to 3/4 throttle)
	Lean  Rich	6BEG20-71 (ø2.710 mm)	6BEG21-71 (ø2.710 mm)
		6BEG20-70 (ø2.700 mm)	6BEG21-70 (ø2.700 mm)
		6BEG20-69 (ø2.690 mm)	6BEG21-69 (ø2.690 mm)
		6BEG20-68 (ø2.680 mm) (Standard needle)	6BEG21-68 (ø2.680 mm)
		6BEG20-67 (ø2.670 mm)	6BEG21-67 (ø2.670 mm)
		6BEG20-66 (ø2.660 mm)	6BEG21-66 (ø2.660 mm)
		6BEG20-65 (ø2.650 mm)	6BEG21-65 (ø2.650 mm)
			Explanation of the jet needle numbers (Example) 
Jet needle clip standard position		3rd groove	
Slow jet	Standard Optional	#45 #35 – 55 (increments of 5)	

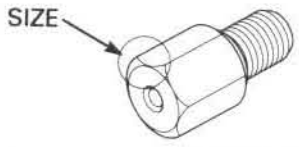

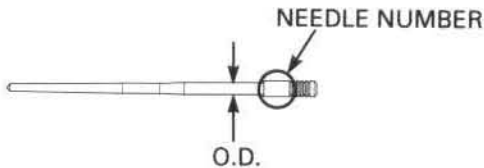

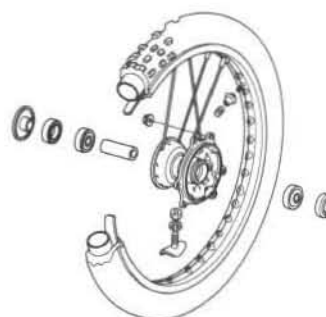
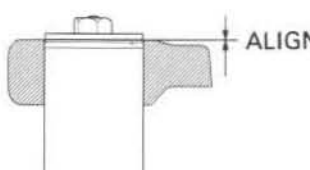



GENERAL INFORMATION

ENGINE		REMARKS	
CARBURETOR (After 2001):			
Main jet	Standard Optional	#400 #340 – 460 (increments of 10)	
Jet needle	Standard	6DFY5 – 74 (ø2.740)	
	Specific flow characteristics at 1/6 to 1/4 throttle	Jet needle number (Standard series)	Jet needle number (1/2 clip position lower than standard series Richer only at 1/8 to 3/4 throttle)
Rich  Lean	General flow characteristics (at 1/16 to 1/4 throttle)	6DFY5-71 (ø2.710 mm)	6DFY6-71 (ø2.710 mm)
		6DFY5-72 (ø2.720 mm)	6DFY6-72 (ø2.720 mm)
		6DFY5-73 (ø2.730 mm)	6DFY6-73 (ø2.730 mm)
		6DFY5-74 (ø2.740 mm) (STANDARD)	6DFY6-74 (ø2.740 mm)
		6DFY5-75 (ø2.750 mm)	6DFY6-75 (ø2.750 mm)
		6DFY5-76 (ø2.760 mm)	6DFY6-76 (ø2.760 mm)
		6DFY5-77 (ø2.770 mm)	6DFY6-77 (ø2.770 mm)
		Explanation of the jet needle numbers (Example) 	
Jet needle clip standard position		3rd groove	
Slow jet	Standard Optional	#32.5 #27.5 – 50 (under #40: increments of 2.5, over #40: increments of 5)	

FRAME	ITEM	REMARKS
<p>MAINTENANCE: Work stand Air pressure gauge (: 2000) Pin spanner</p>		<p>For maintenance For checking tire air pressure Pin spanner A X 2 For shock absorber spring installed length (preload) adjustment (two required)</p>
<p>DRIVE CHAIN & SPROCKET: Driven sprocket/chain link</p>	<p>Standard (2000 – 2001:) (After 2001:) Optional (2000 – 2001:) (After 2001:) (2000 – 2001:) (After 2001:)</p>	<p>52 T (Aluminium)/116 51 T (Aluminium)/114 51 T (Aluminium)/116 50 T (Aluminium)/114 53 T (Aluminium)/116 52 T (Aluminium)/116</p>
<p>HANDLEBAR: Handlebar lower holder</p>	<p>Standard Optional</p>	<p>3 mm (0.12 in) offset No offset</p>
<p>20 INCH FRONT WHEEL (After 2000):</p> <ul style="list-style-type: none"> • Front wheel sub assembly <ul style="list-style-type: none"> – Rim (20 x 1.85) – Spoke – Hub – Distance collar – Wheel bearing – Dust seal • Rim lock (1.85) • Tire (Dunlop D739FA 90/100-20) • Tire flap • Tire tube <p>Front wheel assembly, see page 11-6.</p> <p>RIM TO HUB DISTANCE: STANDARD: 23 mm (0.9 in)</p> <p>WHEEL RIM RUNOUT: SERVICE LIMITS: Radial: 2.0 mm (0.08 in) Axial: 2.0 mm (0.08 in)</p> <p>NOTE:</p> <hr/> <p>Specifications are when using original brake disc, disc bolts and side collars.</p> <hr/> <p>Align the top surface of the top bridge with the top surface of the outer tube.</p>		 







GENERAL INFORMATION

FRAME

ITEM		REMARKS	
FORK:			
Spring	(2000)	TYPE	SPRING RATE
		OIL CAPACITY	
Light	1 scribe mark	0.40 kgf/mm (22.40 lbf/in)	Standard 516 cm ³ (17.5 US oz, 18.2 Imp oz) Maximum 545 cm ³ (18.4 US oz, 19.2 Imp oz) Minimum 482 cm ³ (16.3 US oz, 17.0 Imp oz)
			
Standard	No mark (factory products) or 2 scribe marks (after market parts)	0.42 kgf/mm (23.52 lbf/in)	Standard 518 cm ³ (17.5 US oz, 18.2 Imp oz) Maximum 548 cm ³ (18.5 US oz, 19.3 Imp oz) Minimum 484 cm ³ (16.4 US oz, 17.0 Imp oz)
 			
Heavy	3 scribe marks	0.44 kgf/mm (24.64 lbf/in)	Standard 514 cm ³ (17.4 US oz, 18.1 Imp oz) Maximum 543 cm ³ (18.4 US oz, 19.1 Imp oz) Minimum 480 cm ³ (16.2 US oz, 16.9 Imp oz)
			
	(2001)	TYPE	SPRING RATE
		OIL CAPACITY	
Light	1 scribe mark	0.41 kgf/mm (22.96 lbf/in)	Standard 506 cm ³ (17.1 US oz, 17.8 Imp oz) Maximum 541 cm ³ (18.3 US oz, 19.0 Imp oz) Minimum 477 cm ³ (16.1 US oz, 16.8 Imp oz)
			
Standard	No mark (factory products) or 2 scribe marks (after market parts)	0.43 kgf/mm (24.08 lbf/in)	Standard 502 cm ³ (17.0 US oz, 17.7 Imp oz) Maximum 537 cm ³ (18.2 US oz, 18.9 Imp oz) Minimum 473 cm ³ (16.0 US oz, 16.6 Imp oz)
 			
Heavy	3 scribe marks	0.45 kgf/mm (25.20 lbf/in)	Standard 503 cm ³ (17.0 US oz, 17.7 Imp oz) Maximum 538 cm ³ (18.2 US oz, 18.9 Imp oz) Minimum 474 cm ³ (16.0 US oz, 16.7 Imp oz)
			

The standard fork and shock springs mounted on the motorcycle when it leaves the factory are not marked. Before replacing the springs, be sure to mark them so they are distinguished from the other optional springs.

FRAME

ITEM		REMARKS	
FORK:			
Spring (After 2001)			
TYPE		SPRING RATE	OIL CAPACITY
Light	2 scribe mark 	0.42 kgf/mm (23.52 lbf/in)	Standard 480 cm ³ (16.2 US oz, 16.9 Imp oz) Maximum 553 cm ³ (18.7 US oz, 19.5 Imp oz) Minimum 450 cm ³ (15.2 US oz, 15.8 Imp oz)
Standard	No mark (factory products) or 3 scribe marks (after market parts)  	0.44 kgf/mm (24.64 lbf/in)	Standard 475 cm ³ (16.1 US oz, 16.7 Imp oz) Maximum 548 cm ³ (18.5 US oz, 19.3 Imp oz) Minimum 445 cm ³ (15.0 US oz, 15.7 Imp oz)
Heavy	2 + 2 scribe marks 	0.46 kgf/mm (25.76 lbf/in)	Standard 471 cm ³ (15.9 US oz, 16.6 Imp oz) Maximum 544 cm ³ (18.4 US oz, 19.1 Imp oz) Minimum 440 cm ³ (14.9 US oz, 15.5 Imp oz)
SHOCK ABSORBER:			
Spring			
TYPE		SPRING RATE	IDENTIFICATION MARK
Light		4.5 kgf/mm (252.0 lbf/in)	Purple paint
Standard		4.7 kgf/mm (263.2 lbf/in)	No mark (factory products) or Brown paint (after market parts)
Heavy		4.9 kgf/mm (274.4 lbf/in) 5.1 kgf/mm (285.6 lbf/in)	Black paint Orange paint

The standard fork and shock springs mounted on the motorcycle when it leaves the factory are not marked. Before replacing the springs, be sure to mark them so they are distinguished from the other optional springs.

MEMO



RIDE RED

2. FRAME/BODY PANELS/EXHAUST/SYSTEM

SERVICE INFORMATION	2-1	NUMBER PLATE	2-3
TROUBLESHOOTING	2-1	SUB-FRAME	2-4
SEAT	2-2	FUEL TANK	2-5
SIDE COVERS	2-2	EXHAUST PIPE	2-6
RADIATOR SHROUD	2-3		

SERVICE INFORMATION

GENERAL

⚠ WARNING

- *Gasoline is extremely flammable and is explosive under certain condition. KEEP OUT OF REACH OF CHILDREN.*
- *Serious burns may result if the exhaust system is not allowed to cool before components are removed or serviced.*

- Work in a well ventilated area. Smoking or allowing flames or sparks in the work area or where gasoline is stored can cause a fire or explosion.
- This section covers removal and installation of the body panels, fuel tank and exhaust system.
- Always replace the exhaust pipe gaskets after removing the exhaust pipe from the engine.
- Always inspect the exhaust system for leaks after installation.

TORQUE VALUES

Seat mounting bolt	26 N•m (2.7 kgf•m, 20 lbf•ft)
Sub-frame mounting bolt (upper)	29 N•m (3.0 kgf•m, 22 lbf•ft)
Seat bracket screw	6 N•m (0.6 kgf•m, 4.3 lbf•ft)
Front chamber stay bolt	12 N•m (1.2 kgf•m, 9 lbf•ft)
Footpeg bracket bolt (upper)	54 N•m (5.5 kgf•m, 40 lbf•ft)
(lower)	42 N•m (4.3 kgf•m, 31 lbf•ft)

TROUBLESHOOTING

Excessive exhaust noise

- Broken exhaust system
- Exhaust gas leak

Poor performance

- Deformed exhaust system
- Exhaust gas leak
- Clogged muffler

SEAT

REMOVAL

Remove the two bolts, collars and seat.

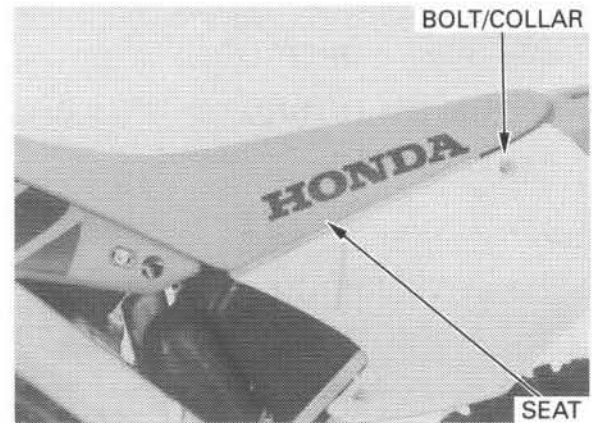

INSTALLATION

Align the hook of the seat with the mounting screw on the fuel tank and the seat prongs with the sub-frame tabs. Install and tighten the seat mounting bolts to the specified torque.

TORQUE: 26 N·m (2.7 kgf·m, 20 lbf·ft)

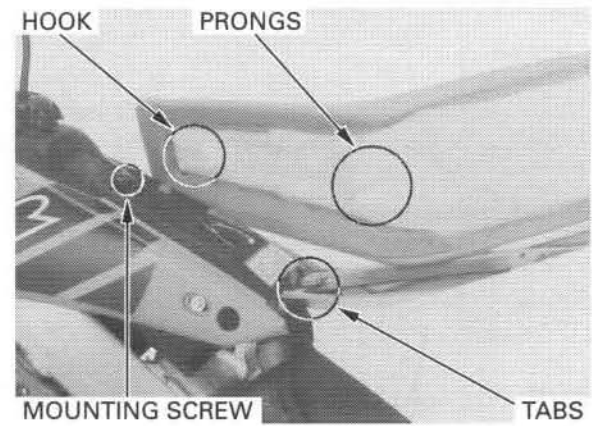

SIDE COVERS

REMOVAL/INSTALLATION

Remove the seat mounting bolts.
Remove the flange bolts, collars and side cover.

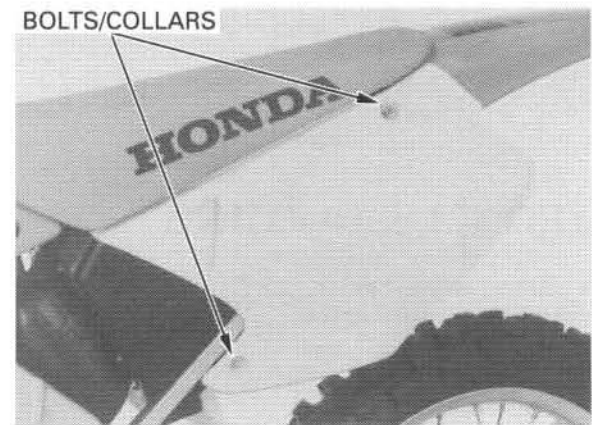

Be careful not to damage the tabs.

Install the side cover in the reverse order of removal.

Tighten the seat mounting bolts to the specified torque.

TORQUE: 26 N·m (2.7 kgf·m, 20 lbf·ft)



RADIATOR SHROUD

REMOVAL/INSTALLATION

Note that the thinner collars are in the upper bolts.

Remove the bolts, collars and radiator shroud.

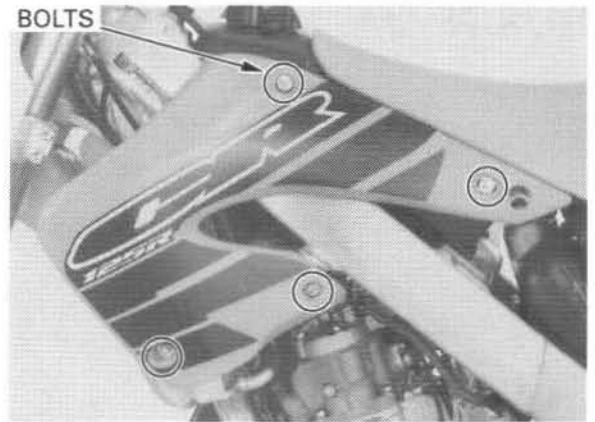

Insert the tab inside the seat.

Installation is in the reverse order of removal.

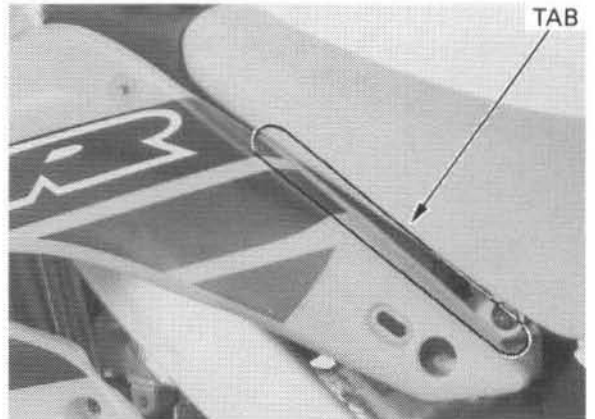

NUMBER PLATE

REMOVAL/INSTALLATION

Remove the number plate tab from the handlebar. Remove the bolt, collar and number plate.

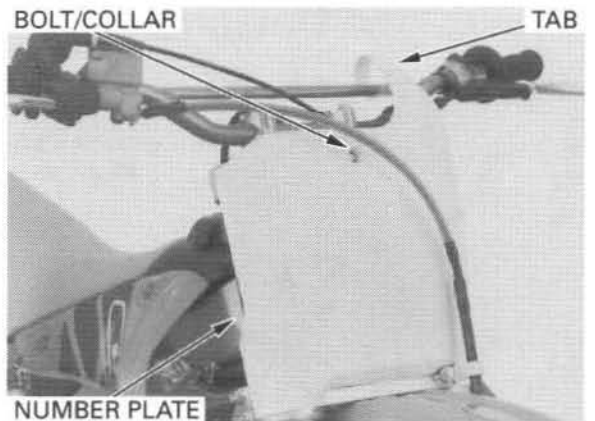

Install the number plate aligning its hole and pin on the steering stem.

Installation is in the reverse order of removal.

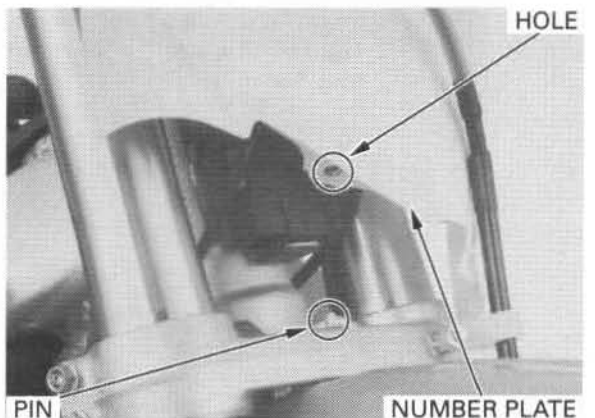

SUB-FRAME

REMOVAL

Remove the seat (page 2-2).

Loosen the air cleaner connecting tube band screw.

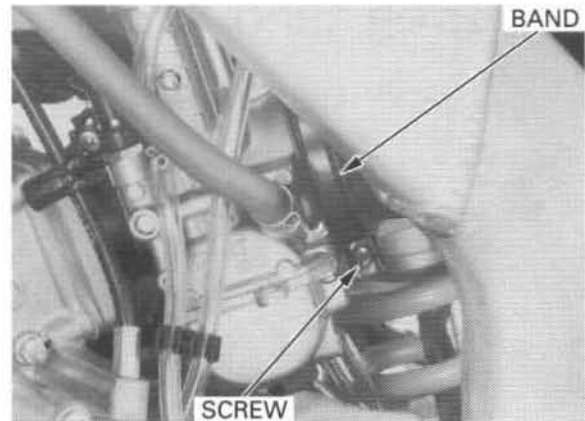

Remove the three sub-frame mounting bolts. Remove the sub-frame by pulling it straight backwards.

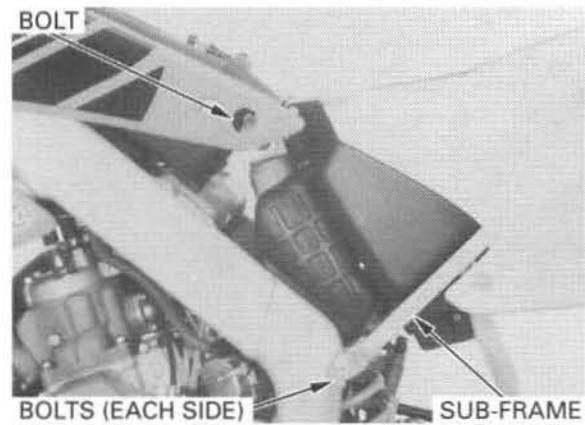

INSTALLATION

Loosely attach the upper and lower ends of the sub-frame to the main-frame while connecting the expansion chamber to the silencer pipe with the sealing rubber and the air cleaner connecting tube to the carburetor.

Tighten the screw on the connecting tube clamp.

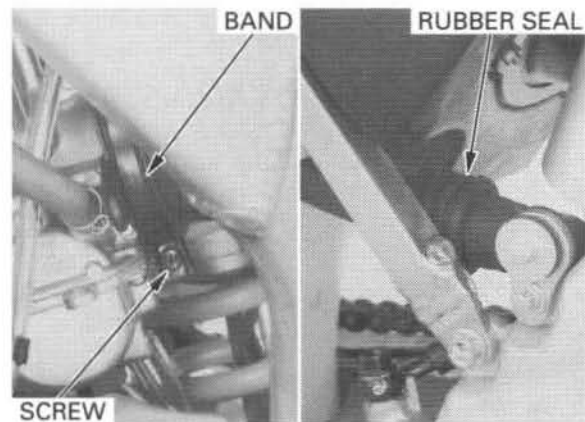

Snug but do not tighten the three attaching bolts. Tighten the sub-frame mounting bolts to the specified torque.

TORQUE:

Upper: 29 N·m (3.0 kgf·m, 22 lbf·ft)

Install the seat (page 2-2).

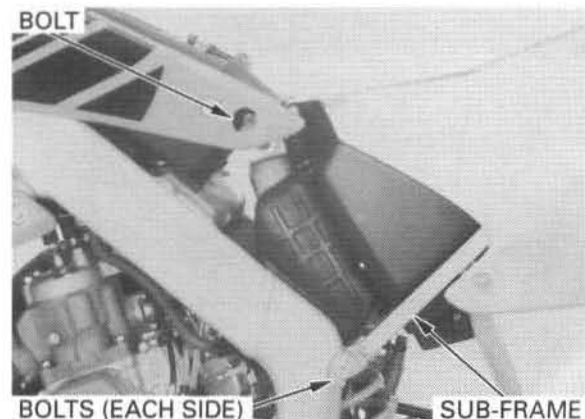

FUEL TANK

⚠ WARNING

Gasoline is extremely flammable and is explosive under certain conditions. KEEP OUT OF REACH OF CHILDREN.

FUEL FILTER MAINTENANCE

Drain the fuel from fuel tank into an approved gasoline container.
Disconnect the fuel line from the fuel valve.
Remove the bolts, collars and fuel valve.

Wash the fuel filter in high flash point cleaning solvent.

Check the O-ring is in good condition, install it onto the fuel valve.

After installation, make sure there are no fuel leaks.

Install the fuel valve in the reverse order of removal.

REMOVAL/INSTALLATION

Remove the seat (page 2-2).
Remove the radiator shrouds (page 2-3).

Turn the fuel valve OFF, and disconnect the fuel line.

Remove the fuel tank mounting bolt, unhook the band and remove the fuel tank.

After installation, make sure there are no fuel leaks.

Installation is in the reverse order of removal.

Install the breather hose into the stem nut as shown.

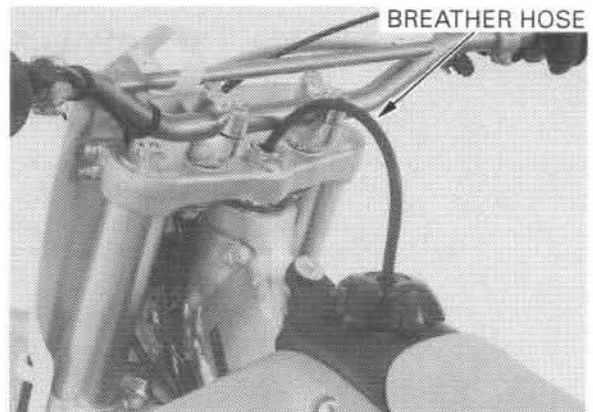
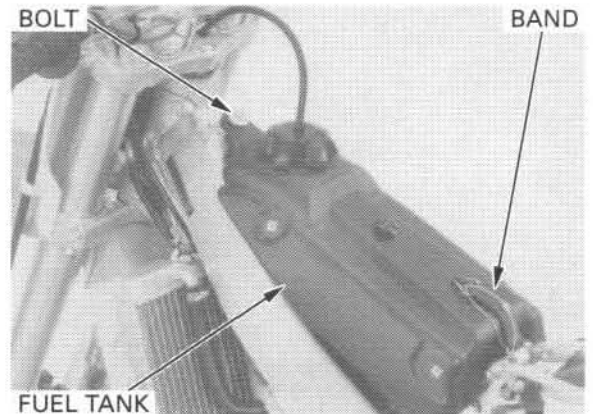
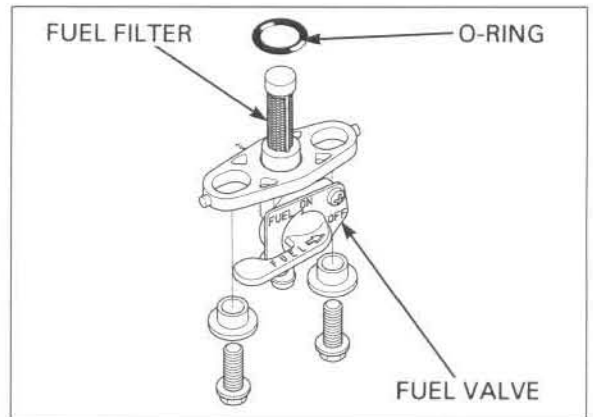
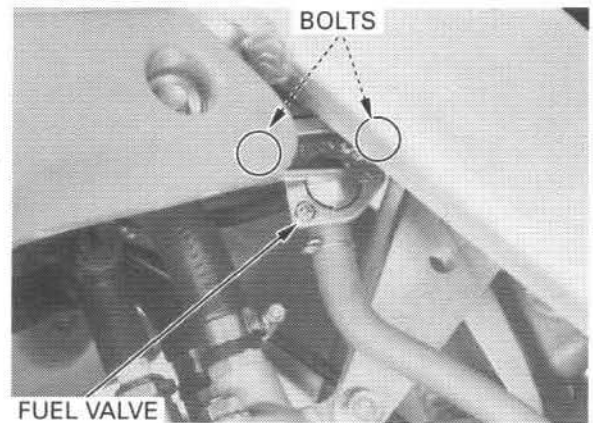

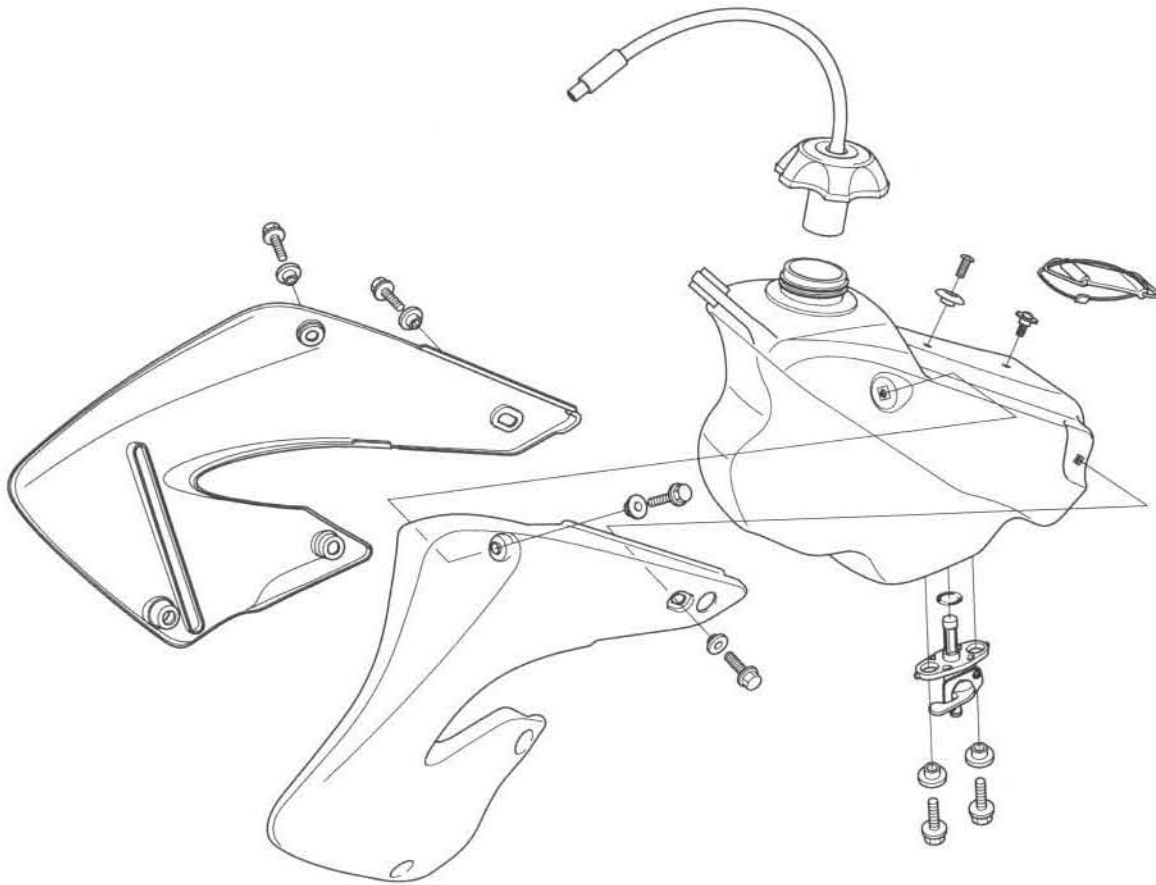

EXHAUST PIPE

⚠ WARNING

Do not service the exhaust system while it is hot.

SILENCER REMOVAL/INSTALLATION

Remove the right side cover (page 2-2).

Remove the silencer case mounting bolt, silencer case and sealing rubber.

Check the sealing rubber for wear or damage. Replace the sealing rubber if necessary.

If necessary, perform glass wool packing maintenance (page 3-16).

Installation is in the reverse order of removal.

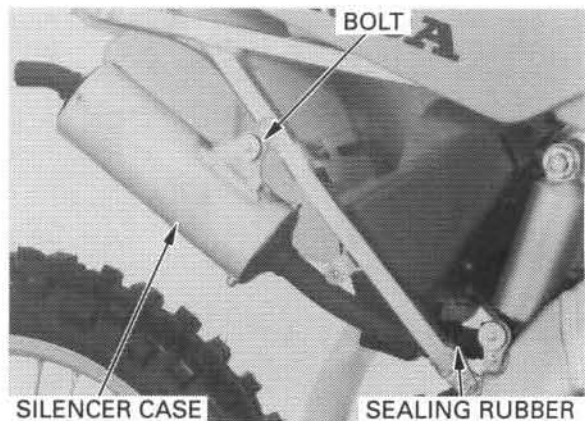

EXPANSION CHAMBER REMOVAL/INSTALLATION

Remove the seat and right side cover (page 2-2).

Loosen the chamber bracket bolts.

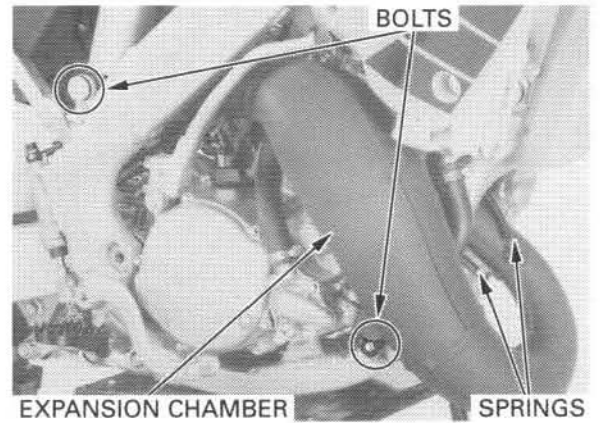

Always replace the expansion chamber gaskets with new ones.

Unhook and remove the chamber springs.
Remove the mounting bolts and expansion chamber.

Installation is in the reverse order of removal.

TORQUE:

FRONT CHAMBER STAY BOLT:
12 N•m (1.2 kgf•m, 9 lbf•ft)

Install the sealing rubber securely.

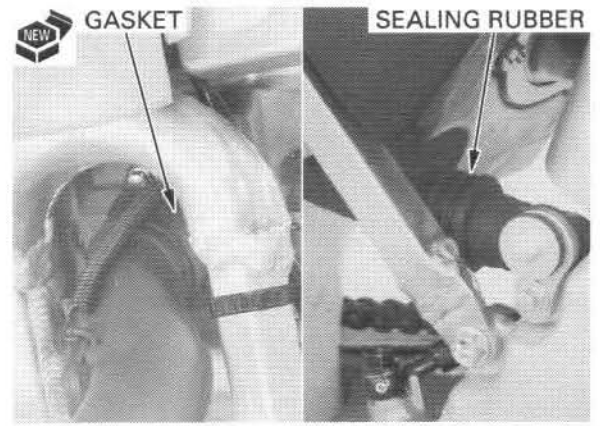

MEMO



3. MAINTENANCE

SERVICE INFORMATION	3-1	DRIVE/DRIVEN SPROCKETS	3-13
MAINTENANCE SCHEDULE	3-3	BRAKE FLUID	3-13
THROTTLE OPERATION	3-5	BRAKE PAD WEAR	3-14
AIR CLEANER	3-5	BRAKE SYSTEM	3-14
SPARK PLUG	3-6	CLUTCH SYSTEM	3-15
RADIATOR COOLANT	3-8	CONTROL CABLES	3-16
COOLING SYSTEM	3-8	EXPANSION CHAMBER/SILENCER	3-16
CYLINDER HEAD DECARBONIZING	3-8	SUSPENSION	3-17
EXHAUST VALVE DECARBONIZING	3-9	SWINGARM/SHOCK LINKAGE	3-18
TRANSMISSION OIL	3-9	NUTS, BOLTS, FASTENERS	3-19
DRIVE CHAIN	3-10	WHEELS/TIRES	3-19
DRIVE CHAIN SLIDERS	3-12	STEERING HEAD BEARINGS	3-19
DRIVE CHAIN ROLLERS	3-12		

SERVICE INFORMATION

GENERAL

⚠ WARNING

- Gasoline is extremely flammable and is explosive under certain conditions. Work in a well ventilated area. Smoking or allowing flames or sparks in the work area or where the gasoline is stored can cause a fire or explosion.
- If the engine must be running to do some work, make sure the area is well ventilated. Never run the engine in an enclosed area. The exhaust contains poisonous carbon monoxide gas that may cause loss of consciousness and may lead to death.

- Place the motorcycle on a level ground before starting any work.

SPECIFICATIONS

ITEM		SPECIFICATIONS
Throttle grip free play		3 – 5 mm (1/8 – 1/4 in)
Spark plug	Standard: (NGK)	BR9EG
	Standard: (DENSO)	W27ESR-V
	Option: (NGK)	BR9EV
	Option: (DENSO)	W27ESR-G
Spark plug gap		0.5 – 0.6 mm (0.020 – 0.024 in)
Transmission oil capacity	at draining	0.57 liter (0.60 US qt, 0.50 Imp qt)
	at oil filter change	0.65 liter (0.69 US qt, 0.57 Imp qt)
Recommended transmission oil		Pro-Honda HP Trans Oil, Pro-Honda GN4 4-Stroke Oil or equivalent motor oil API service classification SF or SG Viscosity: SAE10W-40

MAINTENANCE

ITEM		SPECIFICATIONS
Clutch lever free play		10 – 20 mm (3/8 – 3/4 in)
Drive chain slack		25 – 35 mm (1 – 1-3/8 in)
Chain tensioner O.D.		25 mm (1.0 in) minimum
Chain slider		5 mm (0.2 in) minimum
Tire size	Front	80/100 – 21 51M
	Rear	100/90 – 18 57M
Tire air pressure	Front	100 kPa (1.0 kgf/cm ² , 14 psi)
	Rear	100 kPa (1.0 kgf/cm ² , 14 psi)

TORQUE VALUES

Oil check bolt	10 N•m (1.0 kgf•m, 7 lbf•ft)
Oil drain bolt	29 N•m (3.0 kgf•m, 22 lbf•ft)
Spark plug	18 N•m (1.8 kgf•m, 13 lbf•ft)
Rear axle nut	128 N•m (13.0 kgf•m, 94 lbf•ft)
Drive chain adjusting bolt lock nut	26 N•m (2.7 kgf•m, 20 lbf•ft)
Drive chain roller bolt (2000:)	22 N•m (2.2 kgf•m, 16 lbf•ft)
(After 2000:)	12 N•m (1.2 kgf•m, 9 lbf•ft)
Brake lever adjuster lock nut	6 N•m (0.6 kgf•m, 4.3 lbf•ft)
Front master cylinder reservoir cover bolt	1 N•m (0.1 kgf•m, 0.7 lbf•ft)
Rear master cylinder reservoir cover bolt	1 N•m (0.1 kgf•m, 0.7 lbf•ft)
(After 2001:)	1.2 N•m (0.12 kgf•m, 0.87 lbf•ft)
Fork air pressure release screw	4 N•m (0.4 kgf•m, 3.0 lbf•ft)
Spoke nipple	4 N•m (0.4 kgf•m, 3.0 lbf•ft)
Rim lock	13 N•m (1.3 kgf•m, 9 lbf•ft)

MAINTENANCE SCHEDULE

Perform the Pre-ride inspection in the Owner's Manual at each scheduled maintenance period.

I: Inspect and Clean, Adjust, Lubricate or Replace if necessary. C: Clean. R: Replace. A: Adjust. L: Lubricate.

ITEMS	FREQUENCY	NOTE	Each	Every 3	Every 9	REFER TO PAGE
			race or about 2.5 hours	races or about 7.5 hours	races or about 22.5 hours	
THROTTLE OPERATION			I			3-5
AIR CLEANER		NOTE 1	C			3-5
SPARK PLUG			I	R		3-6
RADIATOR COOLANT		NOTE 2	I			3-8
COOLING SYSTEM			I			3-8
CYLINDER HEAD DECARBONIZING				C		3-8
EXHAUST VALVE DECARBONIZING			C			3-9
PISTON AND PISTON RING				R		7-8, 9
PISTON PIN AND CONNECTING ROD SMALL END BEARING					R	7-10
REED VALVE ONLY				R		4-15
TRANSMISSION OIL				R		3-9
DRIVE CHAIN			I, L	R		3-10
DRIVE CHAIN SLIDER			I			3-12
DRIVE CHAIN ROLLER			I			3-12
DRIVE SPROCKET			I			3-13
DRIVEN SPROCKET			I			3-13
BRAKE FLUID		NOTE 2	I			3-13
BRAKE PADS WEAR			I			3-14
BRAKE SYSTEM			I			3-14
CLUTCH SYSTEM			I			3-15
CONTROL CABLES			I, L			3-16
EXPANSION CHAMBER/SILENCER			I			3-16
SUSPENSION			I			3-17
SWINGARM/SHOCK LINKAGE				L		3-18 12-27, 32
FORK OIL		NOTE 3		R		11-19
NUTS, BOLTS, FASTENERS			I			3-19
WHEELS/TIRES			I			3-19
STEERING HEAD BEARINGS					I	3-19

This maintenance schedule is based upon average riding conditions. Machines subjected to severe use require more frequent servicing.

- NOTES: 1. Clean after every moto for dusty riding conditions.
 2. Replace every 2 years. Replacement requires mechanical skill.
 3. Replace after the first break-in ride.

MAINTENANCE

ADDITIONAL ITEMS REQUIRING FREQUENT REPLACEMENT

ENGINE	ITEM	CAUSE	REMARKS
	Cylinder head gasket	Compression leak	Replace whenever disassembled
	Clutch disc	Wear or discoloration	
	Cylinder base gasket	Leakage	Replace whenever disassembled
	Right crankcase cover gasket	Damage	Replace whenever disassembled
	Exhaust valve cover gasket	Damage	

FRAME	ITEM	CAUSE	REMARKS
	Front/rear tire	Wear	Minimum cleat height: 8 mm (5/16 in)
	Front/rear brake pad	Wear	Minimum thickness: 1 mm (0.04 in)
	Sub-frame mounting bolts	Fatigue or damage	
	Drive chain guide plate	Wear or damage	
	Side cover	Damage	
	Front number plate	Damage	
	Front/rear fender	Damage	
	Clutch lever/holder	Play or damage	
	Brake lever	Play or damage	
	Handlebar	Bent or cracked	
	Throttle housing	Damage	
	Grip rubber	Damage	
	Gearshift pedal	Damage	
	Brake pedal	Damage	
	Drive chain adjuster/bolt	Damage	
	Air cleaner	Damage	
	Exhaust chamber spring/hook	Fatigue or damage	

NOTE: These parts and their possible replacement schedule are based upon average riding conditions. Machines subjected to severe use require more frequent servicing.

THROTTLE OPERATION

Check for smooth throttle grip full opening and automatic full closing in all steering positions. Check the throttle cable and replace them if they are deteriorated, kinked or damaged. Lubricate the throttle cable, if throttle operation is not smooth.

Measure the free play at the throttle grip flange.

FREE PLAY: 3 – 5 mm (1/8 – 1/4 in)

Throttle grip free play can be adjusted at either end of the throttle cable.

Minor adjustments are made with the upper adjuster. Remove the dust cover from the adjuster. Adjust the free play by loosening the lock nut and turning the adjuster.

Tighten the lock nut after making the adjustment. Reinstall the dust cover.

Major adjustments are made with the carburetor end of the cable.

Pull the carburetor rubber cap up. Adjust the free play by loosening the lock nut and turning the adjuster.

After adjustment, tighten the lock nut securely and reinstall the rubber cap. Recheck the throttle operation.

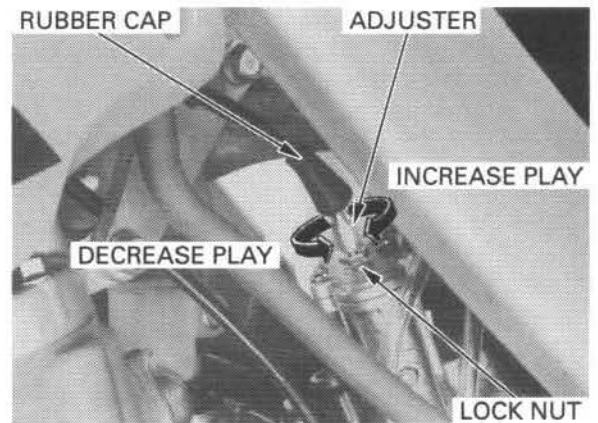
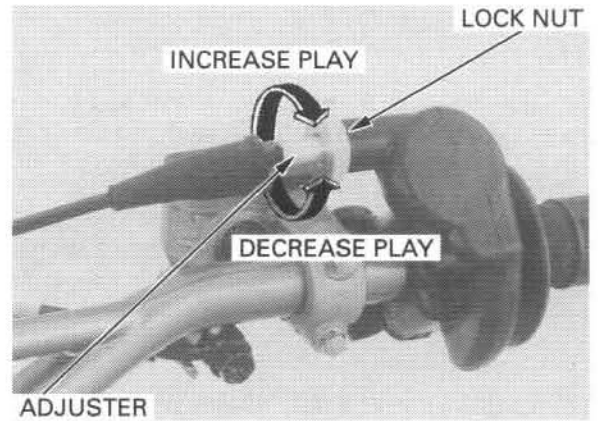
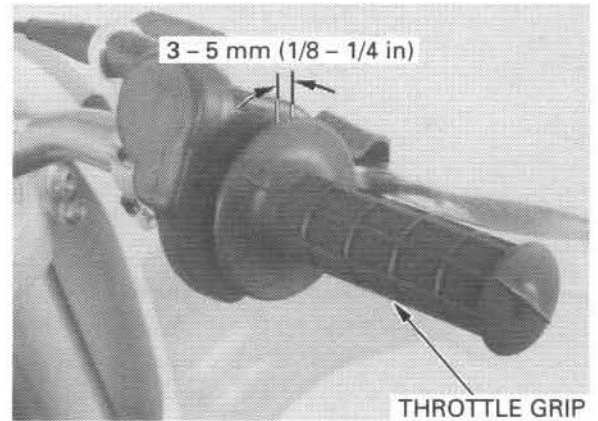

AIR CLEANER

Remove the seat (page 2-2).

Loosen the air cleaner retaining bolt.

Remove the air cleaner assembly.

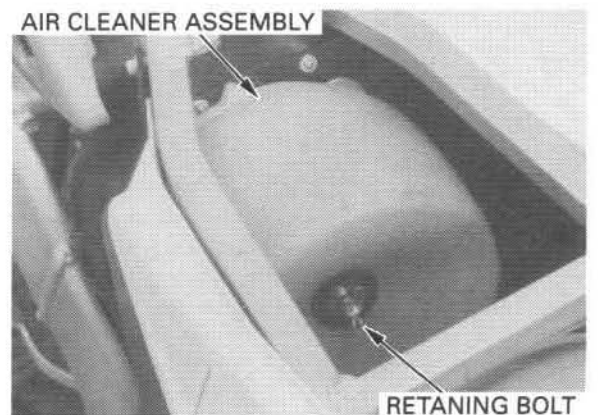

MAINTENANCE

Remove the air cleaner from the cleaner holder.

Thoroughly wash the air cleaner in clean non-flammable or high flash point cleaning solvent. Then wash the element again in a solution of hot water and dishwashing liquid soap. Clean the inside of the air cleaner housing.

⚠ WARNING

Never use gasoline or low flash point solvents for cleaning the air filter element. A fire or explosion could result.

After cleaning, be sure there is no dirt or sand trapped between the inner and outer layer of the cleaner.

Wash again if necessary.

Allow the air cleaner to dry thoroughly. After drying, soak the air cleaner in clean Honda Foam Filter Oil or an equivalent.

Apply air filter oil to the entire surface of the air cleaner and rub it with both hands to saturate the element with oil.

Gently squeeze out excess oil. It is important not to over-oil, or under-oil the element.

Apply a thin coat of Honda White Lithium Grease or an equivalent to the sealing surface.

Assemble the air cleaner on to the holder. Slip the air cleaner retaining bolt through the assembly.

Align the air cleaner tab with the "△" mark on the housing and install it.

Tighten the retaining bolt securely.

Install the seat (page 2-2).

CAUTION:

If the air cleaner assembly is not installed correctly, dirt and dust may enter the engine resulting wear of the piston ring and cylinder.

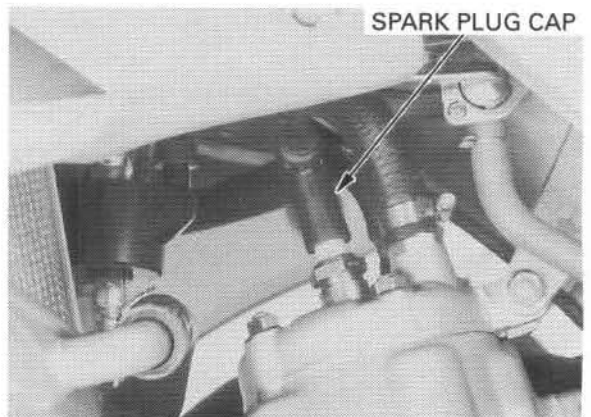
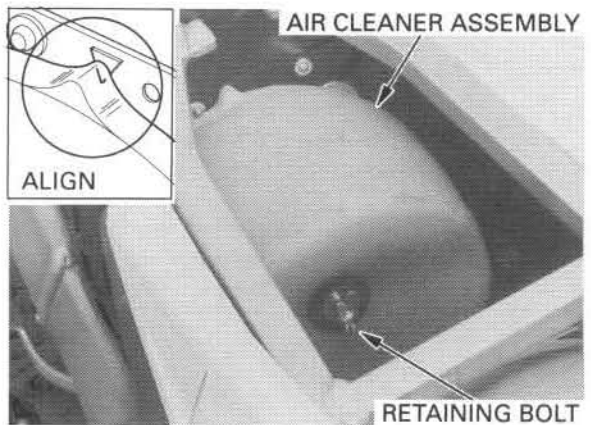
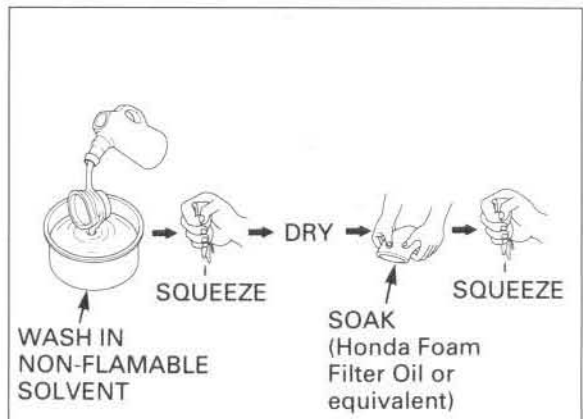
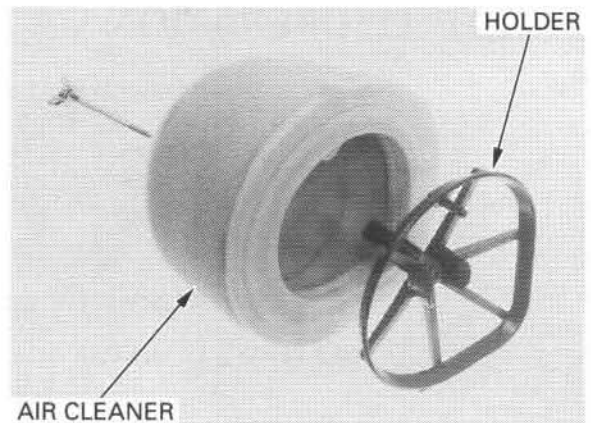

SPARK PLUG

Disconnect the spark plug cap.

NOTE:

Clean around the spark plug bases with compressed air before removing, and be sure that no debris is allowed to enter the combustion chamber.

Remove the spark plug and inspect it for damage.

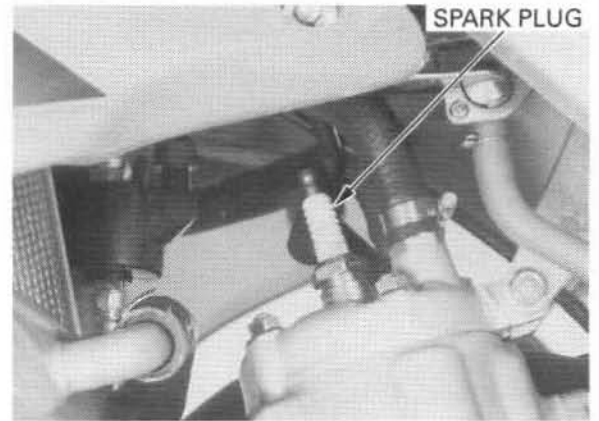

Check the following and replace if necessary:

- Insulator for damage
- Electrodes for wear
- Burning condition, coloration on plug:
 - dark to light brown indicates good condition.
 - excessive lightness indicates malfunctioning ignition system or lean mixture.
 - wet or black sooty deposit indicates over-rich mixture.

RECOMMENDED SPARK PLUG (OR EQUIVALENT)

NGK	BR9EG [BR9EV]
DENSO	W27ESR-V [W27ESR-G]
[]: Optional

If necessary, adjust the gap by carefully bending the side electrode. Then measure the gap again and reinstall.

SPARK PLUG GAP: 0.5 – 0.6 mm (0.020 – 0.024 in)

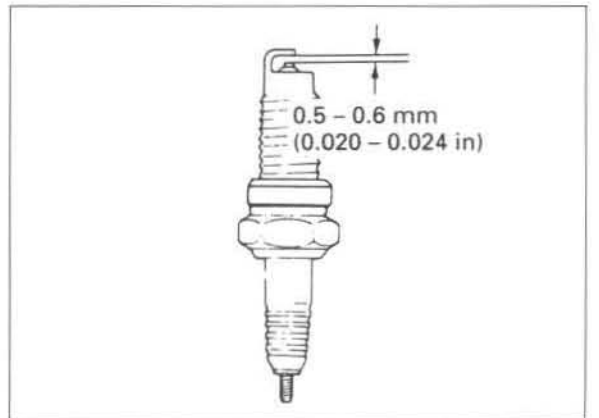
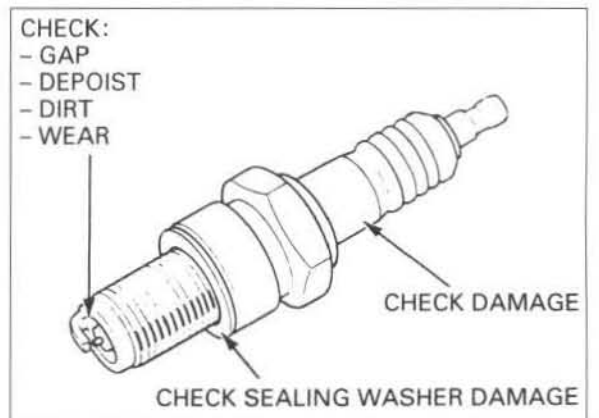

CAUTION:

To prevent damage to the cylinder head, hand-tighten the spark plug before using a wrench to tighten to the specified torque.

Reinstall the spark plug in the cylinder head and hand tighten, then torque to specification.

TORQUE: 18 N·m (1.8 kgf·m, 13 lbf·ft)

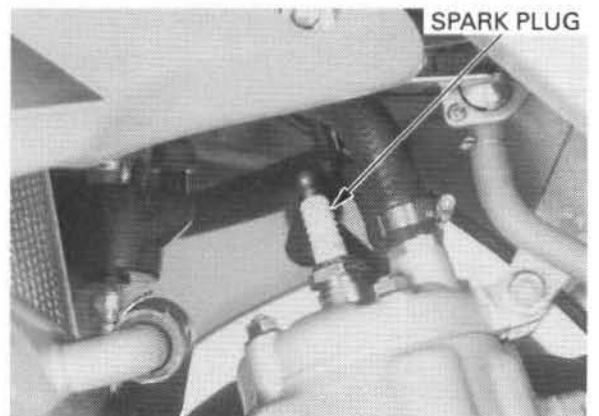

RADIATOR COOLANT

⚠ WARNING

- *Wait until the engine is cool before removing the radiator cap. Removing the cap while the engine is hot and the coolant is under pressure may cause serious scalding.*
- *Radiator coolant is poisonous. Take care to avoid getting coolant in your eye, on your skin, or on your clothes.*
- *If coolant gets in your eye, flush repeatedly with water and contact a doctor immediately.*
- *If coolant is accidentally swallowed, induce vomiting and contact a doctor immediately.*
- **KEEP OUT REACH OF CHILDREN.**

Remove the radiator cap.

Check the coolant level with the engine cold, it should be up to the filler neck.

Add coolant as required (page 5-3).

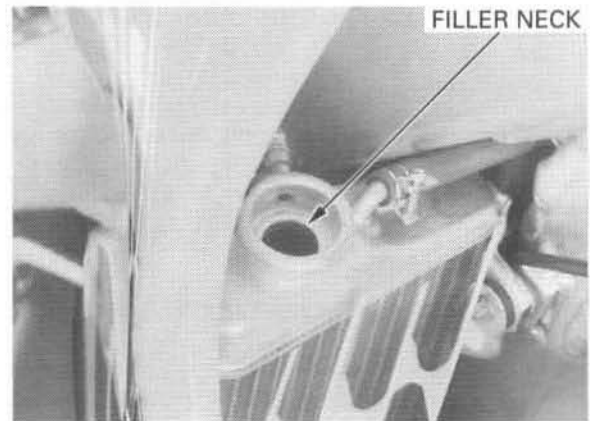
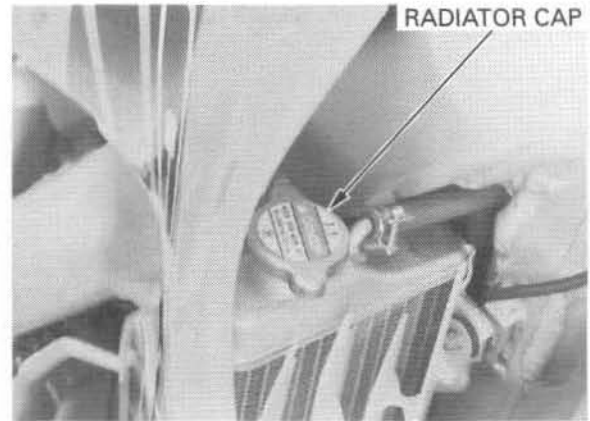

COOLING SYSTEM

Remove the radiator shrouds (page 2-3).

Check the radiator air passage for clogging or damage.
Inspect the hoses for cracks and deterioration.

Use low pressure water and a soft brush to rinse off any dirt that may be stuck in the radiator core.
Inspect the hoses for cracks and deterioration.
Replace if necessary. Check the tightness of the hose clamps and radiator mounting bolts.

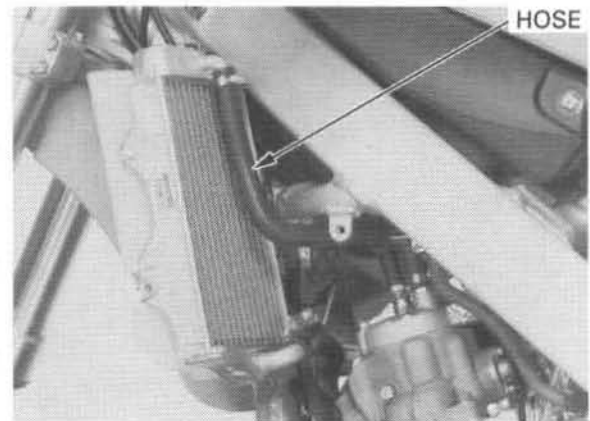

CYLINDER HEAD DECARBONIZING

Remove the cylinder head (page 7-3).

Clean the cylinder head surface of any gasket material.
Remove the carbon deposits from the combustion chamber.

NOTE:

- Decarbonize the cylinder head every 3 races or about 7.5 hours.
- Use care not to scratch the combustion chamber or the head gasket surface.

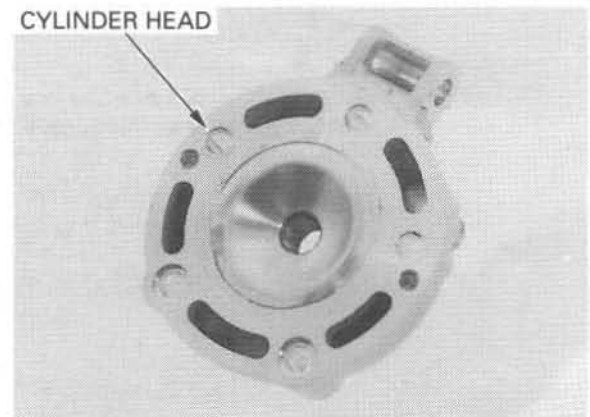

EXHAUST VALVE DECARBONIZING

Remove the flap valves and valve shaft (page 8-4).

Remove the carbon deposits from the flap valves and valve shaft.
Inspect the flap valves and valve shaft for wear or damage.

NOTE:

Decarbonize the flap valves and valve shaft after each race.

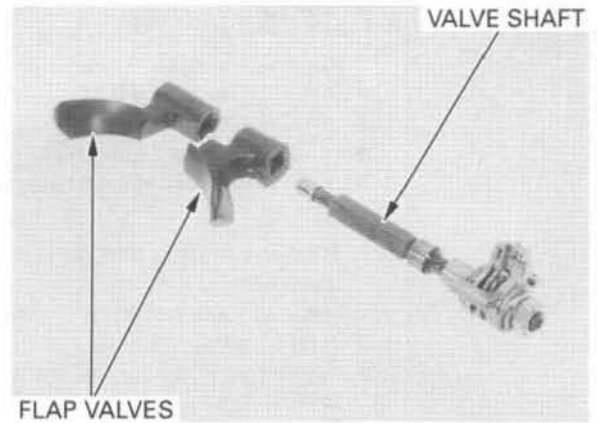

TRANSMISSION OIL

OIL LEVEL INSPECTION

⚠ WARNING

If the engine must be running to do some work, make sure the area is well-ventilated. Never run the engine in an enclosed area.

1. Start the engine and let it idle for 2 – 3 minutes.
2. Wait three minutes after shutting off the engine to allow the oil to properly distribute itself in the clutch and transmission.
3. Support the motorcycle in an upright position on level ground.
4. Remove the oil filler cap and check bolt from the right crankcase cover. A small amount of oil should flow out of the check bolt hole. Allow any excess oil to flow out of the check bolt hole.
5. If no oil flows out of the check bolt hole, add oil slowly through the oil filler hole until oil starts to flow out of the check bolt hole. Install the oil check bolt and filler cap.
6. Repeat steps 1 – 4.
7. After checking the oil level or adding oil, tighten the oil check bolt and filler cap securely.

TORQUE: 10 N·m (1.0 kgf·m, 7 lbf·ft)

TRANSMISSION OIL CHANGE

NOTE:

- Transmission oil should be changed at least every 3 races or 7.5 hours of running to ensure consistent performance and maximum service life of both transmission and clutch components.
- Warm-up the engine before draining the oil. This will ensure complete and rapid draining.

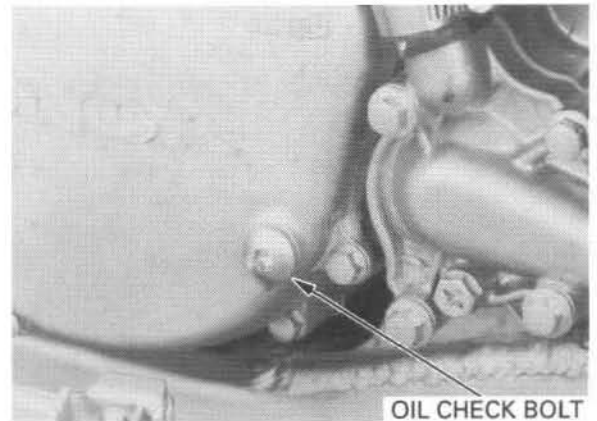
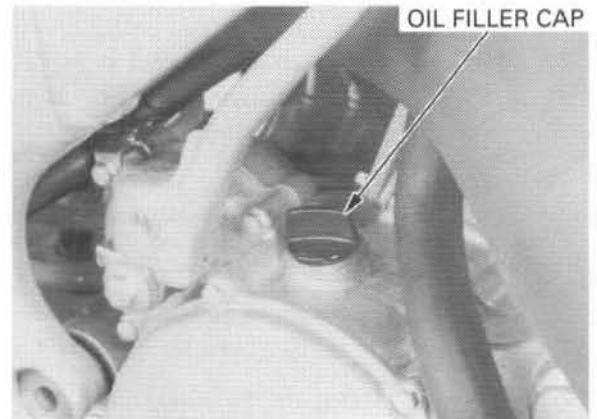

⚠ WARNING

If the engine must be running to do some work, make sure the area is well-ventilated. Never run the engine in an enclosed area. The exhaust contains poisonous carbon monoxide gas that may cause loss of consciousness and may lead to death.

1. Start the engine and let it idle for two or three minutes.
2. Support the motorcycle in an upright position on level ground.
3. Remove the oil filler cap from the right crankcase cover.
4. Place an oil pan under the engine to catch the oil, then remove the drain bolt.

⚠ WARNING

Used transmission oil may cause skin cancer if repeatedly left in contact with the skin for prolonged periods. Although this is unlikely unless you handle used oil on a daily basis, it is still advisable to thoroughly wash your hands with soap and water as soon as possible after handling used oil.

5. After the oil has drained completely, install the drain bolt with a new sealing washer.

TORQUE: 29 N·m (3.0 kgf·m, 22 lbf·ft)

6. Add the recommended oil.

OIL CAPACITY:

0.57 liter (0.60 US qt, 0.50 Imp qt) at draining

RECOMMENDED TRANSMISSION OIL:

Pro-Honda HP Transmission oil, GN4 4-stroke Oil or equivalent motor oil

API service classification: SF or SG

Viscosity: 10W-40

Check the oil level by following steps 1 – 6 in oil level check procedure (page 3-9).

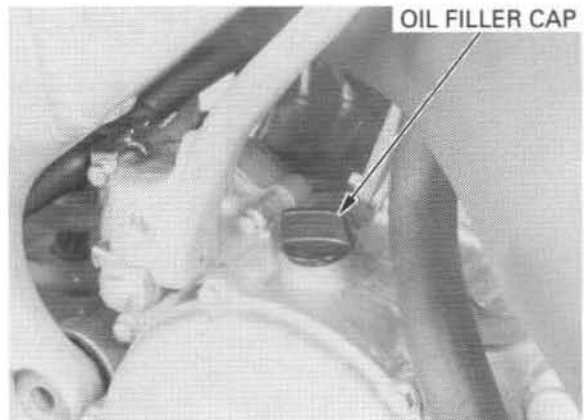

DRIVE CHAIN

⚠ WARNING

Never inspect and adjust the drive chain while the engine is running.

NOTE:

For maximum service life, the drive chain should be cleaned and lubricated after each outing.

Perform the following service with the engine stopped and the transmission into neutral.

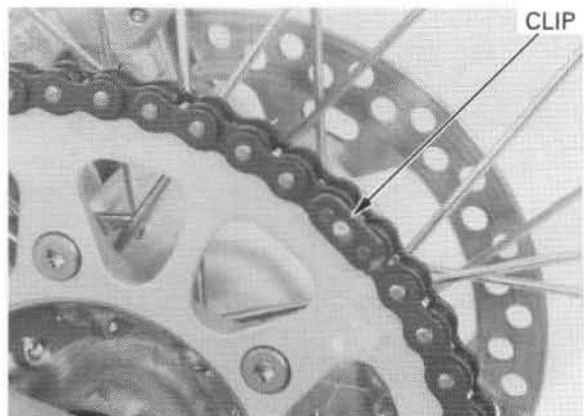

Place a workstand under the engine.

Carefully remove the master link clip with pliers. Remove the master link and the drive chain.

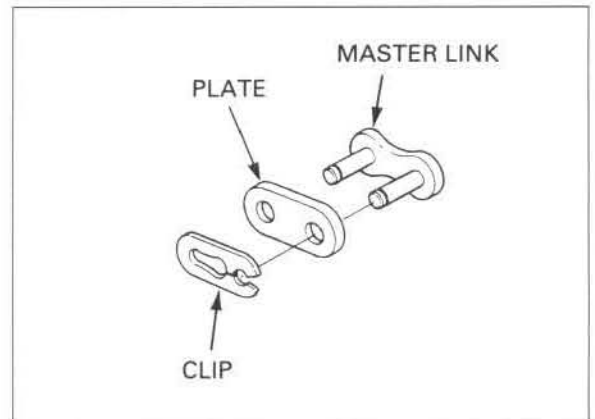

Clean the drive chain in non-flammable or high flash point solvent and wipe it dry.

Inspect the chain for possible wear or damage; replace any chain that has damaged rollers or loose fitting links.

Reinstall the drive chain and lubricate it with Pro Honda Chain Lube or its equivalent.

Install the open end of the master link opposite the direction of chain travel.

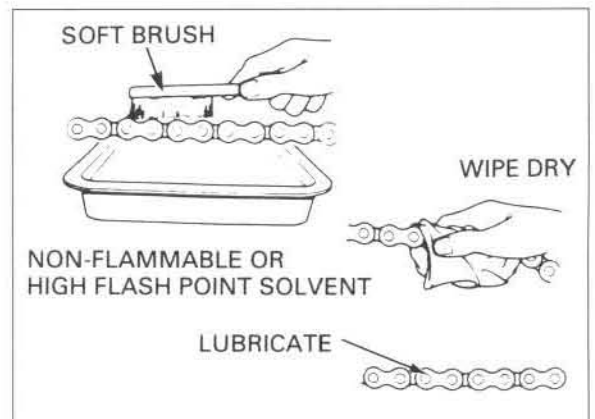

Measure the distance between a span of 17 pins (16 pitches), from pin center to pin center.

SERVICE LIMIT: 258.0 mm (10.16 in)

If the measurement exceeds the service limit, replace the chain.

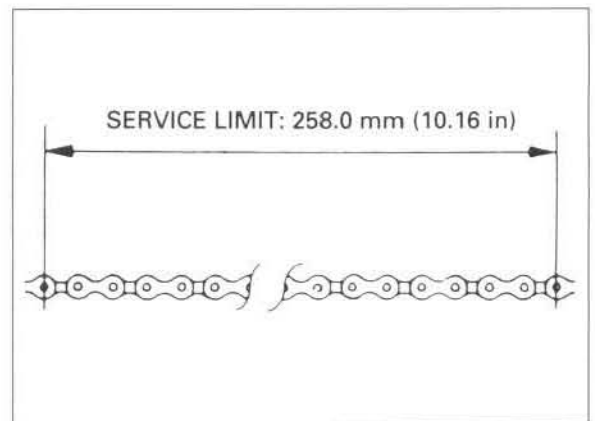

ADJUSTMENT

Raise the rear wheel off the ground by placing a workstand under the engine.

Measure the chain slack, in the upper chain run, midway between the sprockets.

CHAIN SLACK: 25 – 35 mm (1.0 – 1.4 in)

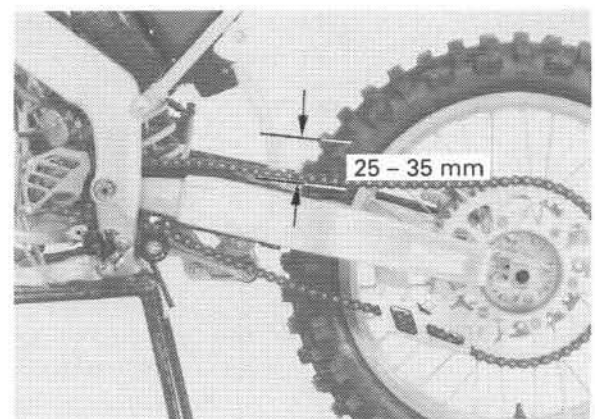

MAINTENANCE

If the chain needs adjustment, loosen the axle nut and adjuster lock nuts, and turn the adjusting bolts.

Check that the chain adjuster index marks are in the same position on each side, then tighten the axle nut to the specified torque.

TORQUE: 128 N·m (13.0 kgf·m, 94 lbf·ft)

After torquing the axle nut, seat the adjusting bolts snugly against the axle adjustment plates and tighten the adjuster lock nut to the specified torque.

TORQUE: 26 N·m (2.7 kgf·m, 20 lbf·ft)

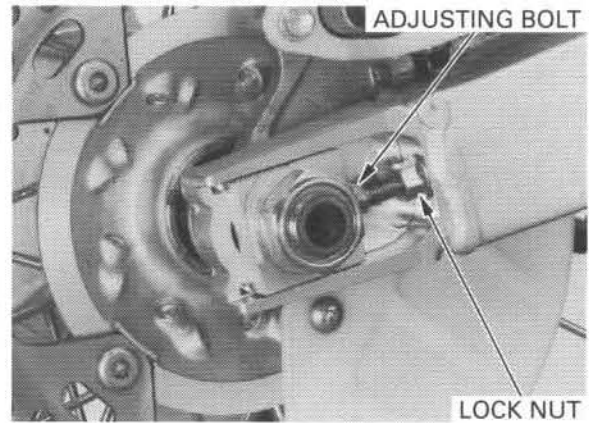

DRIVE CHAIN SLIDERS

Inspect the drive chain slider for excessive wear.

SERVICE LIMIT: 5 mm (0.2 in) from upper surface

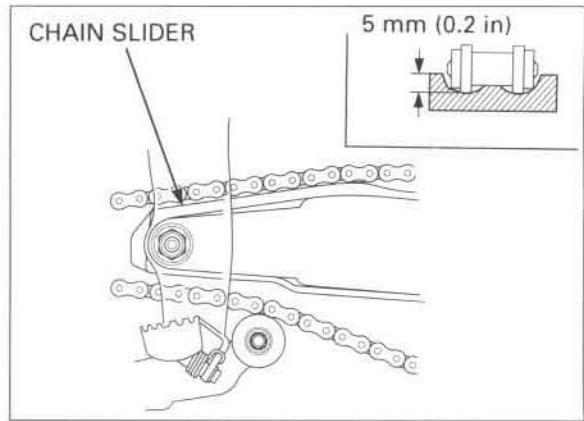

Check the chain guide and chain guide slider for alignment, wear or damage.

Replace the chain guide if it is damaged or worn.

Replace the chain guide slider if the chain is visible through the wear inspection window.

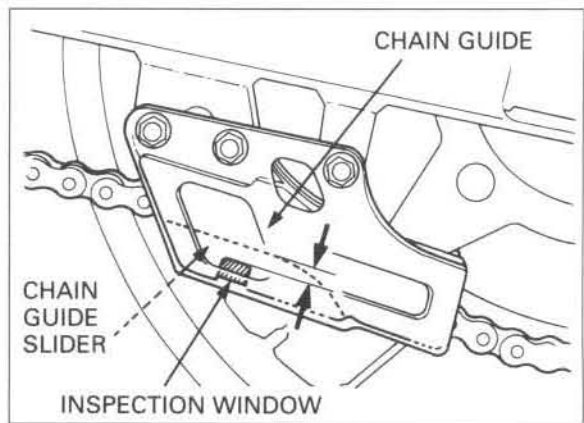

DRIVE CHAIN ROLLERS

Inspect the drive chain rollers for excessive wear or binding.

SERVICE LIMIT:

Minimum roller O.D.: 25 mm (1.0 in)

Install the lower (After 2001: upper) drive chain roller with its "→" mark side facing out.

Replace the roller if necessary, and tighten the roller bolts to the specified torque.

TORQUE:

(2000:) 22 N·m (2.2 kgf·m, 16 lbf·ft)

(After 2000:) 12 N·m (1.2 kgf·m, 9 lbf·ft)

NOTE:

Install the drive chain rollers as follows:
Upper: Bearing shield color is orange
Lower: Bearing shield color is black

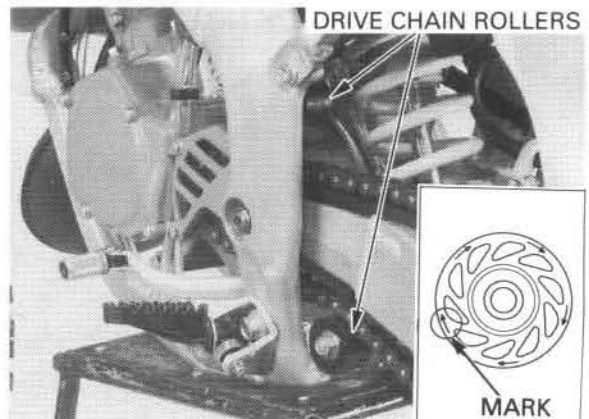

DRIVE/DRIVEN SPROCKETS

Never use a new drive chain on worn sprockets. Inspect the drive and driven sprocket teeth for wear or damage, replace if necessary.

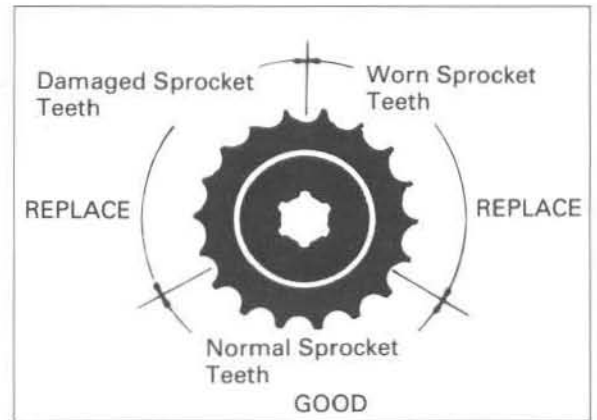

BRAKE FLUID

CAUTION:

- Do not mix different types of fluid, as they are not compatible with each other.
- Do not allow foreign material to enter the system when filling the reservoir.
- Avoid spilling fluid on painted, plastic or rubber parts. Place a rag over these parts whenever the system is serviced.

FLUID LEVEL INSPECTION

NOTE:

When the fluid level is low, check the brake pads for wear (see next page). A low fluid level may be due to wear of the brake pads. If the brake pads are worn, the caliper piston is pushed out, and this accounts for a low reservoir level. If the brake pads are not worn and the fluid level is low, check the entire system for leaks (see next page).

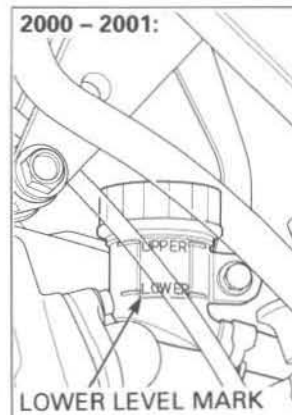

FRONT BRAKE:

Check the front brake fluid reservoir level through the sight glass. If the level is near the lower level mark, check the brake pad wear (page 3-14).

REAR BRAKE:

Place the motorcycle on a level surface, and support it in an upright position. Check the rear brake fluid reservoir level. If the level is near the lower level mark, check the brake pad wear (page 3-14).

FRONT:

Remove the screws, cover and diaphragm. Fill the reservoir with DOT 4 brake fluid to the upper level mark. Install the diaphragm and cover. Tighten the screws to the specified torque.

TORQUE: 1 N·m (0.1 kgf·m, 0.7 lbf·ft)

Check the entire system for leaks.

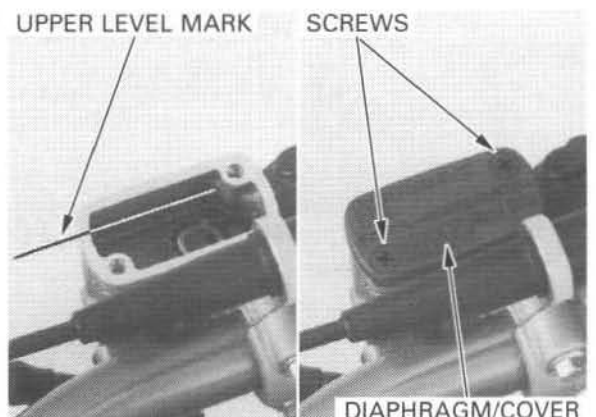

MAINTENANCE

REAR:

- 2000 – 2001:* Remove the fuel tank (page 2-5).
Remove the cap, diaphragm and plate.
Fill the reservoir with DOT 4 brake fluid to the upper level mark.
Install the plate, diaphragm and cap.
Tighten the cap securely.
Install the fuel tank (page 2-5).
- After 2001:* Remove the bolts, cover and diaphragm.
Fill the reservoir with DOT 4 brake fluid to the upper level mark. Install the diaphragm and cover.

NOTE:

Do not bend the diaphragm during installation.

Tighten the bolts to the specified torque.

TORQUE: 1 N·m (0.1 kgf·m, 0.7 lbf·ft)

Check the entire system for leaks.

Inspect the brake hose and fittings for deterioration, cracks or signs of leakage. Tighten any loose fittings.

Replace the hose and fittings as required.

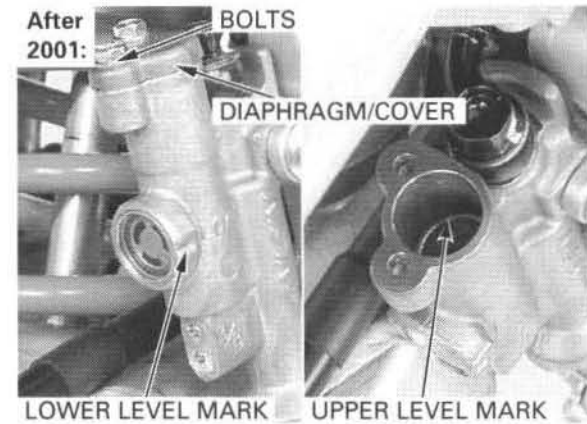
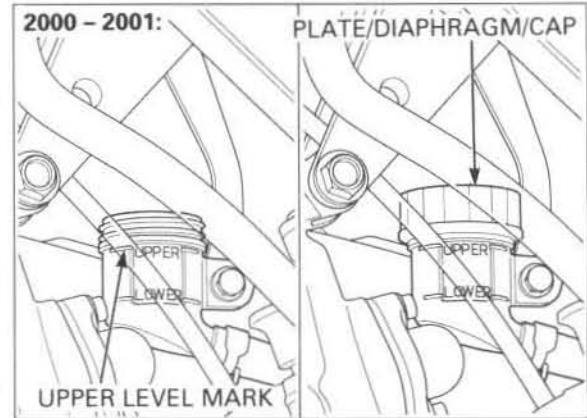

BRAKE PAD WEAR

Check the brake pads for wear.
Replace the brake pads if either pad is worn to the bottom of the wear limit groove.

Refer to page 13-5 for brake pad replacement.

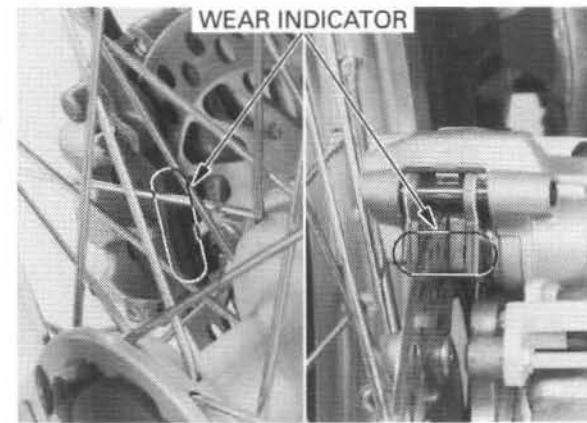

BRAKE SYSTEM

LEVER POSITION INSPECTION

The brake lever position can be adjusted by loosening the lock nut and turning the adjuster.

Turning the adjuster clockwise moves the brake lever farther away from the grip; turning the adjuster counterclockwise moves the brake lever closer to the grip.

After adjustment, hold the adjuster and tighten the lock nut to the specified torque.

TORQUE: 6 N·m (0.6 kgf·m, 4.3 lbf·ft)

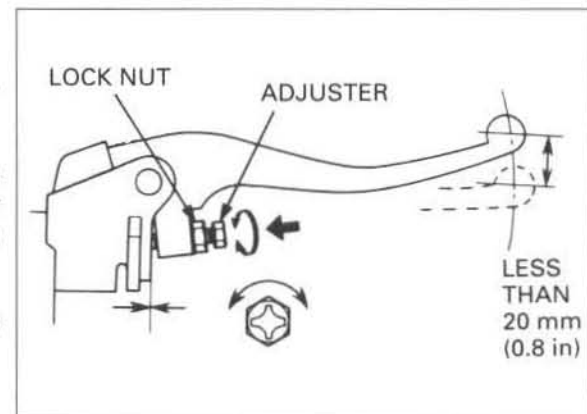

If the brake lever free play exceeds 20 mm (0.8 in), there is air in the system that must be bled. Refer to page 13-4 for brake system bleeding.

NOTE:

Apply grease to the contact faces of the adjuster bolt and piston.

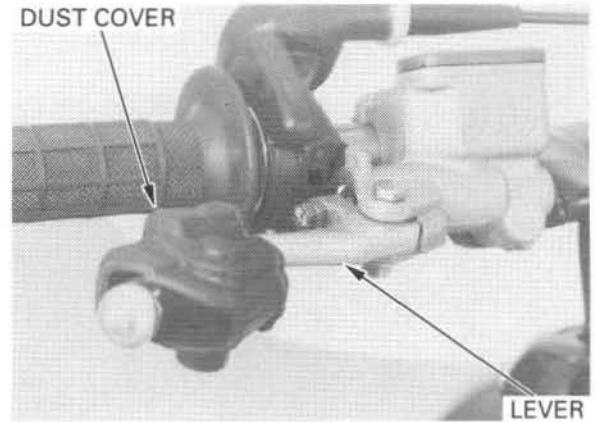

BRAKE PEDAL HEIGHT

Adjust the brake pedal to the desired height by loosening the lock nut and turning the pedal height adjusting bolt. Tighten the lock nut.

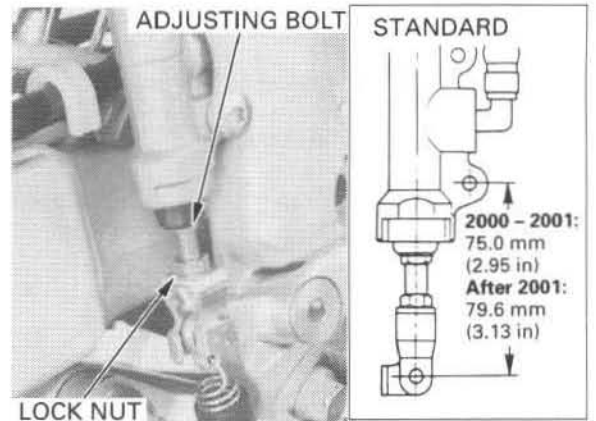

CLUTCH SYSTEM

Measure the clutch free play at lever end.

FREE PLAY: 10 - 20 mm (3/8 - 3/4 in)

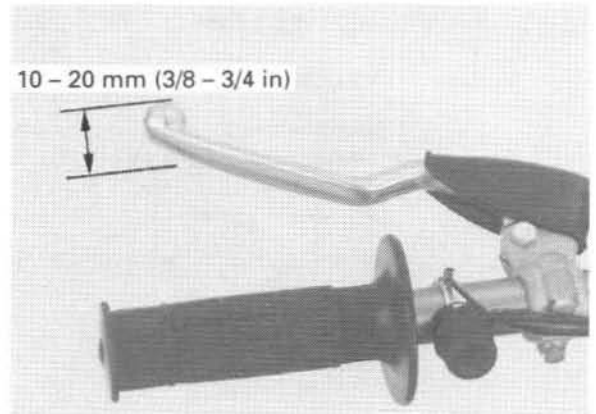

Minor adjustments are made at the adjuster on the lever.

Pull the cover back. Loosen the lock nut and turn the adjuster.

Tighten the lock nut.

If the adjuster is threaded out near its limit and the correct free play cannot be obtained, turn the adjuster all the way in and back out one turn.

Tighten the lock nut, install the dust cover and make a major adjustment, as follows.

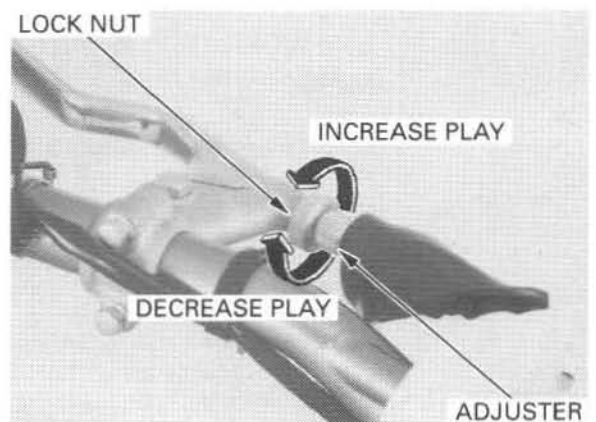

MAINTENANCE

Major adjustments are made with the in line cable adjuster located behind the number plate.

Loosen the lock nut and turn the adjuster.
Tighten the lock nut.

If proper free play cannot be obtained using both procedures or the clutch slips during the test ride, disassemble and inspect the clutch (See section 9).

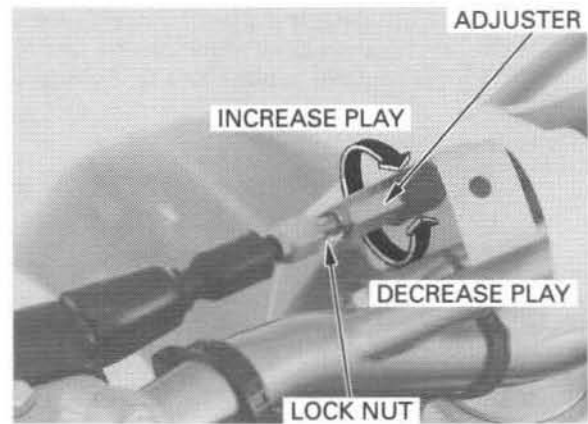

CONTROL CABLES

Remove the throttle housing dust cover.
Remove the throttle cable end cover.
Remove the throttle cable roller and collar.

Disconnect the throttle cable end from the throttle grip.

Disconnect the clutch cable upper end from the clutch lever.

It is not necessary to lubricate the cables.

Thoroughly lubricate the cable pivot points with a commercially available cable lubricant.

If the clutch lever or throttle operation is not smooth, replace the cable.

CAUTION:

Be sure the throttle returns freely from fully open to fully closed automatically, in all steering positions.

Installation is in the reverse order of removal.

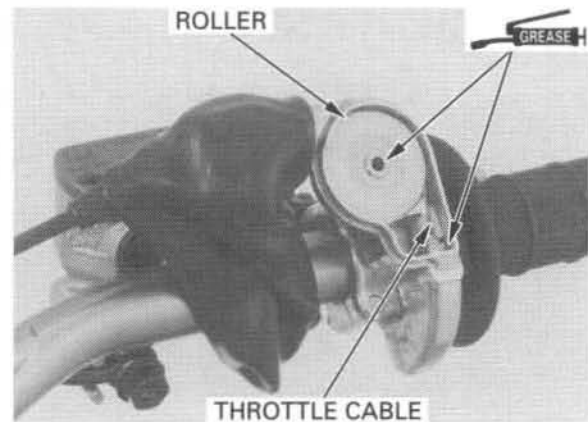
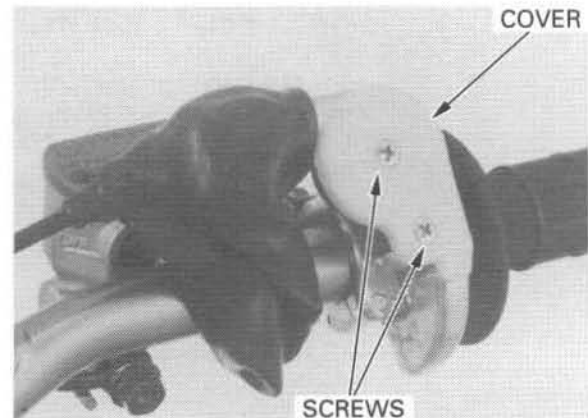

EXPANSION CHAMBER/SILENCER

SILENCER GLASS WOOL REPLACEMENT

Remove the silencer case (page 2-6).

Remove the silencer case bolts.
Pull out the inner pipe.

NOTE:

Hold the mounting tab (after removing collar rubber) of the silencer case gently in a vise protected with a shop towel or soft jaws.

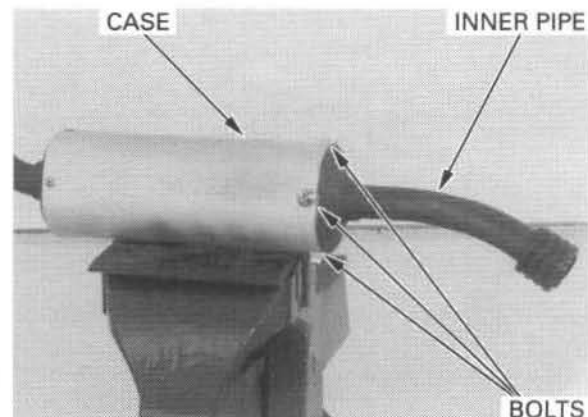

Remove the glass wool packing.

Remove the carbon deposits from the inner pipe using a wire brush.

Be careful not to damage the glass wool packing.

Install the new glass wool packing material.

Apply muffler sealant (high-temperature silicone) in the area shown.

Insert the inner pipe and packing into the silencer case and align the bolt hole.

Install and tighten the silencer case bolts.

Wipe off any excess sealant.

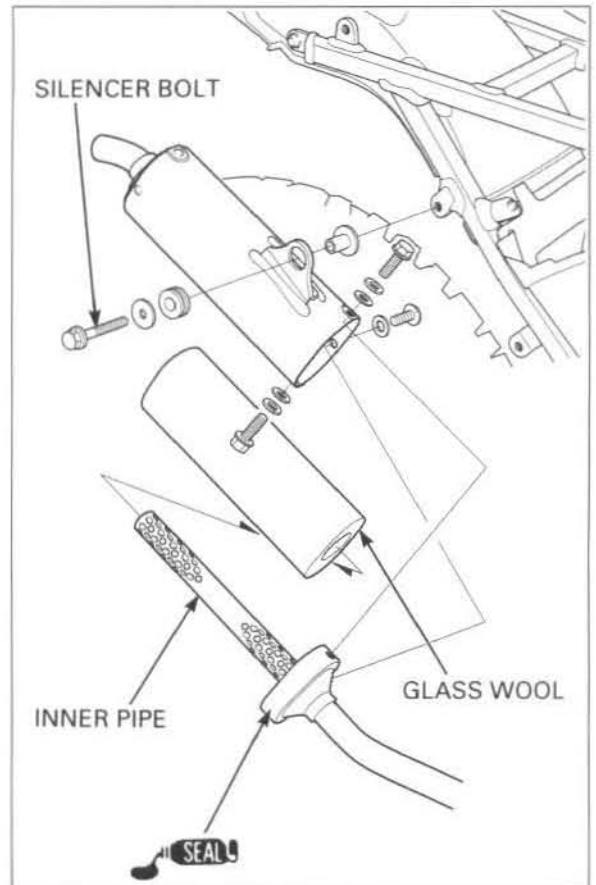

SUSPENSION

FRONT SUSPENSION INSPECTION

Check the action of the forks by operating the front brakes and compressing the front suspension several times.

Check the entire assembly for signs of leaks, damage or loose fasteners.

Make sure that the fork protectors and dust seals are clean and not packed with mud and dirt.

Remove any dirt that has accumulated on the bottom of the fork seals.

Replace damaged components which cannot be repaired.

Tighten all nuts and bolts.

Refer to section 11 for fork service.

Air pressure acts as a progressive spring and affects the entire range of fork travel.

Air is an unstable gas; it increases in pressure as it is worked (such as in a fork), so the fork action on your CR will get stiffer as the race progresses.

Release built-up air-pressure from the fork legs after practice and between heats.

Be sure the fork is fully extended with the front tire off the ground.

Loosen the pressure release screws fully, then tighten them.

TORQUE: 1.2 N·m (0.12 kgf·m, 0.87 lbf·ft)

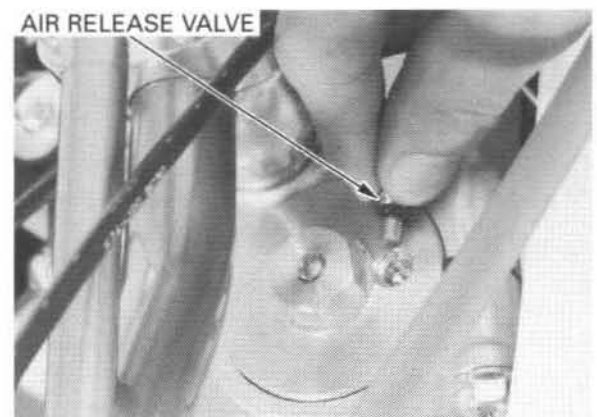

REAR SUSPENSION INSPECTION

Check the action of the shock absorber by compressing it several times.

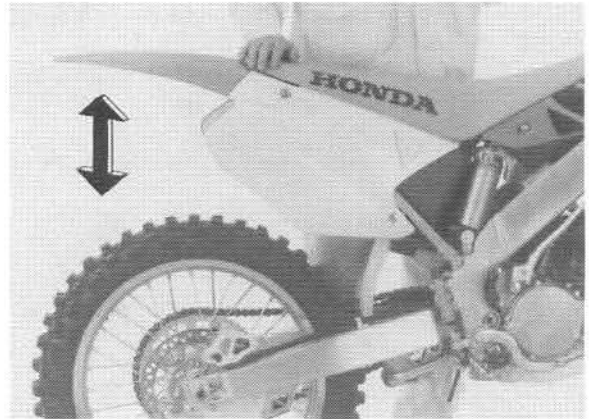

Remove the sub-frame (page 2-4).

Check the entire shock absorber assembly for signs of leaks, damage or loose fasteners. Replace damaged components which cannot be repaired. Tighten all nuts and bolts.

Refer to section 12 for shock absorber service.

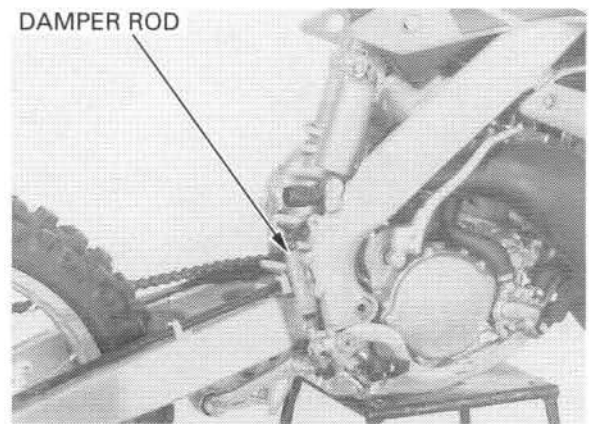

Raise the rear wheel off the ground by placing a workstand under the engine.

Hold the swingarm and move the rear wheel side-ways with force to see if the wheel bearings are worn.

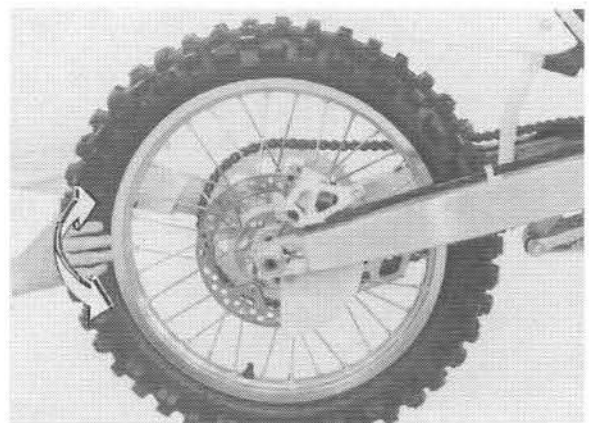

SWINGARM/SHOCK LINKAGE

Raise the rear wheel off the ground by placing a workstand under the engine.

Check for worn swingarm bearings by grabbing the rear swingarm and attempting to move the swingarm side to side.

Replace the bearings if excessively worn (page 12-32).

Check that the shock linkage and needle bearings are not damaged.

Disassemble, clean and inspect the swingarm and shock linkage pivot bearings and related seals every 3 races or after about 7.5 hours of running (page 12-25 through 12-35). Lubricate and reassemble.

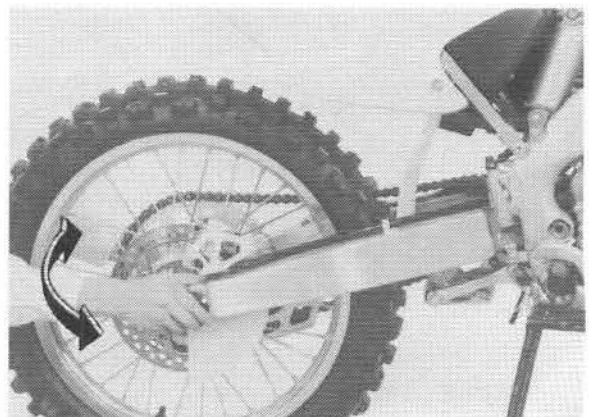

NUTS, BOLTS, FASTENERS

Check that all chassis nuts and bolts are tightened to their correct torque values (page 1-12).

Check that all safety clips, hose clamps and cable stays are in place and properly secured.

WHEELS/TIRES

Tire pressure should be checked when the tires are COLD.

Check the tires for cuts, embedded nails, or other damage.

Check the front and rear wheels for trueness (refer to section 11 and 12).

Check the cold tire pressure.

TIRE PRESSURE (FRONT/REAR):

100 kPa (1.0 kgf/cm², 14 psi)

Inspect the wheel rims and spokes for damage. Tighten any loose spokes and rim locks to the specified torque.

TORQUE: SPOKES: 4 N·m (0.4 kgf·m, 3.0 lbf·ft)

RIM LOCK: 13 N·m (1.3 kgf·m, 9 lbf·ft)

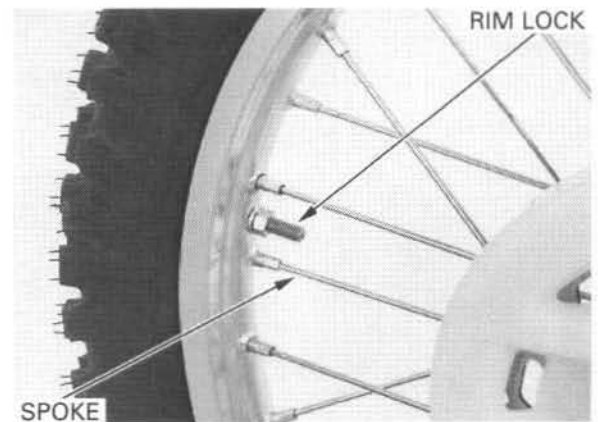
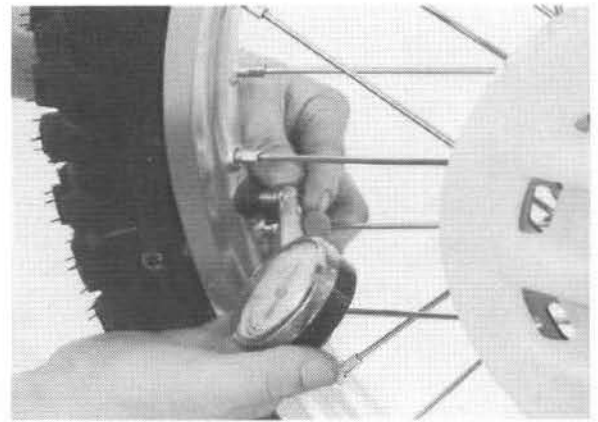

STEERING HEAD BEARINGS

Raise the front wheel off the ground by placing a workstand under the engine.

Be sure that the control cables do not interfere with handlebar rotation.

Check that the handlebar moves freely from side to side.

If the handlebar moves unevenly, binds, or has vertical movement, inspect the steering head bearings (Section 11).

If excessive play has developed, check the steering stem for cracks.



FUEL SYSTEM

2000 - 2001:

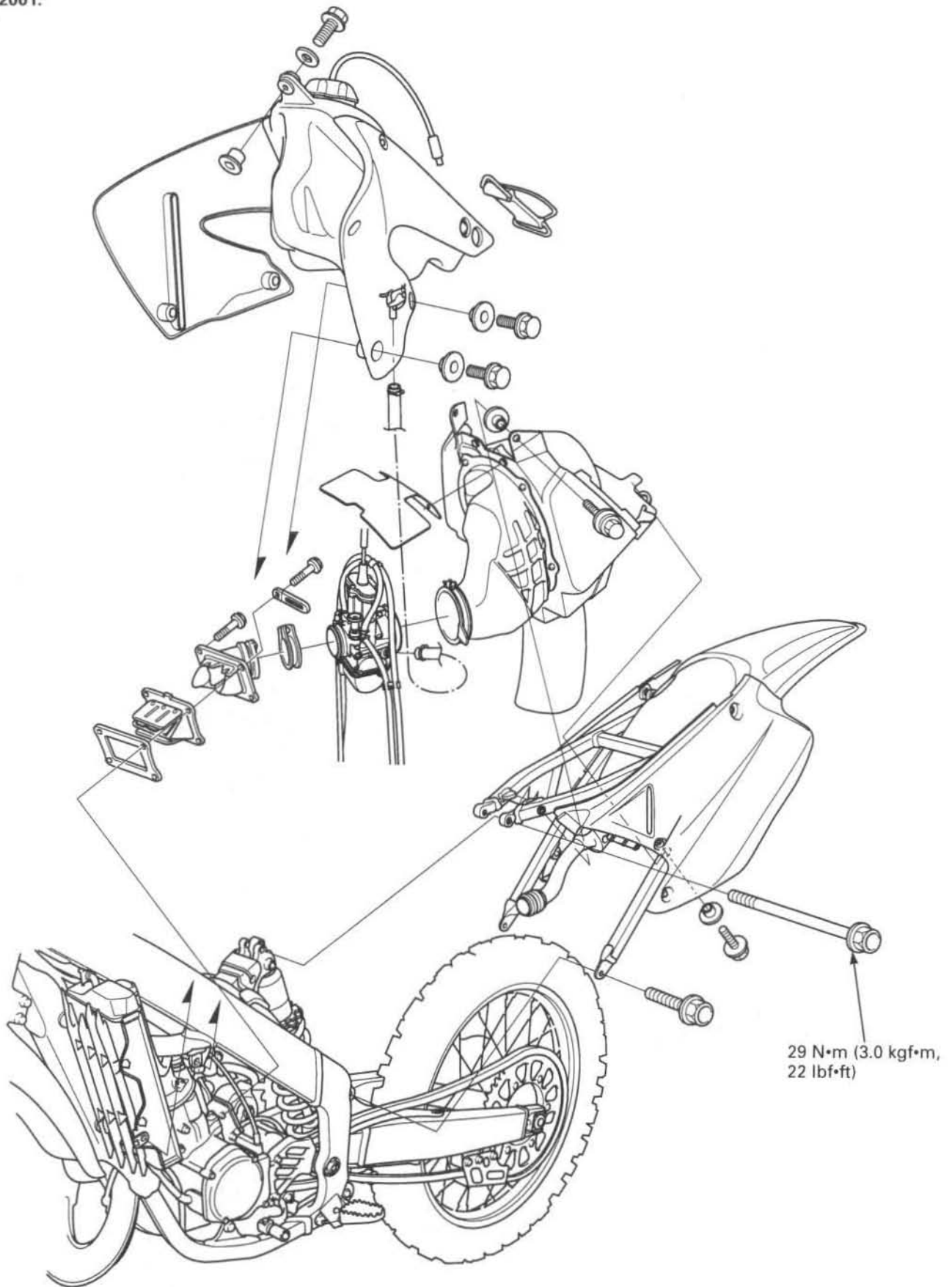

4. FUEL SYSTEM

SERVICE INFORMATION	4-2	CARBURETOR REMOVAL/ DISASSEMBLY	4-9
TROUBLESHOOTING	4-3	CARBURETOR ASSEMBLY/ INSTALLATION	4-14
CARBURETOR ADJUSTMENT, MINOR	4-4	REED VALVE	4-21
CARBURETOR ADJUSTMENT, MAJOR	4-5	AIR CLEANER HOUSING	4-23
TUNING FOR SPECIAL CONDITIONS	4-8		

4

After 2001:

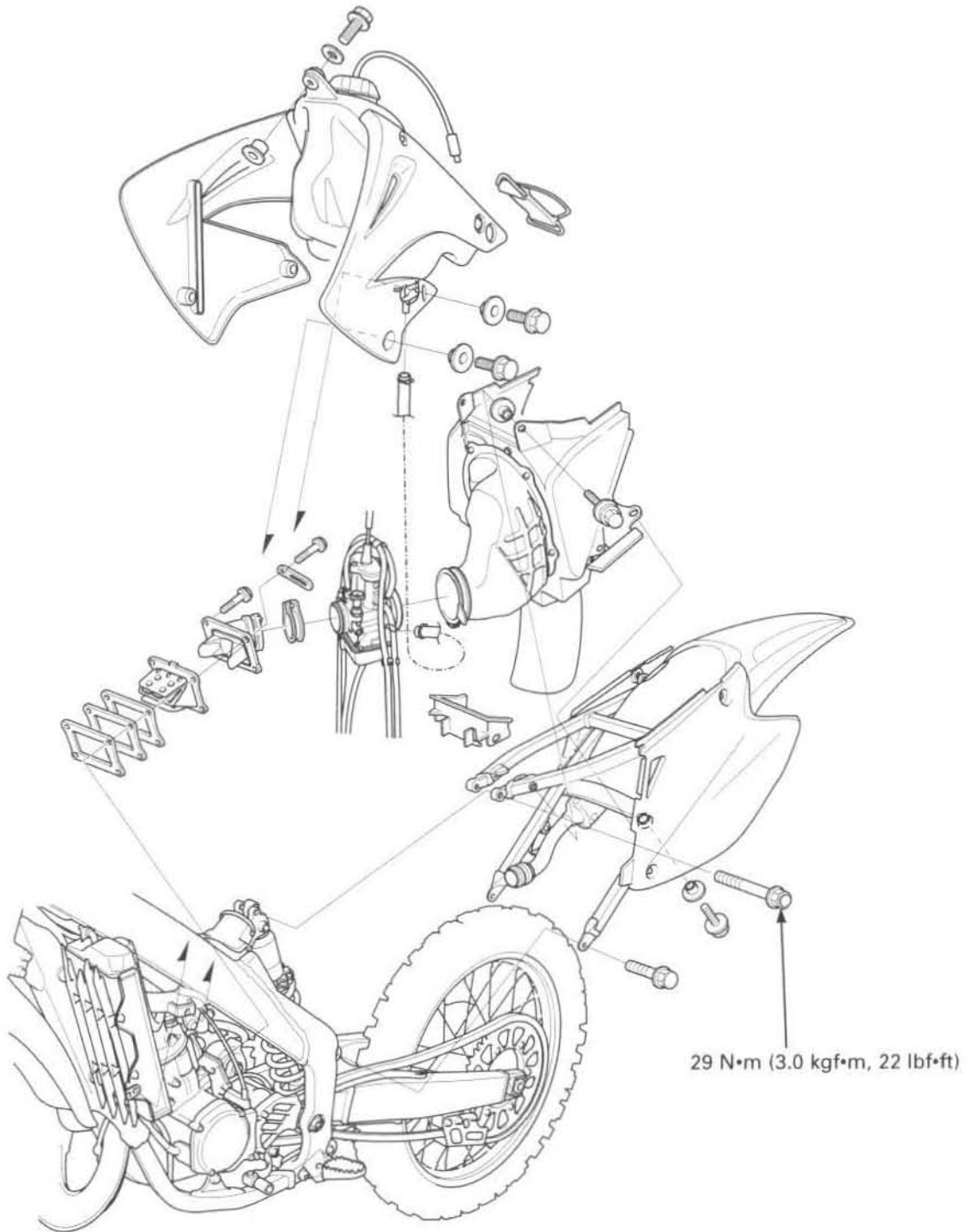

SERVICE INFORMATION

GENERAL

⚠ WARNING

- Gasoline is extremely flammable and is explosive under certain conditions. **KEEP OUT OF REACH OF CHILDREN.**
- Work in a well ventilated area with the engine stopped.
- Do not smoke or allow flames or sparks in the work area or where gasoline is stored.
- Bending or twisting the control cables will impair smooth operation and can cause the cables to stick or bind, resulting in loss of vehicle control.

- Work in a well ventilated area. Smoking or allowing flames or sparks in the work area or where gasoline is stored can cause a fire or explosion.
- Refer to section 2 for fuel tank removal and installation.
- When disassembling fuel system parts, note the location of the O-rings. Replace them with new ones on reassembly.
- Before disassembling the carburetor, place the suitable container under the carburetor drain hose loosen the bolt and drain the carburetor.
- After removing the carburetor, wrap the intake ports of the engine with a shop towel or cover it with piece of tape to prevent any foreign material from dropping into the engine.

NOTE:

If the vehicle is to be stored for more than one month, drain the float bowls. Fuel left in the float bowls may result in clogged jets, resulting in hard starting or poor driveability.

SPECIFICATIONS

ITEM		SPECIFICATIONS
Fuel tank capacity	2000 – 2001:	7.5 liter (2.0 US gal, 1.6 Imp gal)
	After 2001:	7.7 liter (2.0 US gal, 1.7 Imp gal)
Recommended fuel		Automobile gasoline with a pump octane number 92 or higher
Recommended engine oil		Pro-Honda HP2 2-Stroke Oil or equivalent
Fuel/oil mixing ratio		32:1
Carburetor identification number	2000:	TMX01A
	2001:	TMX01B
	After 2001:	TMX02A
Main jet	2000:	#360
	2001:	#380
	After 2001:	#400
Slow jet	2000:	#50
	2001:	#45
	After 2001:	#32.5
Jet needle	2000:	6BEG20 – 69
	2001:	6BEG20 – 68
	After 2001:	6DFY5-74
Jet needle clip position		3rd groove form top
Air screw initial opening	2000:	1-3/4 turns out
	2001:	2-1/4 turns out
	After 2001:	2-1/8 turns out
Float level	2000 – 2001:	15.0 mm (0.59 in)
	After 2001:	7.5 mm (0.30 in)
Throttle grip free play		3 – 5 mm (1/8 – 1/4 in)
Reed valve clearance service limit		0.2 mm (0.01 in)

TORQUE VALUES

Sub-frame mounting bolt (upper)	29 N•m (3.0 kgf•m, 22 lbf•ft)
Reed valve mounting screw	1 N•m (0.1 kgf•m, 0.7 lbf•ft)
Throttle cable holder	3 N•m (0.3 kgf•m, 2.2 lbf•ft)
Float pin set screw	2 N•m (0.2 kgf•m, 1.4 lbf•ft)
Needle jet holder (2000 – 2001:)	3 N•m (0.3 kgf•m, 2.2 lbf•ft)
Main jet	2 N•m (0.2 kgf•m, 1.4 lbf•ft)
Slow jet	1 N•m (0.1 kgf•m, 0.7 lbf•ft)
Float valve seat set screw	1 N•m (0.1 kgf•m, 0.7 lbf•ft)
Carburetor top screw (2000:)	4 N•m (0.4 kgf•m, 3.0 lbf•ft)
(After 2000:)	2 N•m (0.2 kgf•m, 1.4 lbf•ft)
Throttle stop screw lock nut	2 N•m (0.2 kgf•m, 1.4 lbf•ft)
Float chamber screw (2000 – 2001:)	2 N•m (0.2 kgf•m, 1.4 lbf•ft)
(After 2001:)	4 N•m (0.4 kgf•m, 3.0 lbf•ft)
Carburetor drain plug (2000 – 2001:)	7 N•m (0.7 kgf•m, 5.1 lbf•ft)
(After 2001:)	4 N•m (0.4 kgf•m, 3.0 lbf•ft)
Choke knob lock nut	4 N•m (0.4 kgf•m, 3.0 lbf•ft)

TOOL

Carburetor float level gauge	07401 – 0010000
------------------------------	-----------------

TROUBLESHOOTING

Engine won't start

- Too much fuel getting to the engine
 - Air cleaner clogged
 - Flooded carburetors
- Intake air leak
- Fuel contaminated/deteriorated
- No fuel to carburetor
 - Fuel filter clogged
 - Fuel hose clogged
 - Fuel valve stuck
 - Float level misadjusted
 - Fuel tank breather hose clogged
- Slow circuit clogged
- No spark at plug (faulty spark plug or ignition malfunction)

Lean mixture

- Fuel jets clogged
- Fuel tank breather hose clogged
- Fuel filter clogged
- Fuel line restricted
- Float valve faulty
- Float level too low
- Air vent hose clogged
- Advanced ignition timing
- Intake air leak
- Worn crankshaft seal (alternator side)
- Jetting incorrect for altitude/temperature conditions

Rich mixture

- Choke valve in ON position
- Float valve faulty
- Float level too high
- Air jets clogged
- Air cleaner element contaminated
- Flooded carburetor
- Worn crankshaft seal (clutch side)
- Jetting incorrect for altitude/temperature conditions

Engine stalls, hard to start, rough idling

- Fuel line restricted
- Ignition malfunction
- Low cylinder compression
- Fuel mixture too lean/rich
- Fuel contaminated/deteriorated
- Intake air leak
- Float level misadjusted
- Fuel tank breather hose clogged
- Air screw misadjusted
- Slow circuit or starting enrichment circuit clogged

CARBURETOR ADJUSTMENT, MINOR

IDLE MIXTURE AND IDLE SPEED

NOTE:

The standard carburetor settings are ideal for the following conditions: 32-to-1 premix ratio using Pro-Honda HP-2 2-stroke oil or its equivalent, sea level altitude, and 20°C (68° F) air temperature. If your conditions are different, you may need to adjust the carburetor settings using the tuning information chart (page 4-6).

1. Adjust the carburetor setting using the tuning information chart (page 4-6).

STANDARD SETTING:

2000

FLOAT LEVEL: 15.0 mm (0.59 in)
AIR SCREW INITIAL OPENING: 1-3/4 turns out
SLOW JET: #50
MAIN JET: #360
JET NEEDLE: 6BEG20-69
JET NEEDLE CLIP POSITION: 3rd groove from top

2001

FLOAT LEVEL: 15.0 mm (0.59 in)
AIR SCREW INITIAL OPENING: 2-1/4 turns out
SLOW JET: #45
MAIN JET: #380
JET NEEDLE: 6BEG20-68
JET NEEDLE CLIP POSITION: 3rd groove from top

After 2001

FLOAT LEVEL: 7.5 mm (0.30 in)
AIR SCREW INITIAL OPENING: 2-1/8 turns out
SLOW JET: #32.5
MAIN JET: #400
JET NEEDLE: 6DFY5-74
JET NEEDLE CLIP POSITION: 3rd groove from top

2. When the engine is warm enough to run without the choke, push the choke knob down to its off position.
3. Loosen the lock nut and turn the throttle stop screw to obtain the smoothest idle:
 - To decrease idle speed, turn the throttle stop screw counterclockwise.
 - To increase idle speed, turn the throttle stop screw clockwise.
4. Adjust the air screw to obtain the best off-idle performance.
 - If the engine runs rich exiting a corner, turn the air screw counterclockwise to lean the mixture.
 - If the engine runs lean exiting a corner, turn the air screw clockwise to richen the mixture.

CHOKE KNOB



LOCK NUT



THROTTLE STOP SCREW

AIR SCREW

CARBURETOR ADJUSTMENT, MAJOR FOR TEMPERATURE AND ALTITUDE

1. Warm up the engine.
2. Make two or three laps of a course with the standard setting. Note engine acceleration and other engine conditions in relation to throttle opening. Verify the carburetor by removing the spark plug and reading the firing end.
3. Change the carburetor settings or select suitable carburetor jets, taking into consideration the engine conditions and tuning information chart for temperature and altitude (page 4-6).

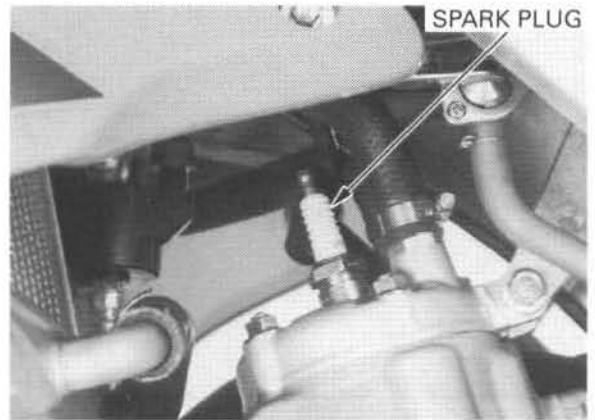
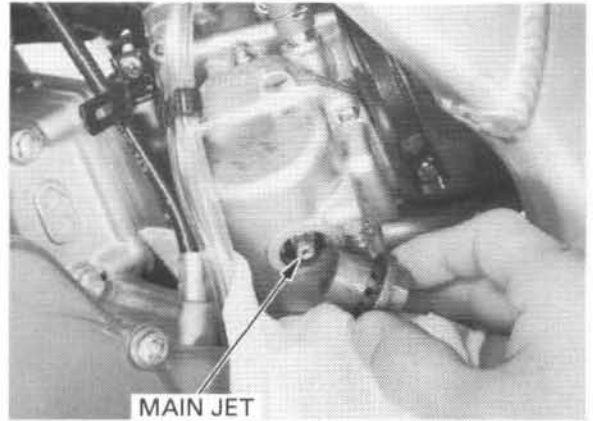

4. Turn the fuel valve OFF, loosen the carburetor insulator clamp screw and connecting tube clamp screw.
5. Drain the gasoline from the carburetor. Remove the screws and float chamber and baffle plate.
6. Change the jets as required and reinstall the float chamber.

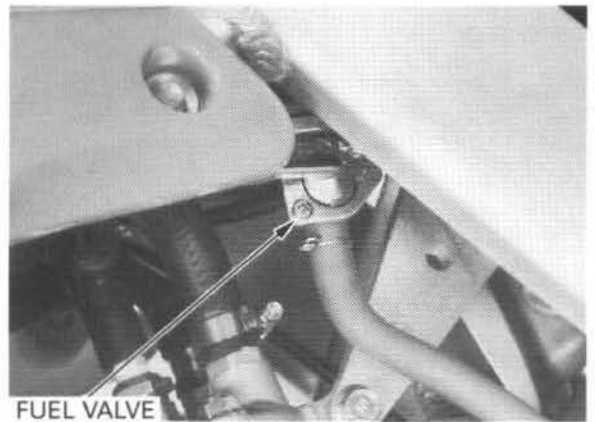

7. Remove the jet needle from the throttle valve (page 4-9) and change the jet needle clip position as required.
8. Reinstall the jet needle and carburetor top (page 4-19).
9. Tighten the carburetor insulator clamp screw and connecting tube clamp screw.
10. Adjust the air screw opening as required.

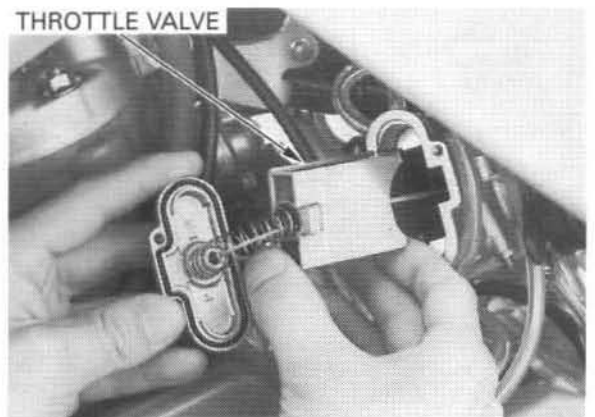

FUEL SYSTEM

TUNING INFORMATION CHART

2000:

Temperature	Cent.	-35° ~ -18°	-17° ~ -7°	-6° ~ 4°	3° ~ 15°	14° ~ 26°	25° ~ 38°	37° ~ 49°
Altitude	Fahr.	-21° ~ 0°	-1° ~ 20°	19° ~ 40°	39° ~ 60°	59° ~ 80°	79° ~ 100°	99° ~ 120°
3,000 m (10,000 ft)	AS: SJ: NC: MJ:	1-3/4 50 3rd 360	2 50 3rd 350	2-1/4 50 3rd 340	2-1/2 50 3rd 330	2-3/4 50 2nd 320	3 50 2nd 310	2-1/2 45 2nd 300
2,300 m (7,500 ft)	AS: SJ: NC: MJ:	1-1/2 50 3rd 370	1-3/4 50 3rd 360	2 50 3rd 350	2-1/4 50 3rd 340	2-1/2 50 2nd 330	2-3/4 50 2nd 320	3 50 2nd 310
2,299 m (7,499 ft)	AS: SJ: NC: MJ:	1-1/2 50 3rd 370	1-3/4 50 3rd 360	2 50 3rd 350	2-1/4 50 3rd 340	2-1/2 50 2nd 330	2-3/4 50 2nd 320	3 50 2nd 310
1,500 m (5,000 ft)	AS: SJ: NC: MJ:	1-1/4 50 4th 390	1-1/2 50 3rd 380	1-3/4 50 3rd 370	2 50 3rd 350	2-1/4 50 3rd 340	2-1/2 50 2nd 330	2-3/4 50 2nd 320
1,499 m (4,999 ft)	AS: SJ: NC: MJ:	1-1/4 50 4th 390	1-1/2 50 3rd 380	1-3/4 50 3rd 370	2 50 3rd 350	2-1/4 50 3rd 340	2-1/2 50 2nd 330	2-3/4 50 2nd 320
750 m (2,500 ft)	AS: SJ: NC: MJ:	1 50 4th 410	1-1/4 50 4th 390	1-1/2 50 3rd 380	1-3/4 50 3rd 360	2 50 3rd 350	2-1/4 50 3rd 340	2-1/2 50 3rd 330
749 m (2,499 ft)	AS: SJ: NC: MJ:	1 50 4th 410	1-1/4 50 4th 390	1-1/2 50 3rd 380	1-3/4 50 3rd 360	2 50 3rd 350	2-1/4 50 3rd 340	2-1/2 50 3rd 330
300 m (1,000 ft)	AS: SJ: NC: MJ:	1-1/2 55 4th 420	1 50 4th 400	1-1/4 50 3rd 390	1-1/2 50 3rd 370	STANDARD 1-3/4 50 3rd 360	JETTING 2 50 3rd 350	2-1/4 50 3rd 340
299 m (999 ft)	AS: SJ: NC: MJ:	1-1/2 55 4th 420	1 50 4th 400	1-1/4 50 3rd 390	1-1/2 50 3rd 370	STANDARD 1-3/4 50 3rd 360	JETTING 2 50 3rd 350	2-1/4 50 3rd 340
Sea level	AS: SJ: NC: MJ:	1-1/2 55 4th 420	1 50 4th 400	1-1/4 50 3rd 390	1-1/2 50 3rd 370	STANDARD 1-3/4 50 3rd 360	JETTING 2 50 3rd 350	2-1/4 50 3rd 340

2001:

Temperature	Cent.	-30° ~ -17°	-18° ~ -6°	-7° ~ 5°	4° ~ 16°	15° ~ 27°	25° ~ 38°	37° ~ 49°
Altitude	Fahr.	-21° ~ 0°	-1° ~ 20°	19° ~ 40°	39° ~ 60°	59° ~ 80°	79° ~ 100°	98° ~ 120°
3,000 m (10,000 ft)	AS: SJ: NC: JN: MJ:	2-1/4 45 3rd 6BEG20-68 380	2-1/2 45 3rd 6BEG20-68 370	2-3/4 45 3rd 6BEG20-68 360	3 45 2nd 6BEG21-68 350	2-1/2 40 2nd 6BEG21-68 340	2-3/4 40 2nd 6BEG20-68 330	3 40 2nd 6BEG20-68 320
2,300 m (7,500 ft)	AS: SJ: NC: JN: MJ:	2 45 3rd 6BEG21-68 390	2-1/4 45 3rd 6BEG20-68 380	2-1/2 45 3rd 6BEG20-68 370	2-3/4 45 2nd 6BEG21-68 360	3 45 2nd 6BEG21-68 350	2-1/2 40 2nd 6BEG20-68 340	2-3/4 40 2nd 6BEG20-68 330
2,299 m (7,499 ft)	AS: SJ: NC: JN: MJ:	2 45 3rd 6BEG21-68 390	2-1/4 45 3rd 6BEG20-68 380	2-1/2 45 3rd 6BEG20-68 370	2-3/4 45 2nd 6BEG21-68 360	3 45 2nd 6BEG21-68 350	2-1/2 40 2nd 6BEG20-68 340	2-3/4 40 2nd 6BEG20-68 330
1,500 m (5,000 ft)	AS: SJ: NC: JN: MJ:	1-3/4 45 3rd 6BEG21-68 410	2 45 3rd 6BEG21-68 400	2-1/4 45 3rd 6BEG20-68 390	2-1/2 45 3rd 6BEG20-68 370	2-3/4 45 2nd 6BEG21-68 360	3 45 2nd 6BEG21-68 350	2-1/2 40 2nd 6BEG21-68 340
1,499 m (4,999 ft)	AS: SJ: NC: JN: MJ:	1-3/4 45 3rd 6BEG21-68 410	2 45 3rd 6BEG21-68 400	2-1/4 45 3rd 6BEG20-68 390	2-1/2 45 3rd 6BEG20-68 370	2-3/4 45 2nd 6BEG21-68 360	3 45 2nd 6BEG21-68 350	2-1/2 40 2nd 6BEG21-68 340
750 m (2,500 ft)	AS: SJ: NC: JN: MJ:	1-1/2 45 4th 6BEG20-68 420	1-3/4 45 3rd 6BEG21-68 410	2 45 3rd 6BEG21-68 400	2-1/4 45 3rd 6BEG20-68 380	2-1/2 45 3rd 6BEG20-68 370	2-3/4 45 2nd 6BEG21-68 360	3 45 2nd 6BEG21-68 350
749 m (2,499 ft)	AS: SJ: NC: JN: MJ:	1-1/2 45 4th 6BEG20-68 420	1-3/4 45 3rd 6BEG21-68 410	2 45 3rd 6BEG21-68 400	2-1/4 45 3rd 6BEG20-68 380	2-1/2 45 3rd 6BEG20-68 370	2-3/4 45 2nd 6BEG21-68 360	3 45 2nd 6BEG21-68 350
300 m (1,000 ft)	AS: SJ: NC: JN: MJ:	1-1/4 45 4th 6BEG20-68 430	1-1/2 45 3rd 6BEG21-68 420	1-3/4 45 3rd 6BEG21-68 410	2 45 3rd 6BEG20-68 390	STANDARD 2-1/4 45 3rd 6BEG20-68 380	JETTING 2-1/2 45 3rd 6BEG20-68 370	2-3/4 45 2nd 6BEG21-68 360
299 m (999 ft)	AS: SJ: NC: JN: MJ:	1-1/4 45 4th 6BEG20-68 430	1-1/2 45 3rd 6BEG21-68 420	1-3/4 45 3rd 6BEG21-68 410	2 45 3rd 6BEG20-68 390	STANDARD 2-1/4 45 3rd 6BEG20-68 380	JETTING 2-1/2 45 3rd 6BEG20-68 370	2-3/4 45 2nd 6BEG21-68 360
Sea level	AS: SJ: NC: JN: MJ:	1-1/4 45 4th 6BEG20-68 430	1-1/2 45 3rd 6BEG21-68 420	1-3/4 45 3rd 6BEG21-68 410	2 45 3rd 6BEG20-68 390	STANDARD 2-1/4 45 3rd 6BEG20-68 380	JETTING 2-1/2 45 3rd 6BEG20-68 370	2-3/4 45 2nd 6BEG21-68 360

After 2001:

Temperature Altitude	Cent.	-30° ~ -17°	-18° ~ -6°	-7° ~ 5°	4° ~ 16°	15° ~ 27°	26° ~ 38°	37° ~ 49°
	Fahr.	-21° ~ 0°	-1° ~ 20°	19° ~ 40°	39° ~ 60°	59° ~ 80°	79° ~ 100°	99° ~ 120°
3,050 m (10,000 ft)	AS:	2	2 1/4	2 1/2	2 3/4	2 1/4	2 1/2	2 3/4
	SJ:	32.5	32.5	32.5	32.5	27.5	27.5	27.5
	NC:	3rd	3rd	3rd	2nd	2nd	2nd	2nd
2,300 m (7,500 ft)	JN:	6DFY5-74	6DFY5-74	6DFY5-74	6DFY6-74	6DFY6-74	6DFY5-74	6DFY5-74
	MJ:	400	390	380	370	360	350	340
2,299 m (7,499 ft)	AS:	1 3/4	2	2 1/4	2 1/2	2 3/4	2 1/4	2 1/2
	SJ:	32.5	32.5	32.5	32.5	32.5	27.5	27.5
	NC:	3rd	3rd	3rd	2nd	2nd	2nd	2nd
1,500 m (5,000 ft)	JN:	6DFY6-74	6DFY5-74	6DFY5-74	6DFY6-74	6DFY6-74	6DFY5-74	6DFY5-74
	MJ:	410	400	390	380	370	360	350
1,499 m (4,999 ft)	AS:	1 1/2	1 3/4	2	2 1/4	2 1/2	2 3/4	2 1/4
	SJ:	32.5	32.5	32.5	32.5	32.5	32.5	27.5
	NC:	3rd	3rd	3rd	3rd	2nd	2nd	2nd
750 m (2,500 ft)	JN:	6DFY6-74	6DFY6-74	6DFY5-74	6DFY5-74	6DFY6-74	6DFY6-74	6DFY6-74
	MJ:	430	420	410	390	380	370	360
749 m (2,499 ft)	AS:	1 1/4	1 1/2	1 3/4	2	2 1/4	2 1/2	2 3/4
	SJ:	35	32.5	32.5	32.5	32.5	32.5	32.5
	NC:	4th	3rd	3rd	3rd	3rd	2nd	2nd
300 m (1,000 ft)	JN:	6DFY5-74	6DFY6-74	6DFY6-74	6DFY5-74	6DFY5-74	6DFY6-74	6DFY6-74
	MJ:	440	430	420	400	390	380	370
299 m (999 ft)	AS:	1	1 1/4	1 1/2	1 3/4	2 1/8	2 1/4	2 1/2
	SJ:	37.5	35	32.5	32.5	32.5	32.5	32.5
	NC:	4th	3rd	3rd	3rd	3rd	3rd	2nd
0 m Sea level	JN:	6DFY5-74	6DFY6-74	6DFY6-74	6DFY5-74	6DFY5-74	6DFY5-74	6DFY6-74
	MJ:	450	440	430	410	400	390	380

NOTE:

- If you use the chart correctly, it shouldn't be necessary to adjust more than one jet size richer or leaner to fine tune your CR. If a very large adjustment is required, there may be something wrong elsewhere. Check for worn crankshaft seals, air leaks, blocked exhaust or fuel system, or dirty air cleaner element.
- The tuning information chart will get you very close to the ideal setting. However, because of differences in pressure and humidity, you may need to fine tune the carburetor for race day condition.

• Just off idle:

Engine stumbles (rich): turn out the air screw 1/4 turn.
 Engine surges (lean): turn in the air screw 1/4 turn.

NOTE:

The minimum to maximum range of air screw adjustment is 1 to 3 turns out from the lightly seated position. If you exceed 3 turns out, the next smaller slow jet is needed. If you are under 1 turn out, the next larger slow jet is needed.

• On the top end:

Engine stumbles (rich): go to next smaller main jet.
 Engine surges (lean): go to next large main jet.

CAUTION:

To prevent engine damage, always adjust the main jet (top end) before adjusting the jet needle (mid-range).

• In the mid-range:

Engine stumbles (rich): lower the jet needle by raising the needle clip one position.
 Engine surges (lean): raise the jet needle by lowering the needle clip one position.

TUNING FOR SPECIAL CONDITIONS

Once you've adjusted the carburetor for temperature and altitude, it shouldn't need major readjustment unless the race conditions change drastically. Exclusive of the tuning information chart, there are some unique atmospheric conditions that may require additional adjustments. They are as follows:

Main Jet:

- Go richer on the main jet, by one number, when the track has a very long straightaway, steep climbs, a high percentage of sand, or the track is muddy.
- Go leaner on the main jet, by one number, when it is very humid or raining, or it is very hot (above 45°C (113°F)).

Jet Needles:

- Under normal circumstances, the standard jet needle can be adjusted to fit most situations. However, a peculiar condition may require replacement of the standard jet needle. But before replacing the standard needle, complete all the carburetor adjustments (page 4-3 through 6). If mid-range performance is still not satisfactory, try one of the optional jet needles. See page 1-26.

CARBURETOR REMOVAL/DISASSEMBLY

REMOVAL

Disconnect the fuel hose.
Turn the handlebar to the left fully.

2000 – 2001: Loosen the carburetor insulator band screw and connecting hose band screw, and lean the carburetor to the left.

After 2001: Remove the sub-frame (page 2-4).
Loosen the carburetor insulator band.

Remove the screws and carburetor top, then pull out the throttle valve.

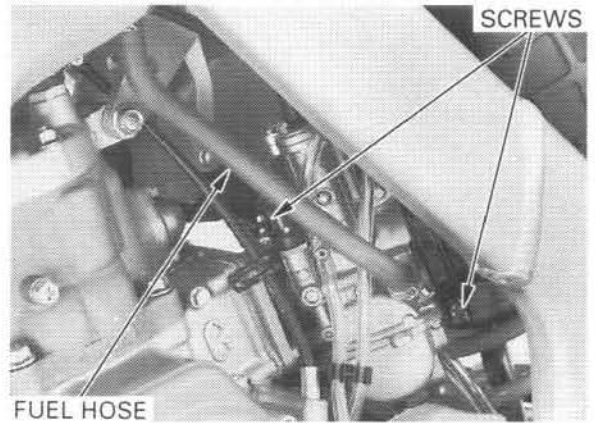

2000 – 2001 Shown:
CARBURETOR TOP

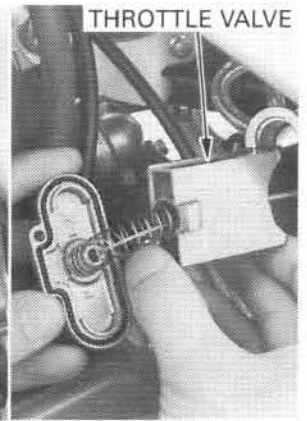
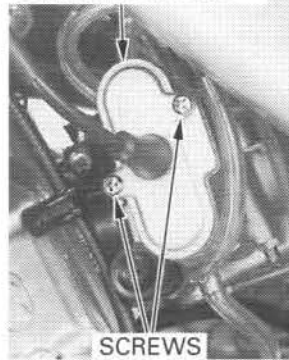

After 2001 Shown:
CARBURETOR TOP

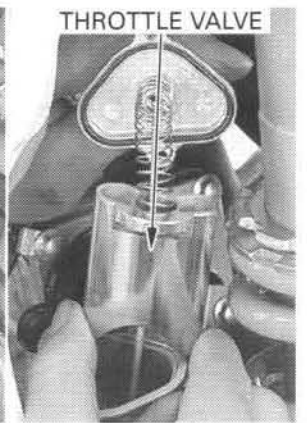
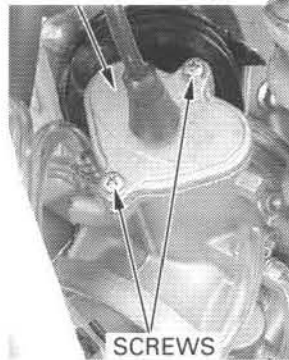

DISASSEMBLY

Compress the spring and remove the collar from the throttle valve.
Compress the spring and remove the throttle cable from the cable holder.

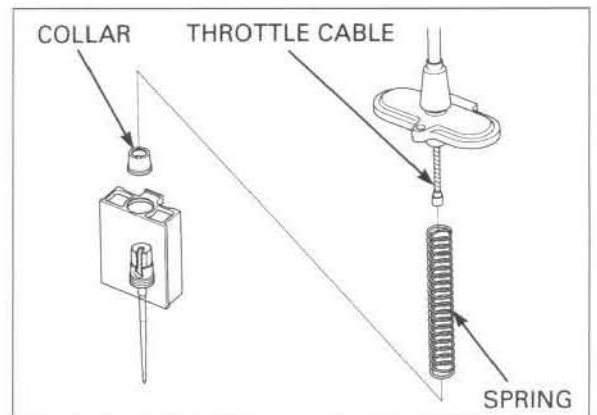

FUEL SYSTEM

Remove the throttle cable holder and jet needle from the throttle valve.

Check the jet needle for stepped wear or damage. Check the throttle valve for damage.

Replace these parts if necessary.

2000 – 2001 Shown:
THROTTLE VALVE

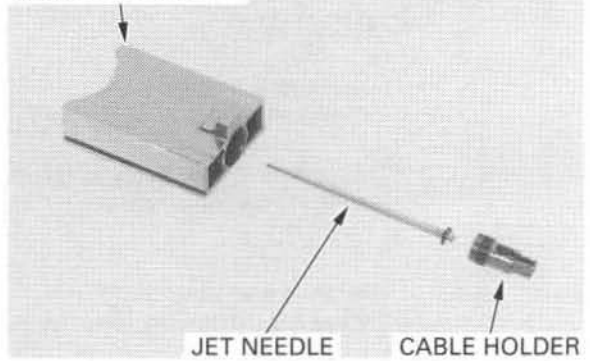

After 2001 Shown:
THROTTLE VALVE

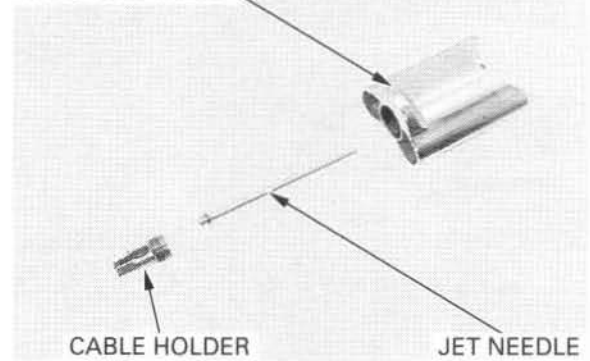

Disconnect the air vent hoses and over flow hose.

2000 – 2001 Shown:

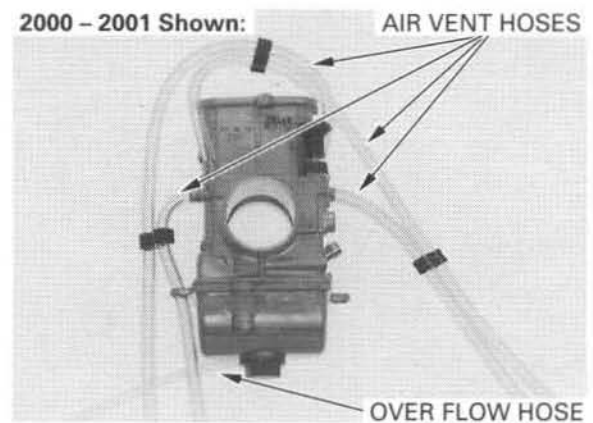

After 2001 Shown:

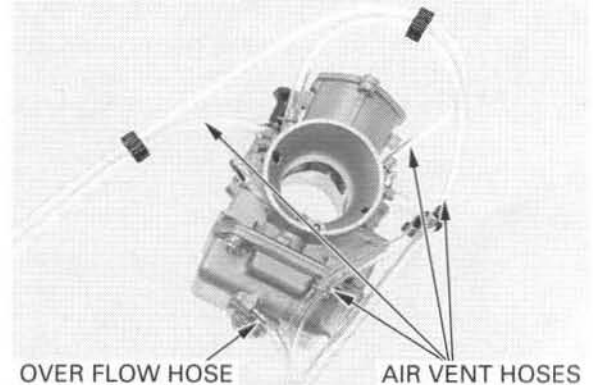

2001 – 2001: Remove the carburetor drain plug and screw.
Remove the float chamber and O-ring.

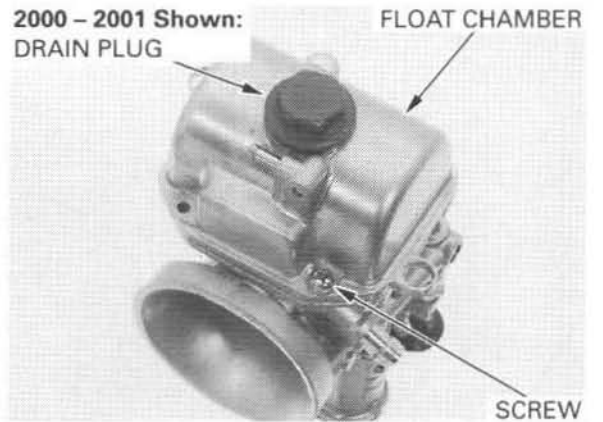

After 2001: Remove the screws, float chamber and O-ring.
Remove the baffle plate.

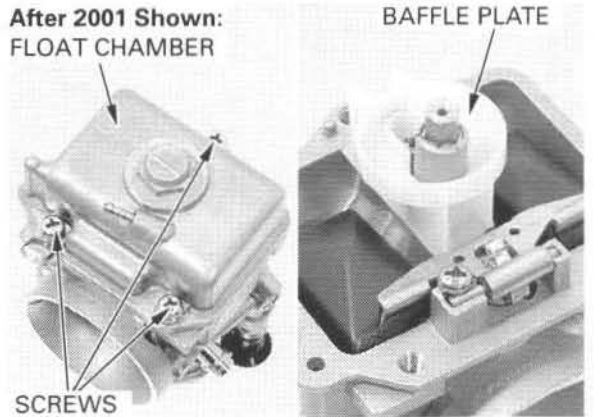

Remove the float pin set screw and float pin.
Remove the float and float valve.

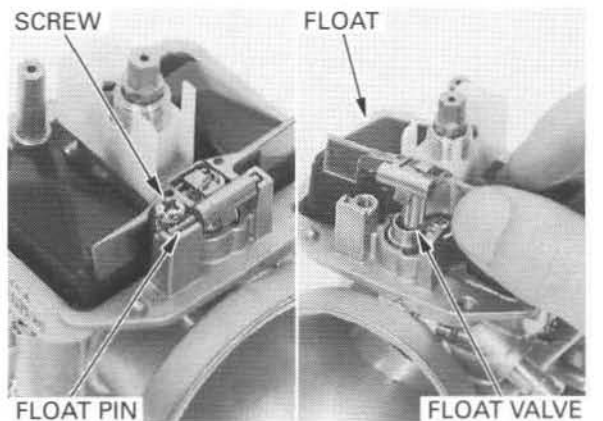

A worn or contaminated valve does not seat properly and will eventually flood the carburetor.

Remove the valve seat set screw and valve seat.
Check the float for damage.
Check the float valve and valve seat for scoring scratches, clogs or damage.
Check the valve seat O-ring for wear or damage.
Check the tip of the float valve where it contacts the valve seat, for stepped wear or contamination.
Replace or clean these parts if necessary.



FUEL SYSTEM

2000 – 2001: Remove the baffle plate, main jet, needle jet holder and slow jet.

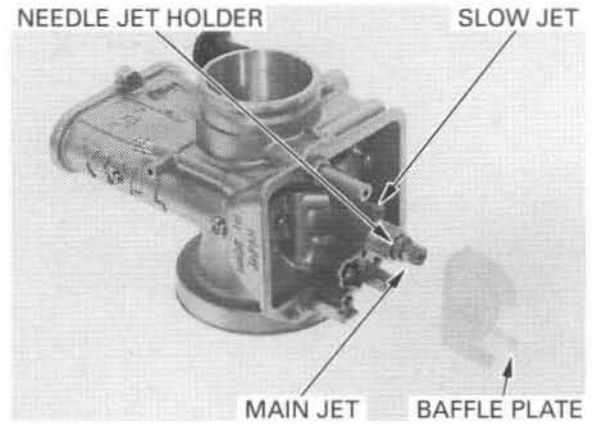

After 2001: Remove the main jet and slow jet.

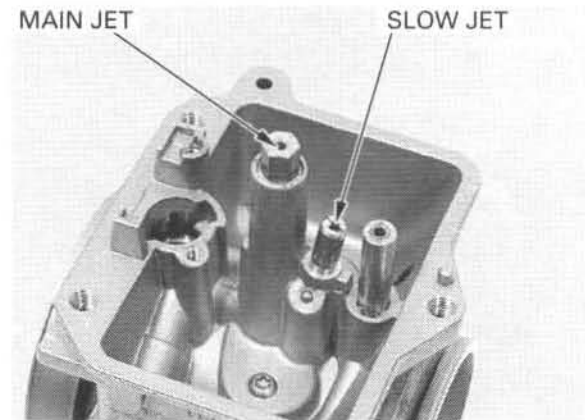

NOTE:

Before removing the air screw, record the number of turns in until it seats lightly, so it can be returned to its original position.

Remove the air screw and throttle stop screw.

2000 – 2001 Shown:



After 2001 Shown:



Check each jet for wear or damage.
Clean the jets with non-flammable or high flash solvent and blow open with compressed air.

Check the air screw for stepped wear or damage.
Check the spring for damage.
Replace these parts if necessary.

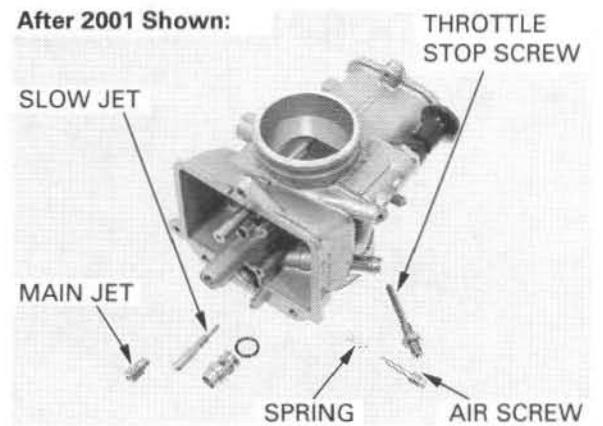
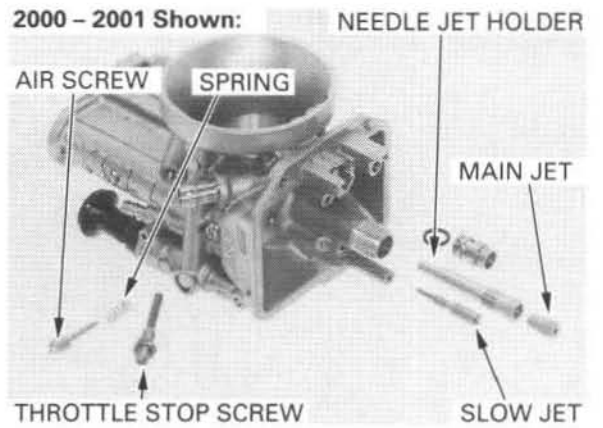

Unscrew the lock nut and remove the choke knob.

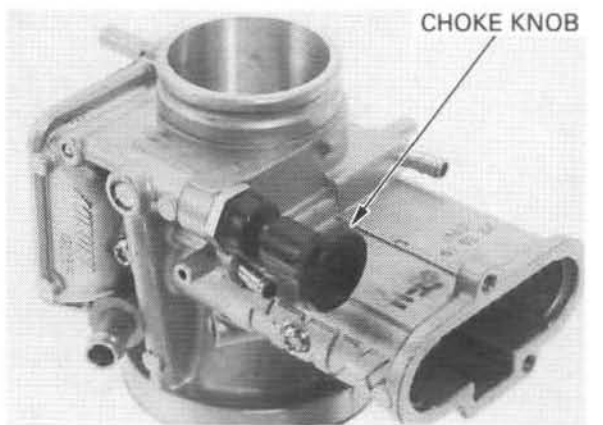

Check the valve seat for damage or stepped wear.
Check the O-ring for damage.



FUEL SYSTEM

CAUTION:

Cleaning the air and fuel passage with a piece of wire will damage the carburetor body.

Blow open all air and fuel passages in the carburetor body with compressed air.

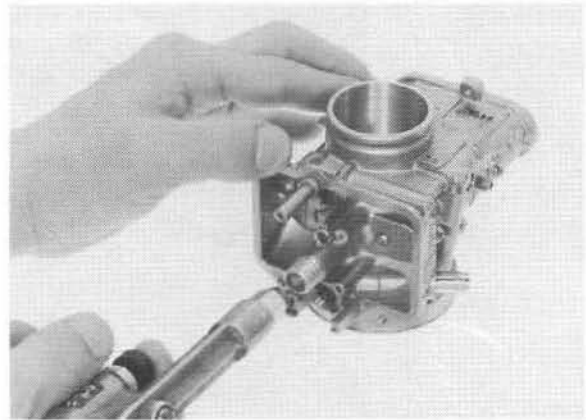

CARBURETOR ASSEMBLY/INSTALLATION

2000 - 2001:

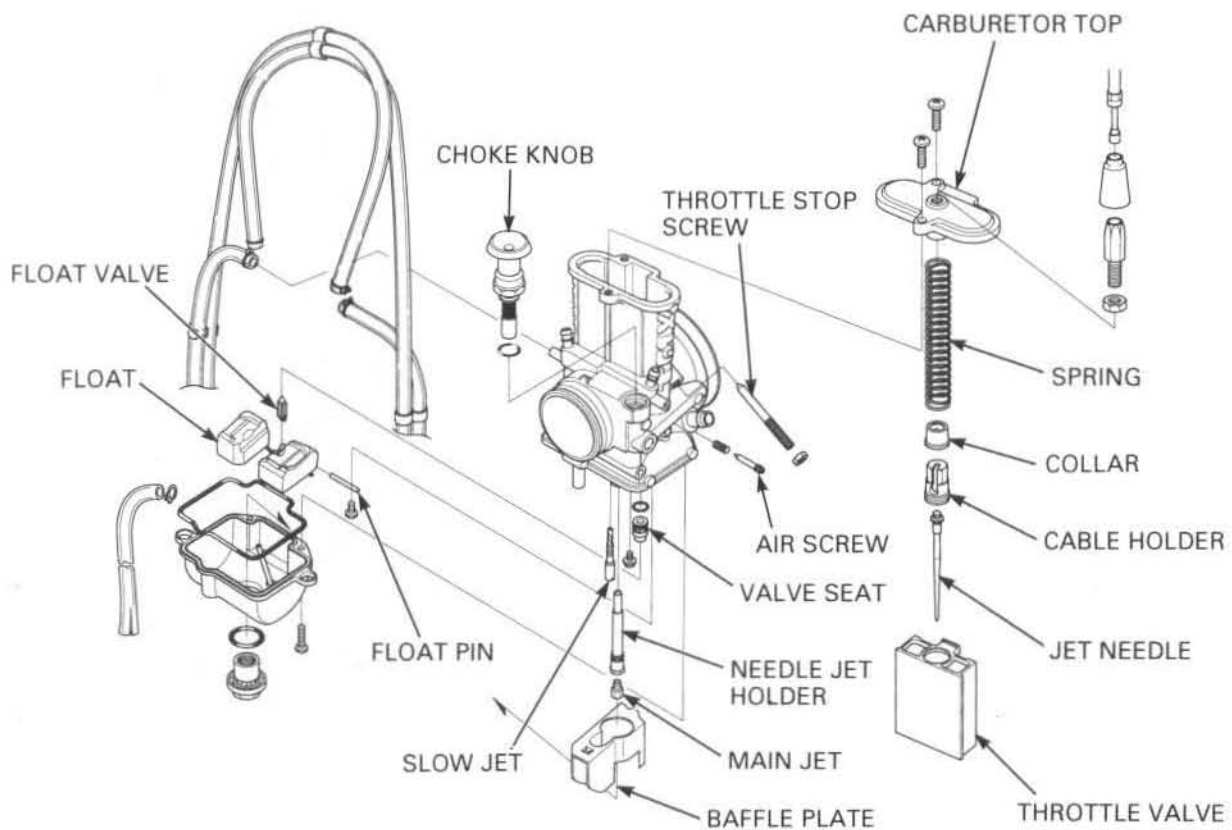

After 2001:

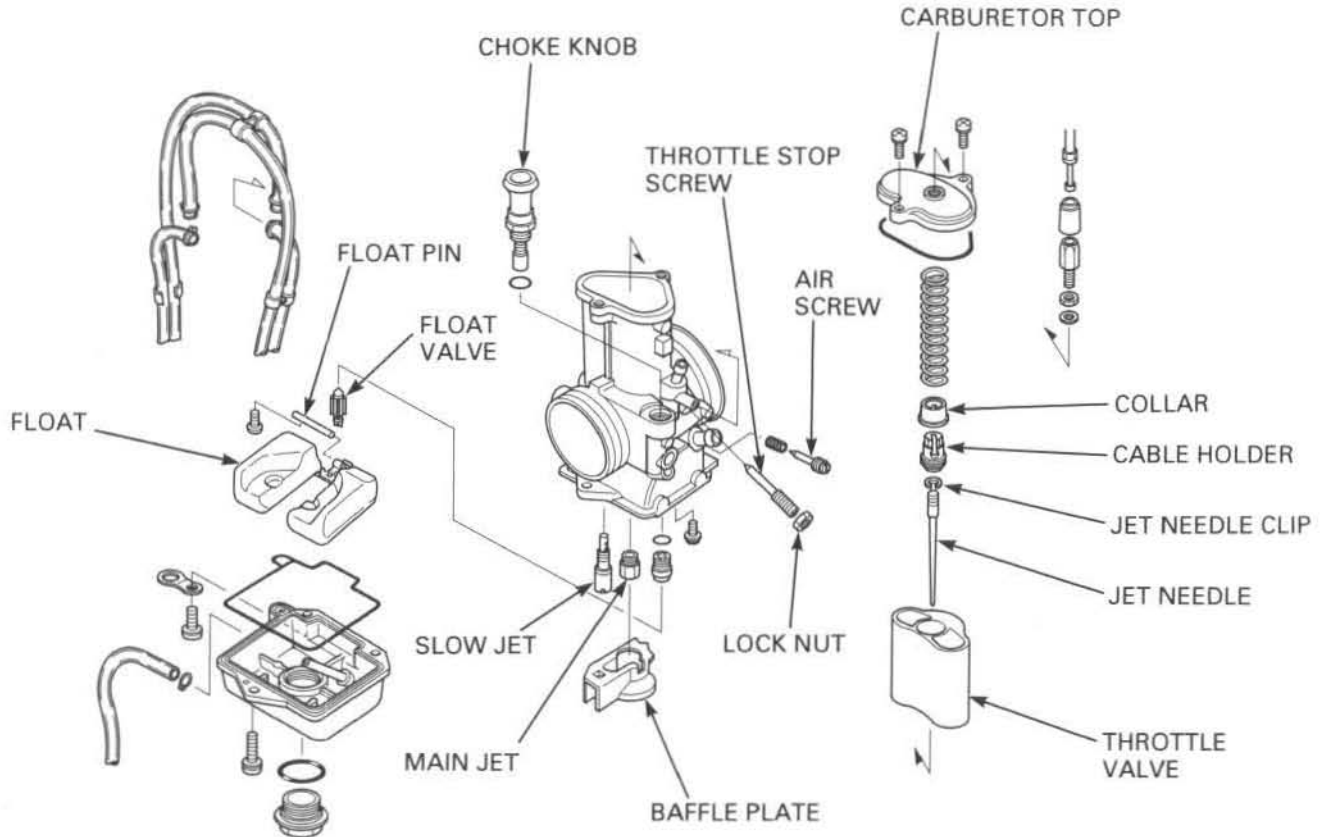

ASSEMBLY

Install the choke knob and tighten the lock nut to the specified torque.

TORQUE: 4 N·m (0.4 kgf·m, 2.9 lbf·ft)

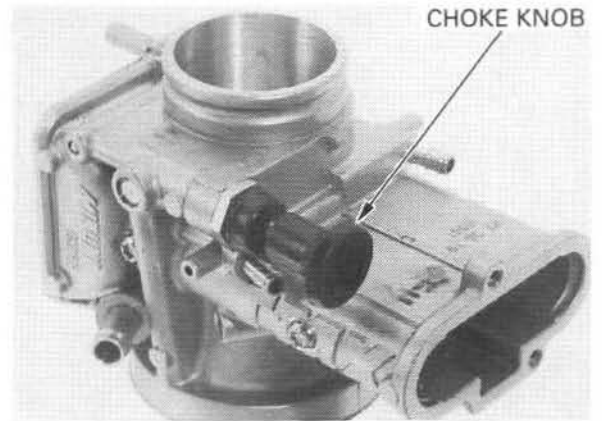

2000 – 2001: Install the air screw, air screw spring, throttle stop screw and lock nut.

NOTE:

Install the air screw and return it to its original position as noted during removal.

2000 – 2001 Shown:



After 2001 Shown:



2000 – 2001: Install the slow jet, needle jet holder, main jet and baffle plate.

TORQUE:

- SLOW JET: 1 N•m (0.1 kgf•m, 0.7 lbf•ft)
- NEEDLE JET HOLDER: 3 N•m (0.3 kgf•m, 2.2 lbf•ft)
- MAIN JET: 2 N•m (0.2 kgf•m, 1.4 lbf•ft)

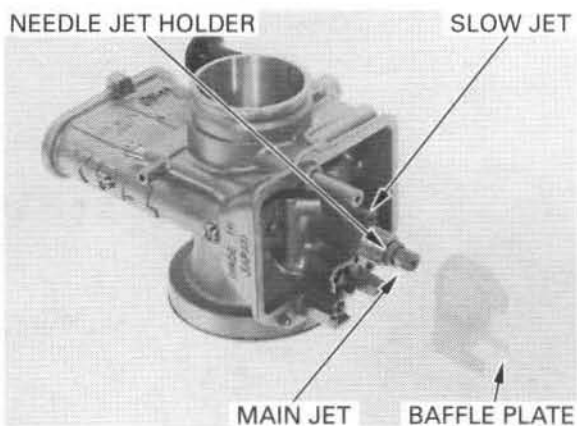

After 2001: Install the slow jet and main jet.

TORQUE:

- SLOW JET: 1 N•m (0.1 kgf•m, 0.7 lbf•ft)
- MAIN JET: 2 N•m (0.2 kgf•m, 1.4 lbf•ft)

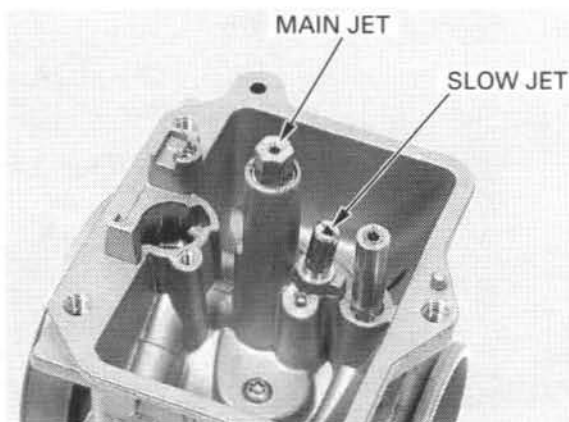

Install the float valve seat and O-ring.
Tighten the screw to the specified torque.

TORQUE: 1 N•m (0.1 kgf•m, 0.7 lbf•ft)

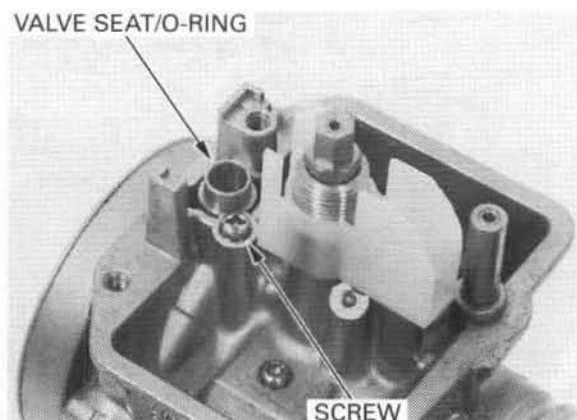

Install the float valve, float and float pin.
Tighten the screw to the specified torque.

TORQUE: 2 N·m (0.2 kgf·m, 1.4 lbf·ft)

NOTE:

- Check the float level after checking the float valve and float.
- Set the float level gauge so that it is perpendicular to the float chamber face and in line with the main jet.

Set the carburetor so that the float valve just contacts the float arm lip. Be sure that the float valve tip is securely in contact with the valve seat. Make sure the float level with the float level gauge.

TOOL:

Carburetor float level gauge 07401-0010000

FLOAT LEVEL:

- 2000 – 2001: 15.0 mm (0.59 in)
- After 2001: 7.5 mm (0.30 in)

If the level is out of specification, adjust the float level by bending the lip.

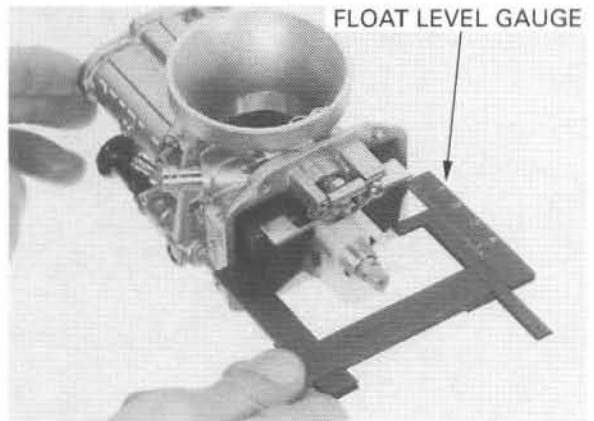
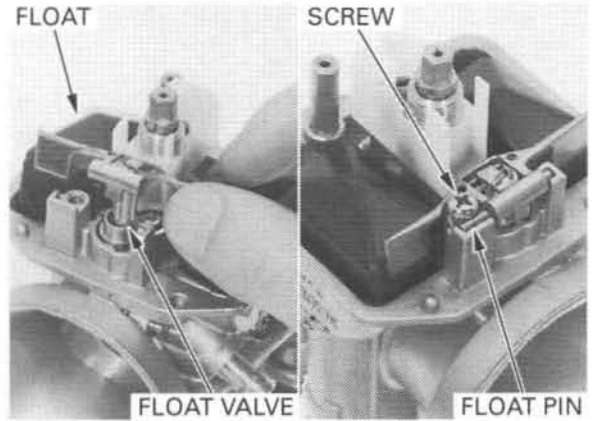

After 2001: Install the baffle plate.

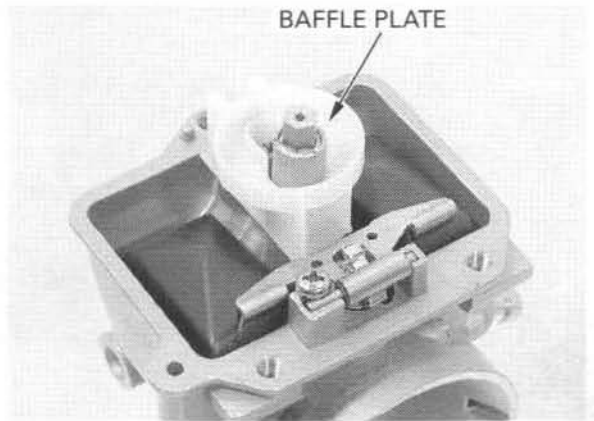

Install a new O-ring to the float chamber.
Install the float chamber to the carburetor.

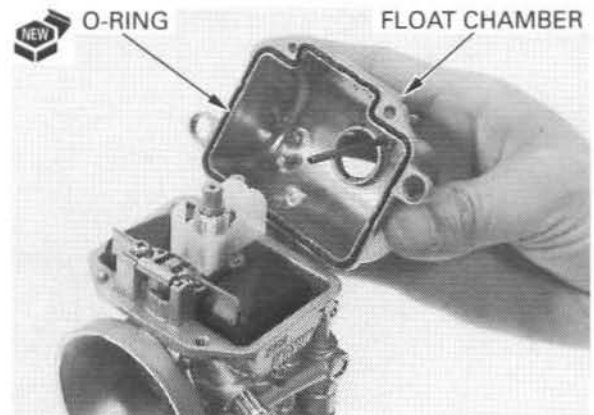

FUEL SYSTEM

Install and tighten the screw to the specified torque.

TORQUE:

(2000 – 2001): 2 N·m (0.2 kgf·m, 1.4 lbf·ft)

(After 2001): 4 N·m (0.4 kgf·m, 3.0 lbf·ft)

2000 – 2001: Install and tighten the drain plug to the specified torque.

TORQUE: 7 N·m (0.7 kgf·m, 5.1 lbf·ft)

After 2001: Install the hose guide as shown.

Connect the air vent hoses and overflow hose.

2000 – 2001 Shown:
DRAIN PLUG



After 2001 Shown:



2000 – 2001 Shown:

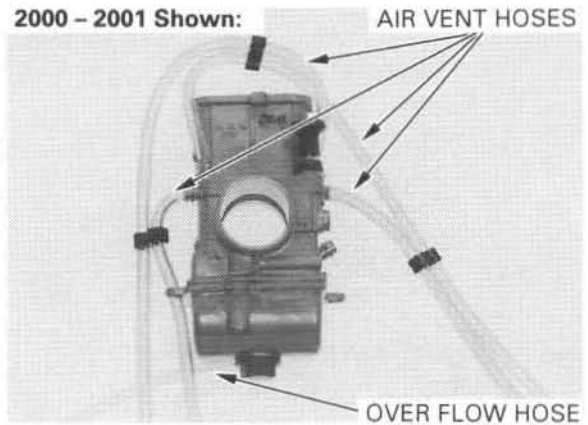

After 2001 Shown:

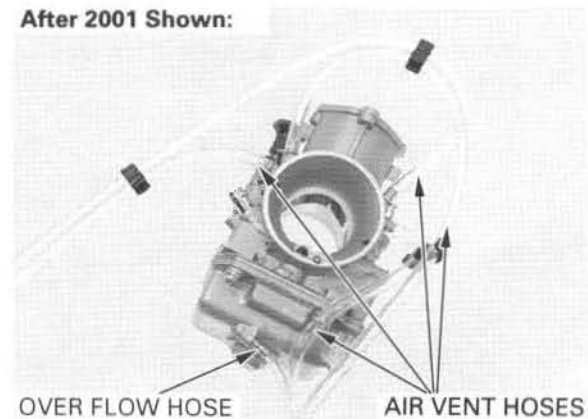

Install the jet needle clip to the jet needle.

STANDARD CLIP POSITION: 3rd groove

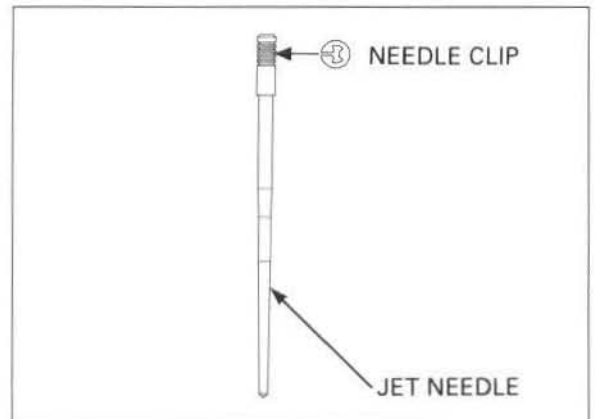

Install the jet needle into the throttle valve.
Install the cable holder into the throttle valve then tighten the cable holder to the specified torque.

TORQUE: 3 N•m (0.3 kgf•m, 2.2 lbf•ft)

2000 – 2001 Shown:
THROTTLE VALVE

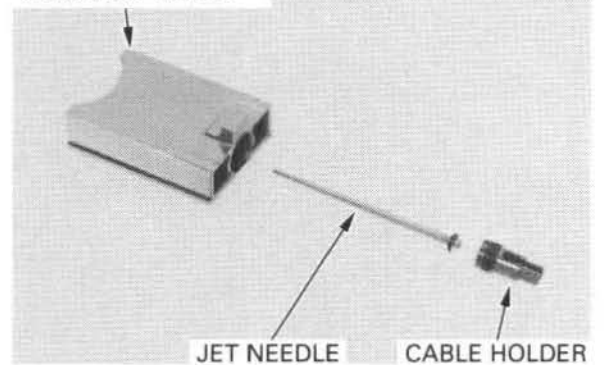

After 2001 Shown:

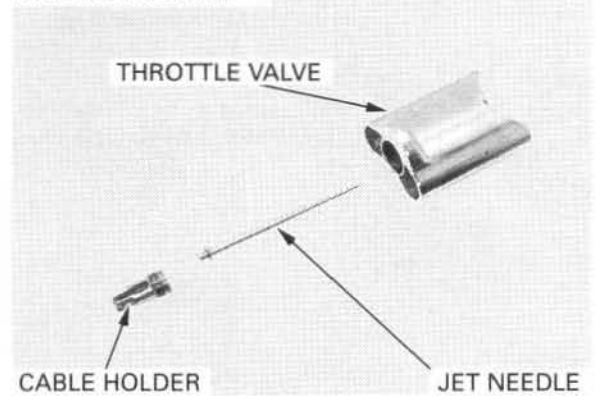

Align the throttle valve spring and collar to the throttle cable.

Compress the throttle valve spring and insert the throttle cable into the cable holder.

Install the collar by aligning the tab of the collar with the cut-out in the cable holder.

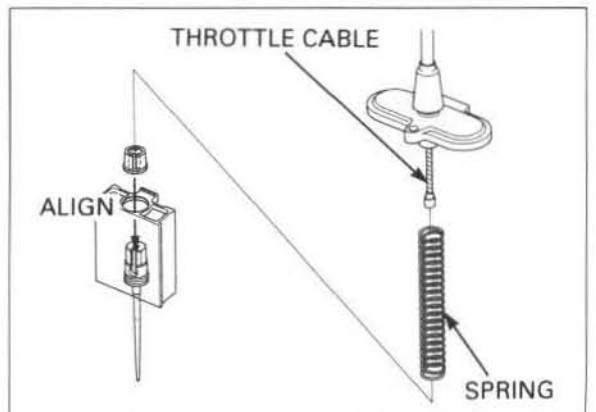

INSTALLATION

2000 – 2001: Loosely install the carburetor.
Move the carburetor to the left and slide the throttle valve assembly into the carburetor with the cut-out and tab side facing to the air cleaner.

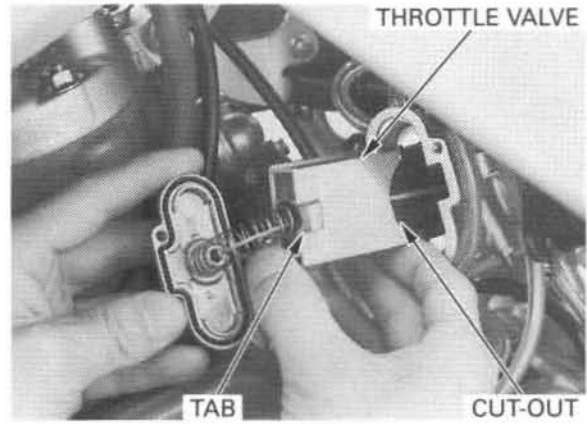

After 2001: Slide the throttle valve assembly into the carburetor.

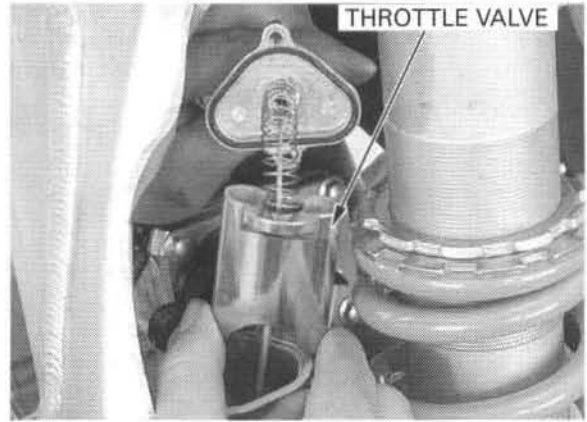

Install the carburetor top cover and tighten the screws to the specified torque.

TORQUE:

2000: 4 N•m (0.4 kgf•m, 2.9 lbf•ft)
After 2000: 2 N•m (0.2 kgf•m, 1.4 lbf•ft)

**2000 – 2001 Shown:
CARBURETOR TOP**

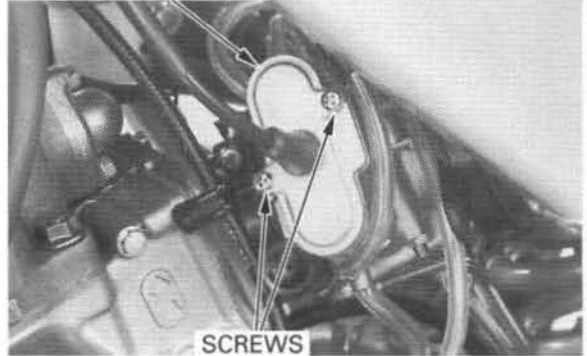

**After 2001 Shown:
CARBURETOR TOP**

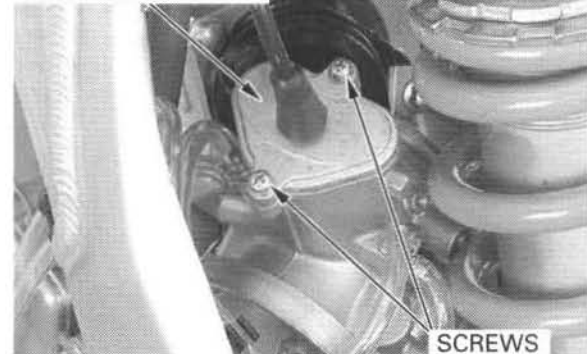

Align the lug on the carburetor with the groove of the carburetor insulator.

After 2001: Install the sub-frame (page 2-4).

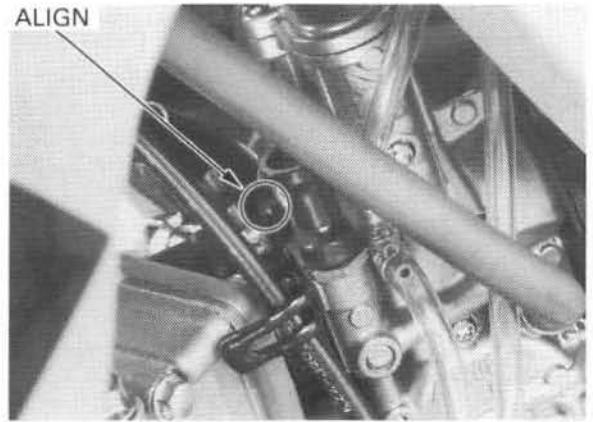

Tighten the insulator and connecting hose band screws securely.

After installation adjust the following:

- Throttle grip free play (page 3-5)
- Air screw adjustment (page 4-4)

After installation check the following:

- Secondary air leaks around the insulator and connecting tube
- Fuel leaks around the fuel hose and carburetor
- Route the overflow hose, air vent hose and fuel hose

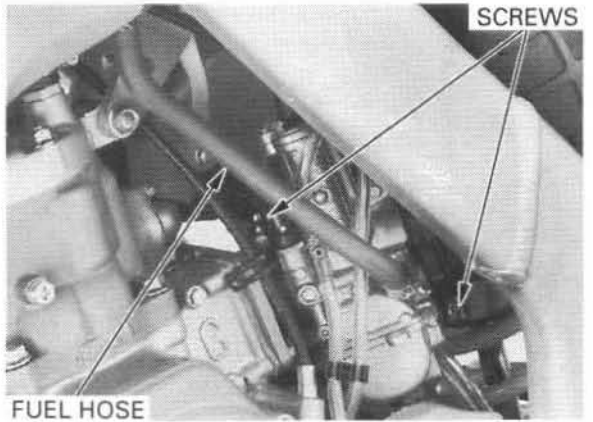

REED VALVE

REMOVAL

Remove the carburetor (page 4-9).

Remove the bolts, clutch cable clamp and insulator.

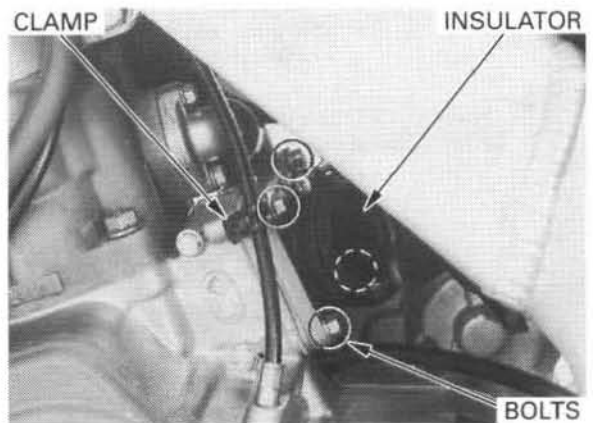

2000 - 2001: Remove the reed valve and gasket.

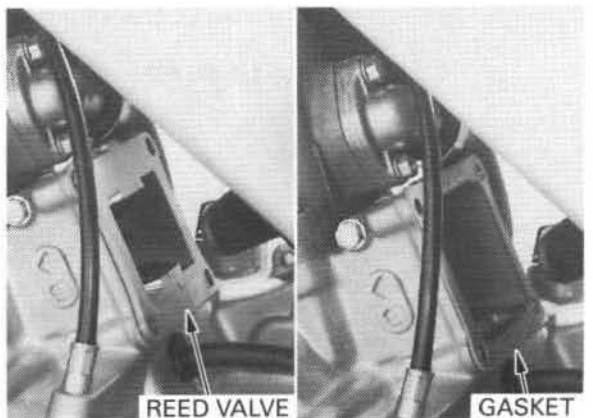

FUEL SYSTEM

After 2001: Remove the reed valve, gasket, spacer and gasket.

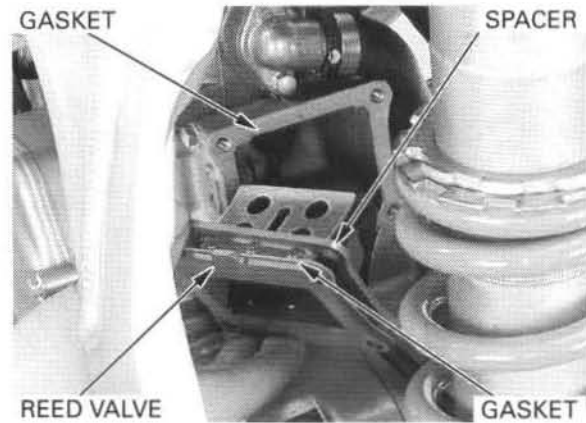

Check the reed valve for fatigue or damage and replace the reed valve if necessary.

Check the reed valve stopper for cracks, damage and clearance from the reed and replace the reed valve stopper if necessary.

DISASSEMBLY/ASSEMBLY

Remove the screws, reed valve stopper and reed valve.

Replace the reed valve after 3 races or about 7.5 hours.

Install the reed valve and reed valve stopper by aligning the cut-out in the reed valve and the cut-out of the reed valve stopper.

Clean the screw threads.

Apply a small amount of locking agent to the tip of the screw threads.

Tighten the screws to the specified torque.

TORQUE: 1 N•m (0.1 kgf•m, 0.7 lbf•ft)

NOTE:

Do not apply a locking agent to the reed valve.

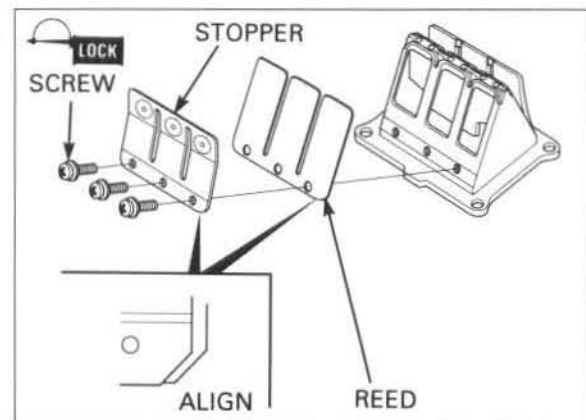
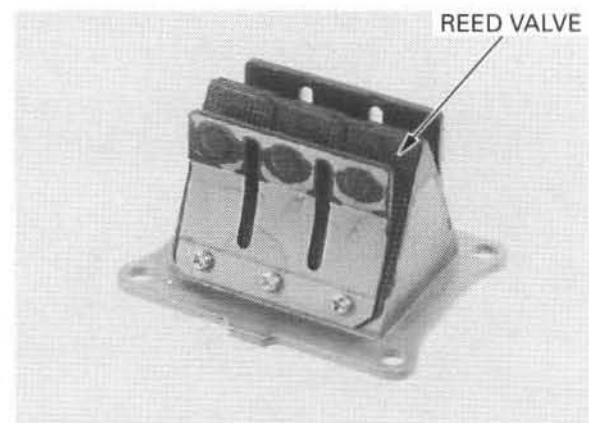

After installation, check for reed valve clearance.

SERVICE LIMIT: 0.2 mm (0.01 in)

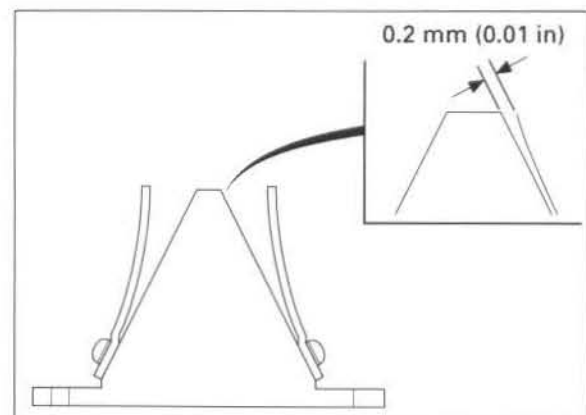

INSTALLATION

2000 – 2001: Install the new gasket to the crankcase.
Install the reed valve with its tab facing up.

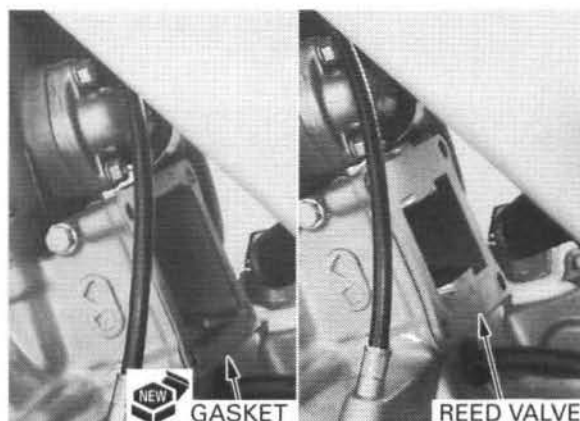

After 2001: Install the new gasket to the crankcase.
Install the spacer and new gasket to the crankcase.
Install the reed valve with its tab facing up.

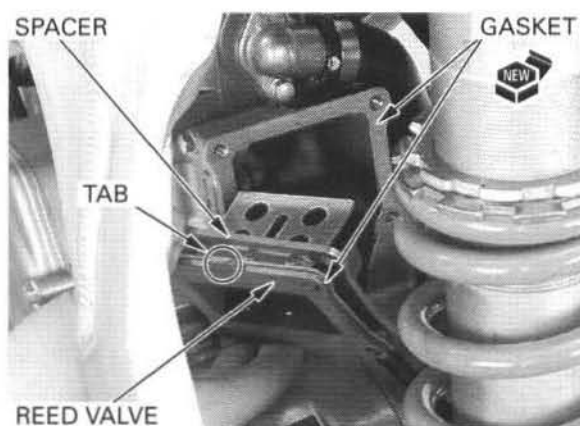

Install the insulator, clutch cable holder and bolts.
Tighten the bolts securely.

Install the carburetor (page 4-20).

After installation check the following:
– Secondary air leaks around the insulator and connecting hose
– Fuel leaks around the fuel hose and carburetor

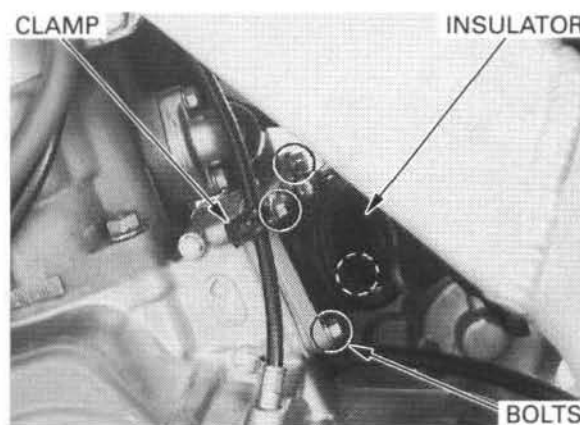

AIR CLEANER HOUSING

REMOVAL

Remove the sub-frame (page 2-4).

Remove the screws and mud guard.

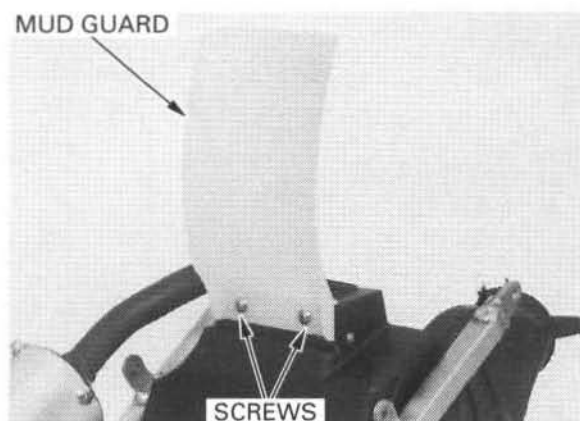

FUEL SYSTEM

Remove the bolts and air cleaner housing from the sub-frame.

Remove the air cleaner element (page 3-5). Check the carburetor connecting tube to see if it is sealing properly at the air cleaner housing. Check the air cleaner housing for damage.

Remove the carburetor connecting tube from the air cleaner housing and seal thoroughly if any sign of inadequate sealing is detected.

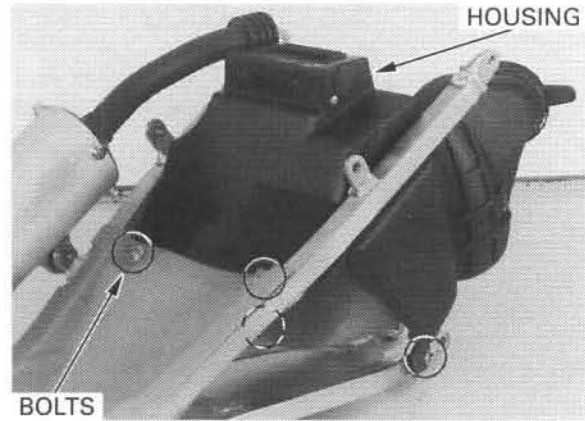

INSTALLATION

Air cleaner housing installation is in the reverse order of removal.

2000 - 2001:

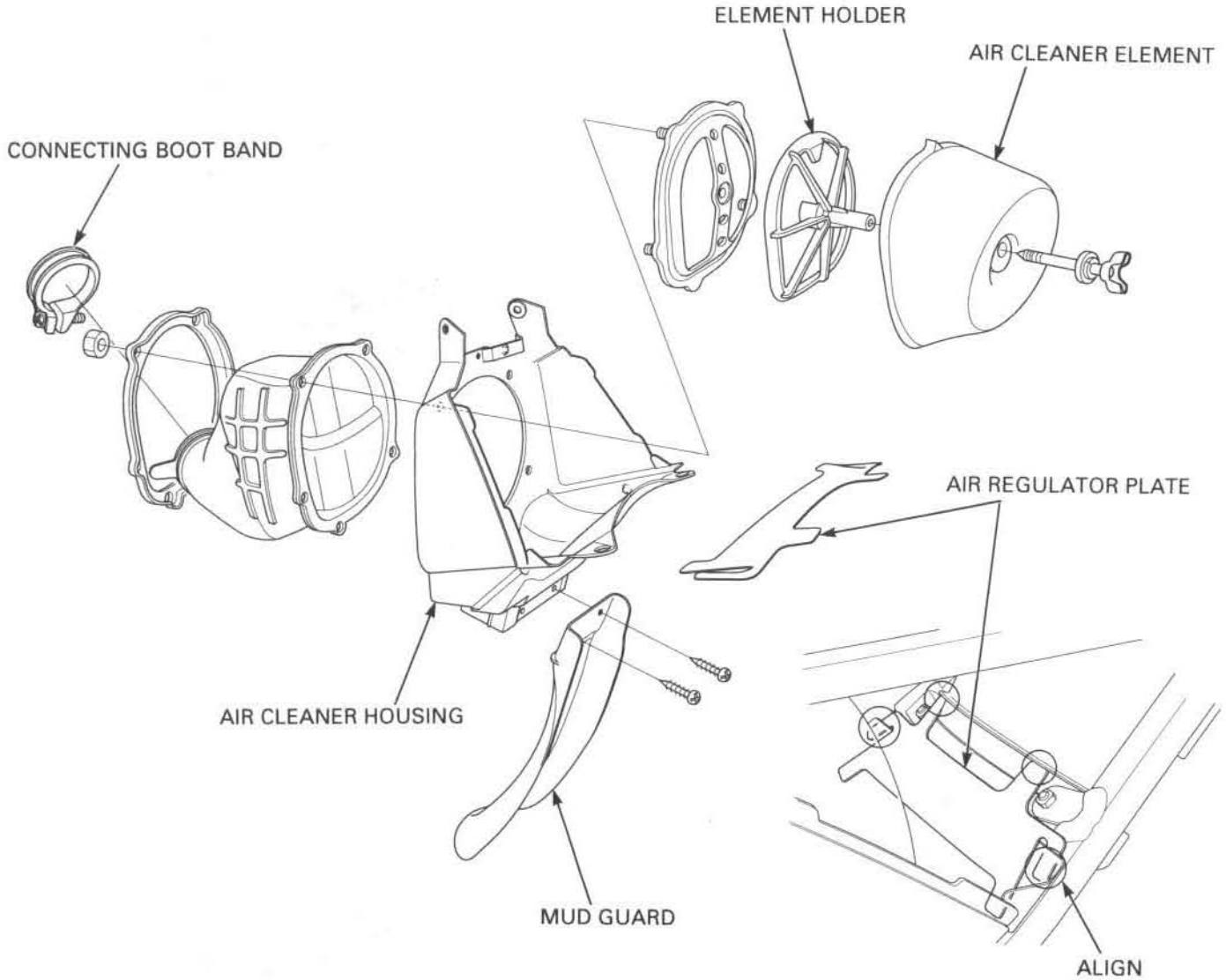

After 2001:

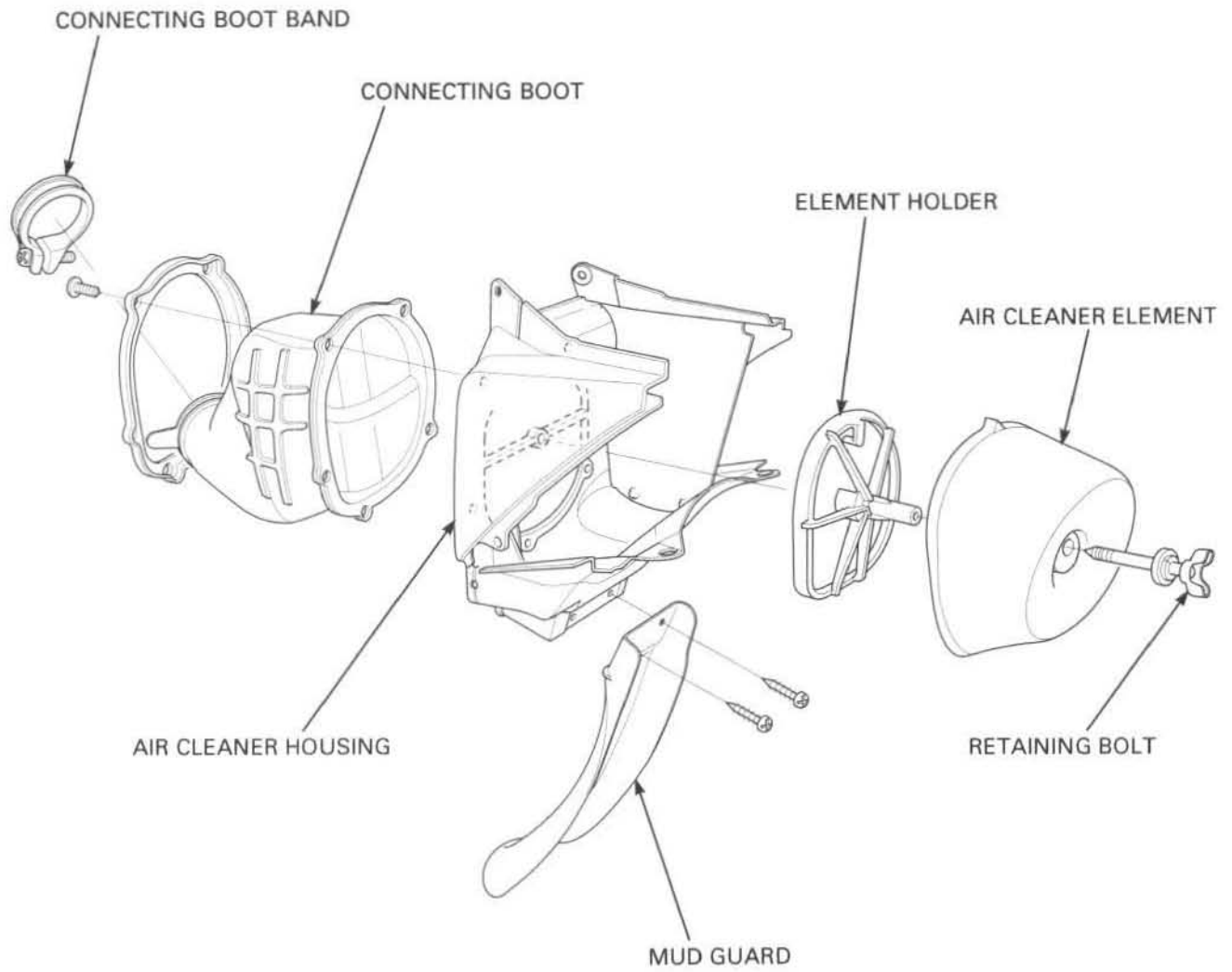

COOLING SYSTEM

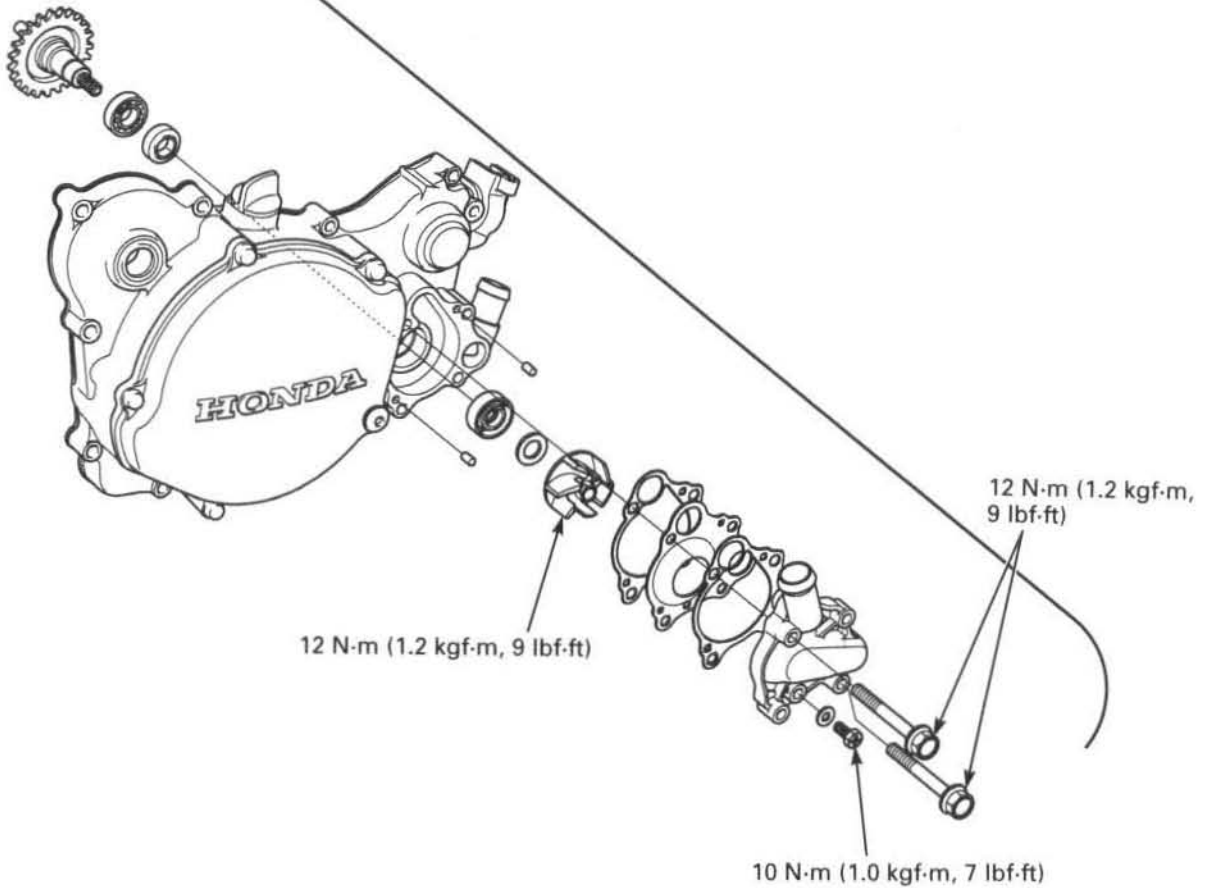
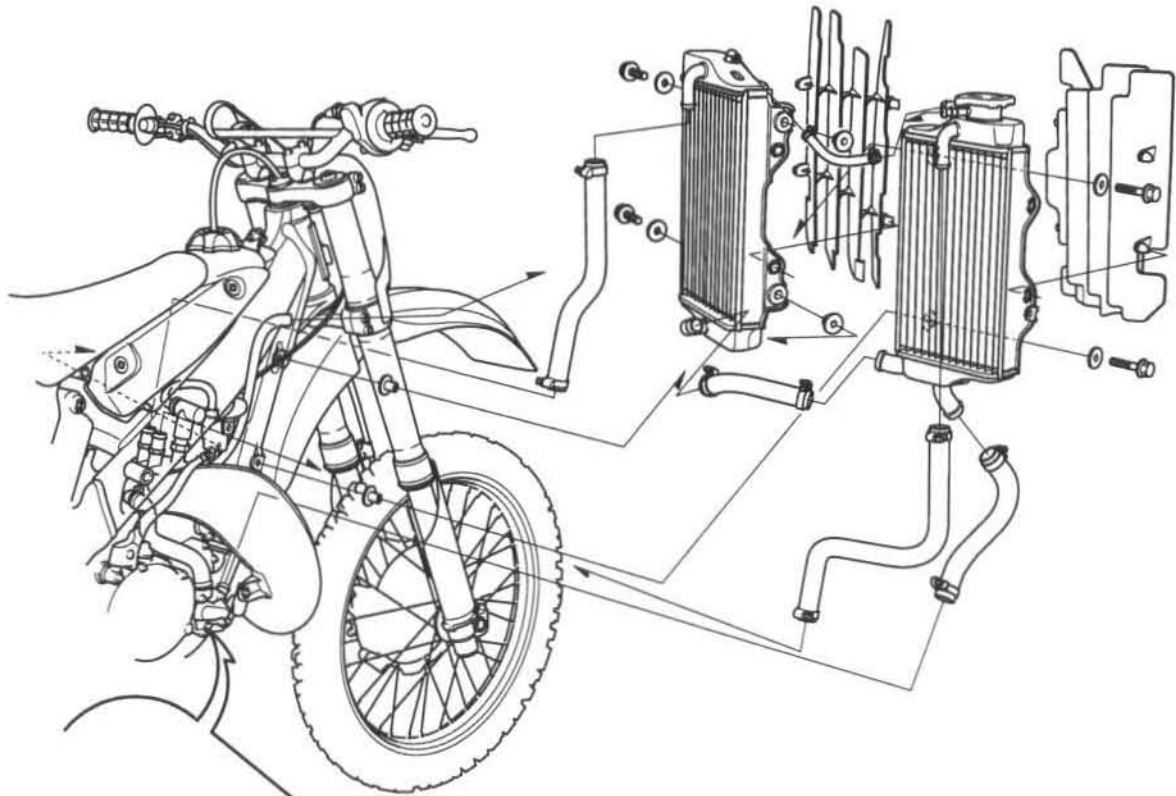

5. COOLING SYSTEM

SERVICE INFORMATION	5-1	COOLANT REPLACEMENT	5-4
TROUBLESHOOTING	5-2	RADIATOR	5-5
SYSTEM TESTING	5-3	WATER PUMP	5-7

SERVICE INFORMATION

GENERAL

⚠ WARNING

- Wait until the engine is cool before slowly removing the radiator cap. Removing the cap while the engine is hot and the coolant is under pressure may cause serious scalding.
- Radiator coolant is toxic. Keep it away from eyes, mouth, skin and clothes.
 - If any coolant gets in your eyes, rinse them with water and consult a doctor immediately.
 - If any coolant is swallowed, induce vomiting, gargle and consult a physician immediately.
 - If any coolant gets on your skin or clothes, rinse thoroughly with plenty of water.
- KEEP OUT OF REACH OF CHILDREN.

CAUTION:

Using coolant with silicate inhibitors may cause premature wear of water pump seals or blockage of radiator passages. Using tap water may cause engine damage.

- Use only distilled water and ethylene glycol in the cooling system. A 50 – 50 mixture is recommended for maximum corrosion protection. Do not use alcohol-based antifreeze.
- All cooling system services can be done with the engine in the frame.
- Avoid spilling coolant on painted surfaces.
- After servicing the system, check for leaks with a cooling system tester.
- Recycle used coolant in an ecologically correct manner.

SPECIFICATIONS

ITEM		SPECIFICATIONS
Coolant capacity	at change	0.88 liter (0.930 US qt, 0.774 Imp qt)
	at disassembly	0.97 liter (1.025 US qt, 0.854 Imp qt)
Radiator cap relief pressure		108 – 137 kPa (1.1 – 1.4 kgf/cm ² , 16 – 20 psi)
Recommended antifreeze		Pro Honda HP Coolant or an equivalent high quality ethylene glycol antifreeze containing silica-free corrosion inhibitors

TORQUE VALUES

Water pump impeller	12 N•m (1.2 kgf•m, 9 lbf•ft)
Coolant drain bolt	10 N•m (1.0 kgf•m, 7 lbf•ft)
Water pump cover bolt	12 N•m (1.2 kgf•m, 9 lbf•ft)

COOLING SYSTEM

TOOLS

Attachment, 24 x 26 mm	07746 - 0010700
Pilot, 12 mm	07746 - 0040200
Driver	07749 - 0010000
Bearing remover, 7 mm	07931 - KA30000 - Not available in U.S.A.
Bearing driver, 7 mm	07931 - KA30100 - Not available in U.S.A.
Bearing remover set, 12 mm	07936 - 1660001 - Not available in U.S.A.
- Remover weight	07741 - 0010201 or 07936 - 371020A or 07936 - 3710200
- Remover, 12 mm	07936 - 1660101 or 07936 - 166010A (U.S.A. only)
- Remover head, 12 mm	07936 - 1660110 - Not available in U.S.A.
- Remover shaft	07936 - 1660120 - Not available in U.S.A.
Water seal driver	07945 - KA30000 or 07965 - 415000A (U.S.A. only) or GN-AH-065-415

TROUBLESHOOTING

Engine temperature too high

- Faulty radiator cap
- Insufficient coolant
- Passages blocked in radiator, hoses or water jacket
- Radiator air passages clogged with dirt
- Air in system
- Faulty water pump

Coolant leak

- Faulty water pump oil and water seal
- Deteriorated water pump oil and water seal
- Damaged or deteriorated gasket
- Loose hose connection or clamp
- Damaged or deteriorated hose
- Faulty radiator cap
- Damaged radiator

SYSTEM TESTING

⚠ WARNING

The engine must be cool before removing the radiator cap, or severe scalding may result.

COOLANT (HYDROMETER TEST)

Remove the radiator cap.

Test the coolant gravity using a hydrometer.

STANDARD COOLANT CONCENTRATION: 50 %

Look for contamination and replace the coolant if necessary.

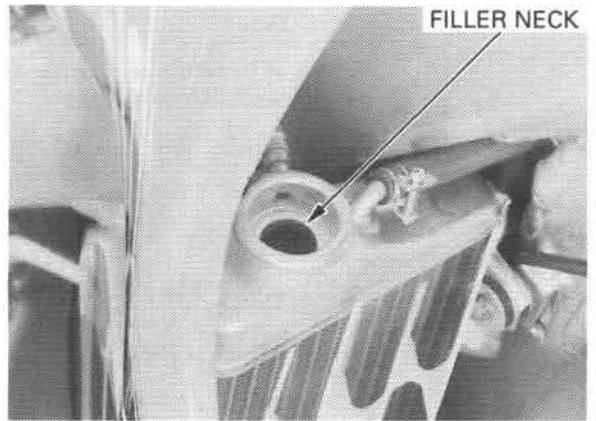
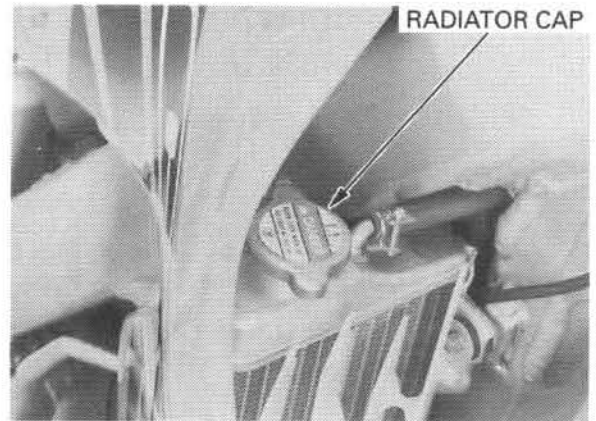

SPECIFIC GRAVITY CHART

Coolant temperature °C (°F)	Coolant ratio %											
	0 (32)	5 (41)	10 (50)	15 (59)	20 (68)	25 (77)	30 (86)	35 (95)	40 (104)	45 (113)	50 (122)	
5	1.009	1.009	1.008	1.008	1.007	1.006	1.005	1.003	1.001	0.999	0.997	
10	1.018	1.017	1.017	1.016	1.015	1.014	1.013	1.011	1.009	1.007	1.005	
15	1.028	1.027	1.026	1.025	1.024	1.022	1.020	1.018	1.016	1.014	1.012	
20	1.036	1.035	1.034	1.033	1.031	1.029	1.027	1.025	1.023	1.021	1.019	
25	1.045	1.044	1.043	1.042	1.040	1.038	1.036	1.034	1.031	1.028	1.025	
30	1.053	1.052	1.051	1.049	1.047	1.045	1.043	1.041	1.038	1.035	1.032	
35	1.063	1.062	1.060	1.058	1.056	1.054	1.052	1.049	1.046	1.043	1.040	
40	1.072	1.070	1.068	1.066	1.064	1.062	1.059	1.056	1.053	1.050	1.047	
45	1.080	1.078	1.076	1.074	1.072	1.069	1.066	1.063	1.060	1.057	1.054	
50	1.086	1.084	1.082	1.080	1.077	1.074	1.071	1.068	1.065	1.062	1.059	
55	1.095	1.093	1.091	1.088	1.085	1.082	1.079	1.076	1.073	1.070	1.067	
60	1.100	1.098	1.095	1.092	1.089	1.086	1.083	1.080	1.077	1.074	1.071	

COOLING SYSTEM

RADIATOR CAP/SYSTEM PRESSURE INSPECTION

Wet the sealing surface with water.

Remove the radiator cap (page 5-3).
Install the radiator cap on the tester.

Pressure test the radiator cap.
Replace the radiator cap if it does not hold pressure, or if relief pressure is too high or too low.
It must hold specified pressure for at least 6 seconds.

RADIATOR CAP RELIEF PRESSURE:

108 – 137 kPa (1.1 – 1.4 kgf/cm², 16 – 20 psi)

Pressure the radiator, engine and hoses, and check for leaks.

CAUTION:

Excessive pressure can damage the cooling system components. Do not exceed 137 kPa (1.4 kgf/cm², 20 psi).

Repair or replace components if the system will not hold specified pressure for at least 6 seconds.



COOLING SYSTEM TESTER
COMMERCIALY AVAILABLE



COOLING SYSTEM TESTER
COMMERCIALY AVAILABLE

COOLANT REPLACEMENT

PREPARATION

⚠ WARNING

- Radiator coolant is toxic. Keep it away from eyes, mouth, skin and clothes.
 - If any coolant gets in your eyes, rinse them with water and consult a doctor immediately.
 - If any coolant in swallowed, induce vomiting, gargle and consult a physician immediately.
 - If any coolant gets on your skin or clothes, rinse thoroughly with plenty of water.
- KEEP OUT OF REACH OF CHILDREN.

CAUTION:

Using coolant with silicate corrosion inhibitors may cause premature wear of water pump seals or blockage of radiator passages. Using tap water may cause engine damage.

NOTE:

- The effectiveness of coolant decreases with the accumulation of rust or if there is a change in the mixing proportion during usage. Therefore, for best performance change the coolant regularly as specified in the maintenance schedule.
- Mix only distilled, low mineral water with the anti-freeze.

RECOMMENDED ANTIFREEZE:

Pro Honda HP Coolant or an equivalent high quality ethylene glycol antifreeze containing silica-free corrosion inhibitors

RECOMMENDED MIXTURE:

50 – 50 (Distilled water and recommended anti-freeze)

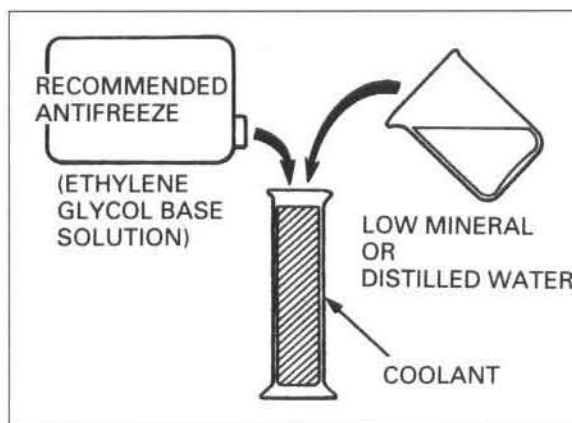

REPLACEMENT/AIR BLEEDING

⚠ WARNING

The engine must be cool before servicing the cooling system, or severe scalding may result.

NOTE:

When filling the system, place the motorcycle in a vertical position on a flat, level surface.

Remove the radiator cap.

Remove the drain bolt on the water pump cover and cylinder then drain the system coolant.

Reinstall the drain bolt with the new sealing washers. Tighten the drain bolt to the specified torque.

TORQUE: 10 N·m (1.0 kgf·m, 7 lbf·ft)

Fill the system with the recommended coolant through the filler opening up to filler neck.

CAPACITY: 0.90 liter (0.95 US oz, 0.79 Imp oz)

Lean the machine approximately 20° right and left several times to bleed air trapped in the cooling system. If the coolant level drops, add more coolant and repeat air bleeding procedure.

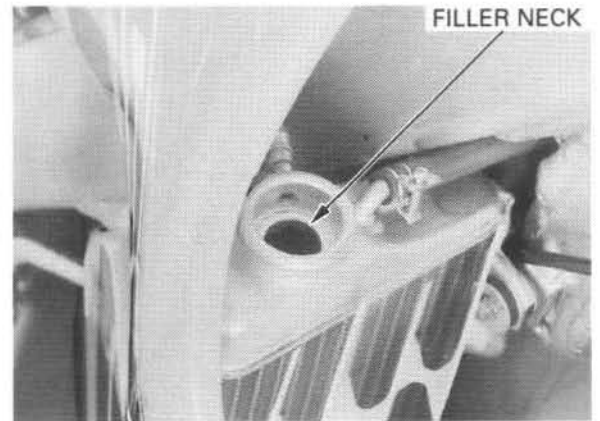
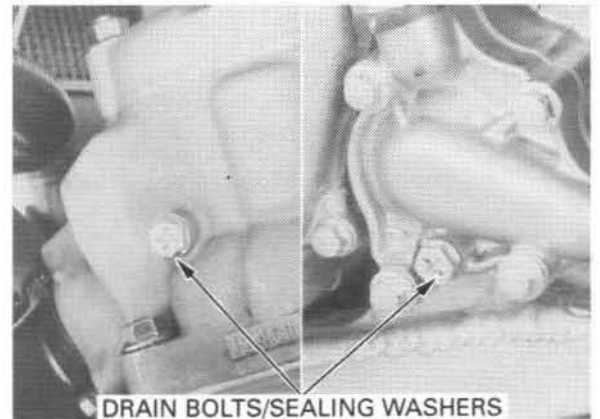
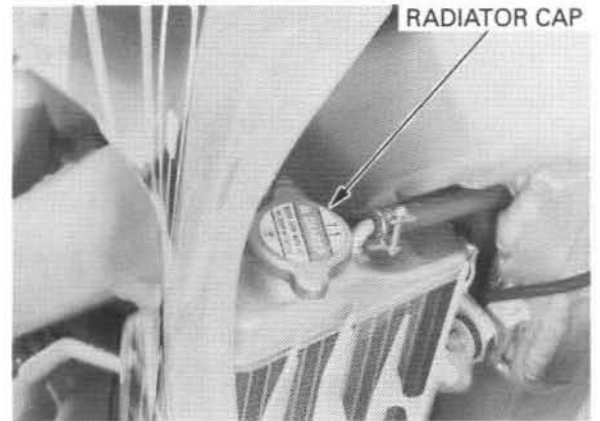

RADIATOR

REMOVAL

Drain the coolant (page 5-5).
Remove the radiator shrouds (page 2-3).

Remove the right and left radiator grills.

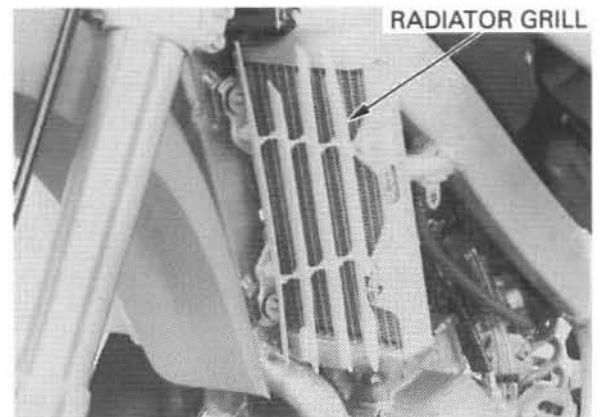

COOLING SYSTEM

Note the direction of the hose clamps.

Loosen the upper radiator hose clamps and disconnect the upper radiator hoses.

Loosen the lower radiator hose clamp and disconnect the lower radiator hose.

Loosen the upper and lower joint hose clamps and disconnect the upper and lower joint hose.

Remove the overflow hose from the right side radiator.

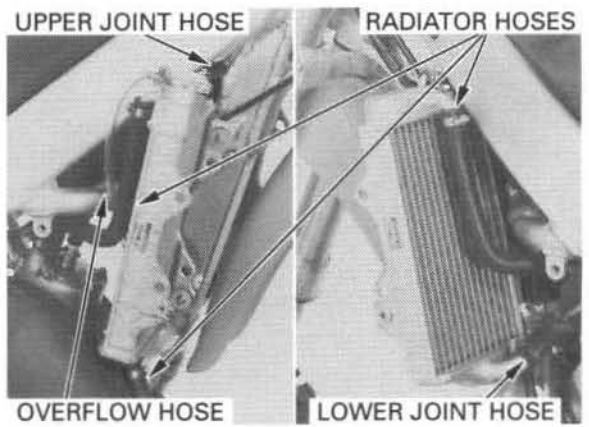

Remove the upper and lower mounting bolts and collars.

Remove the radiator.

CAUTION:

Be careful not to damage the radiator core.

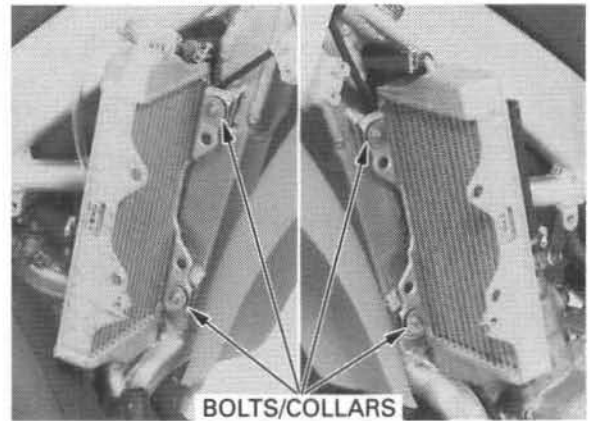

INSTALLATION

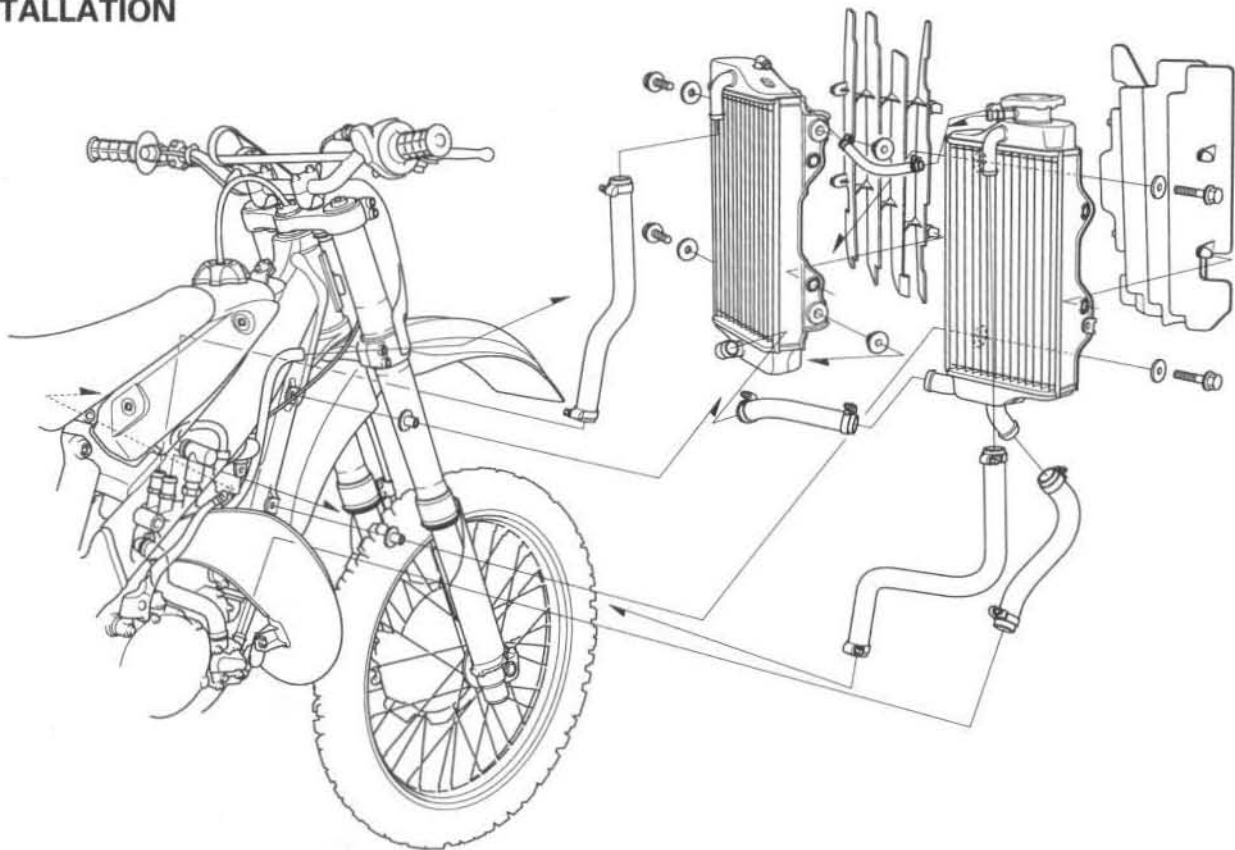

CAUTION:

Be careful not to damage the radiator core.

Installation is essentially the reverse order of removal.

Add the recommend coolant mixture up to the filler neck and bleed the air (page 5-4).

After installation, check the radiator and radiator hoses for leaks.

Install the radiator shrouds (page 2-3).

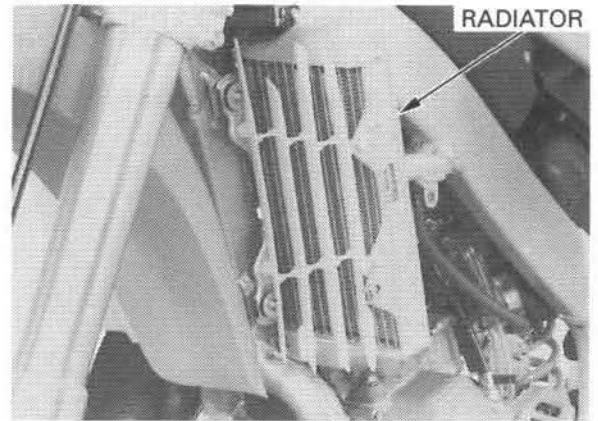

WATER PUMP

MECHANICAL SEAL INSPECTION

Inspect the telltale hole for signs of coolant leakage. If there is leakage, the mechanical seal is defective and replace the water pump as an assembly.

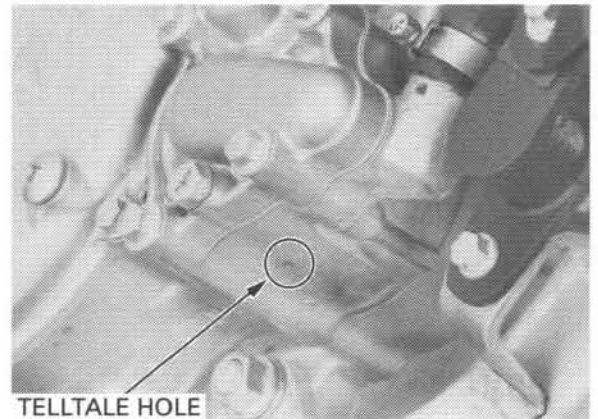

REMOVAL

Drain the coolant (page 5-5).

Remove the four flange bolts and water pump cover.

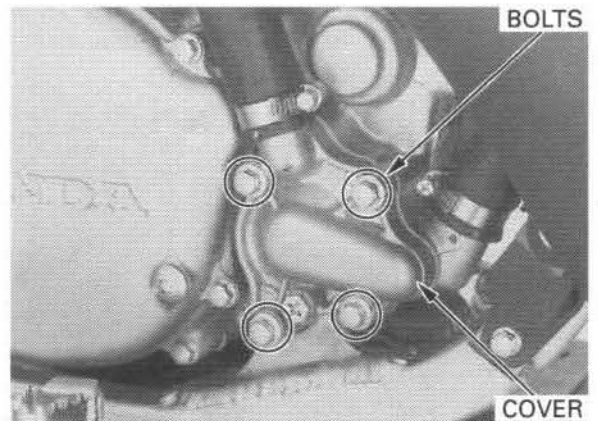

Remove the outer gasket and plate.

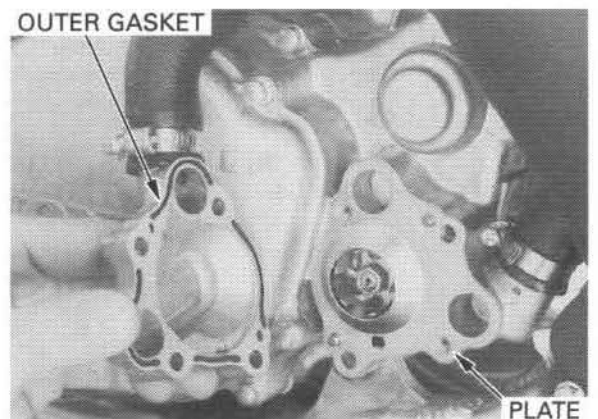

COOLING SYSTEM

Remove the inner gasket and dowel pins.
Remove the impeller and plain washer.

Remove the right crankcase cover (page 9-3).

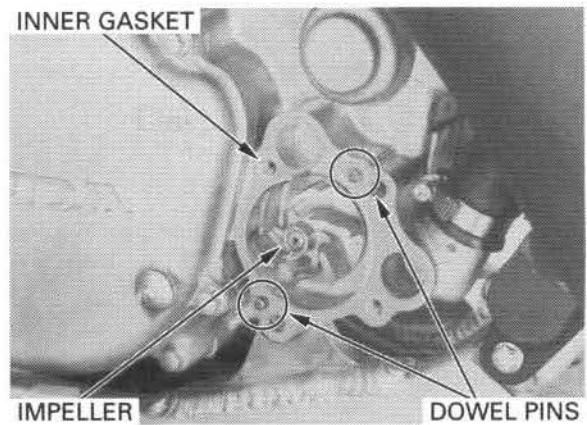

Remove the water pump shaft from the right crankcase cover.

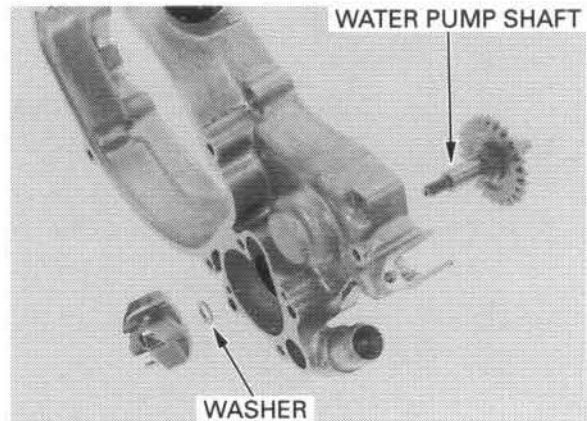

Check the water pump shaft and gear to be sure they are not bent or damaged.

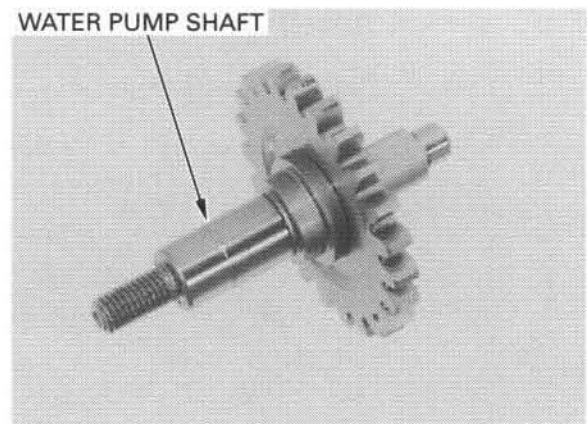

Turn the inner race of the water pump shaft bearing with your finger. The bearing should turn smoothly and quietly. Also check that the bearing outer race fits tightly in the right crankcase cover.

Replace the water pump shaft bearing if necessary (page 5-10).

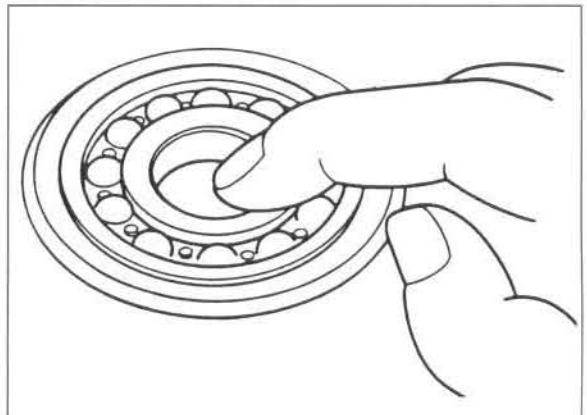

Check the water seal for damage or deterioration.

Replace the water seal if necessary (page 5-10).

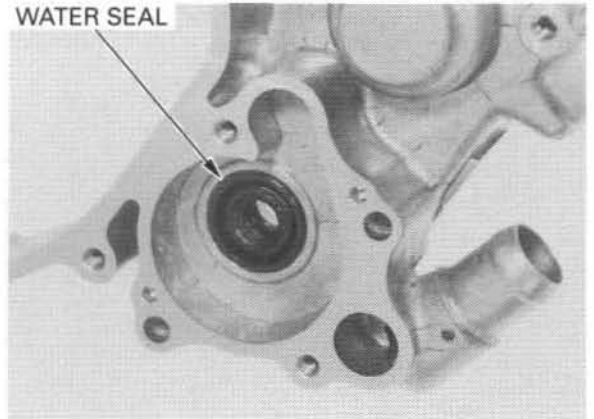

BEARING REPLACEMENT

RIGHT CRANKCASE COVER SIDE:

Remove the water pump shaft bearing using the special tools.

TOOLS :

- | | |
|-----------------------------------|---|
| Bearing remover set, 12 mm | 07936 - 1660001 Not available in U.S.A. |
| - Remover weight | 07741 - 0010201 or 07936 - 371020A or 07936 - 3710200 |
| - Remover 12 mm | 07936 - 1660101 or 07936 - 166010A (U.S.A. only) |
| - Remover head, 12 mm | 07936 - 1660100 Not available in U.S.A. |
| - Remover shaft | 07936 - 1660120 Not available in U.S.A. |

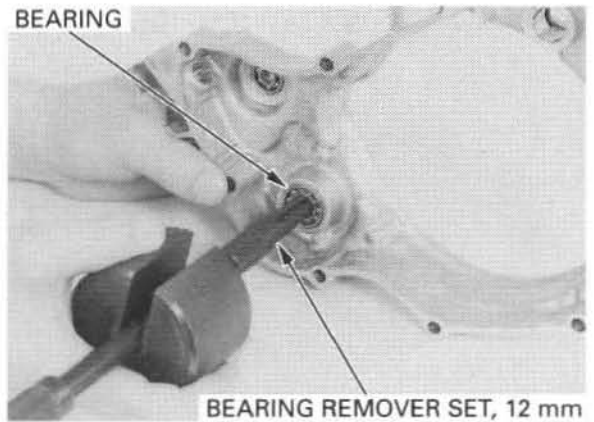

Drive in the new bearing into the right crankcase cover using the special tools as shown.

TOOLS :

- | | |
|-------------------------------|-----------------|
| Driver | 07749 - 0010000 |
| Attachment, 24 x 26 mm | 07746 - 0010700 |
| Pilot, 12 mm | 07746 - 0040200 |

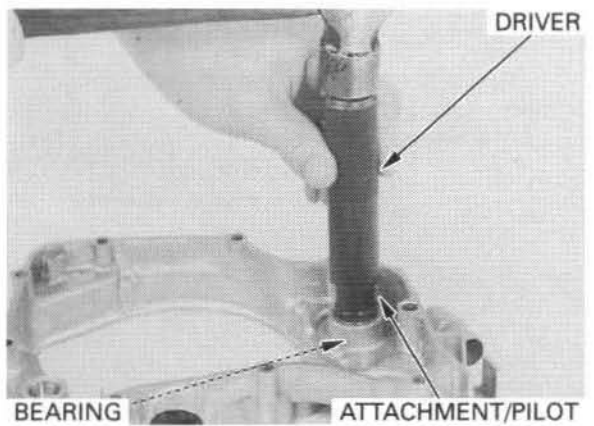

RIGHT CRANKCASE SIDE:

Remove the water pump shaft bearing using the special tool.

TOOL :

- | | |
|------------------------------|---|
| Bearing remover, 7 mm | 07931 - KA30000 not available in U.S.A. |
|------------------------------|---|

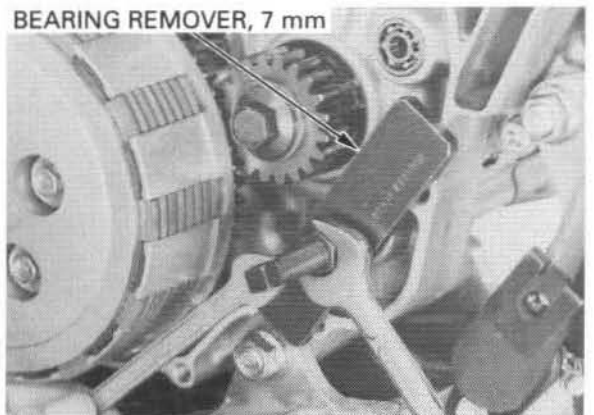

COOLING SYSTEM

Drive in the new bearing into the right crankcase using the special tool as shown.

TOOL :

Bearing driver, 7 mm

07931 - KA30100
not available in
U.S.A.

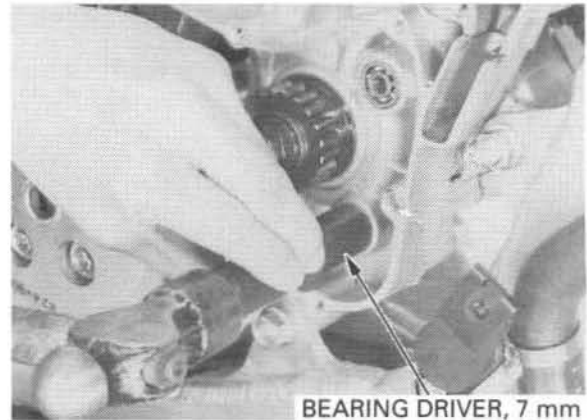

WATER/OIL SEAL REPLACEMENT

Remove the water pump shaft bearing (page 5-9).
Drive out the water seal and oil seal from the right crankcase cover.

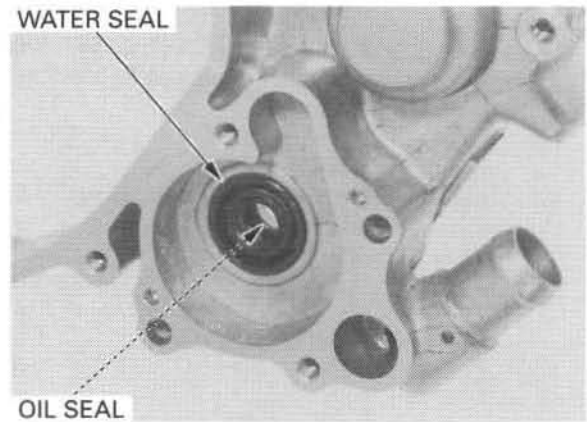

Install the water seal driver into the right crankcase cover as shown.

Drive in the new water seal.

Be careful not to damage the water seal lips during installation.

TOOLS :

Water seal driver

Mechanical seal installer

07945 - KA30000 or
07965 - 415000A
(U.S.A. only) or
GN-AH-065-415

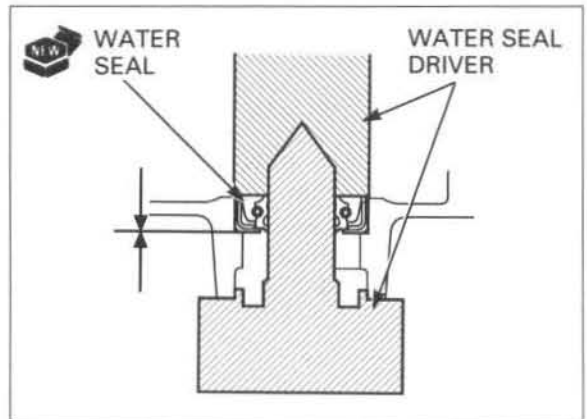

Install the new oil seal into the right crankcase cover as shown.

Install the water pump shaft bearing (page 5-9).

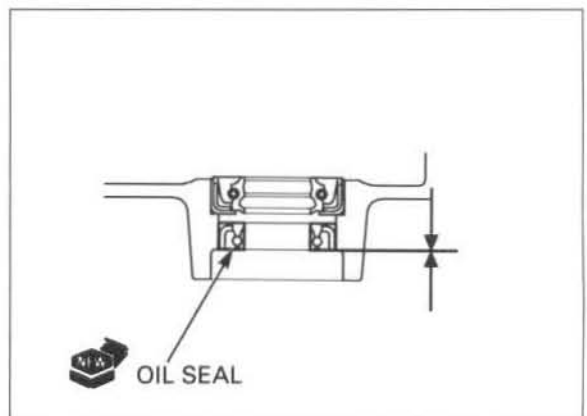

INSTALLATION

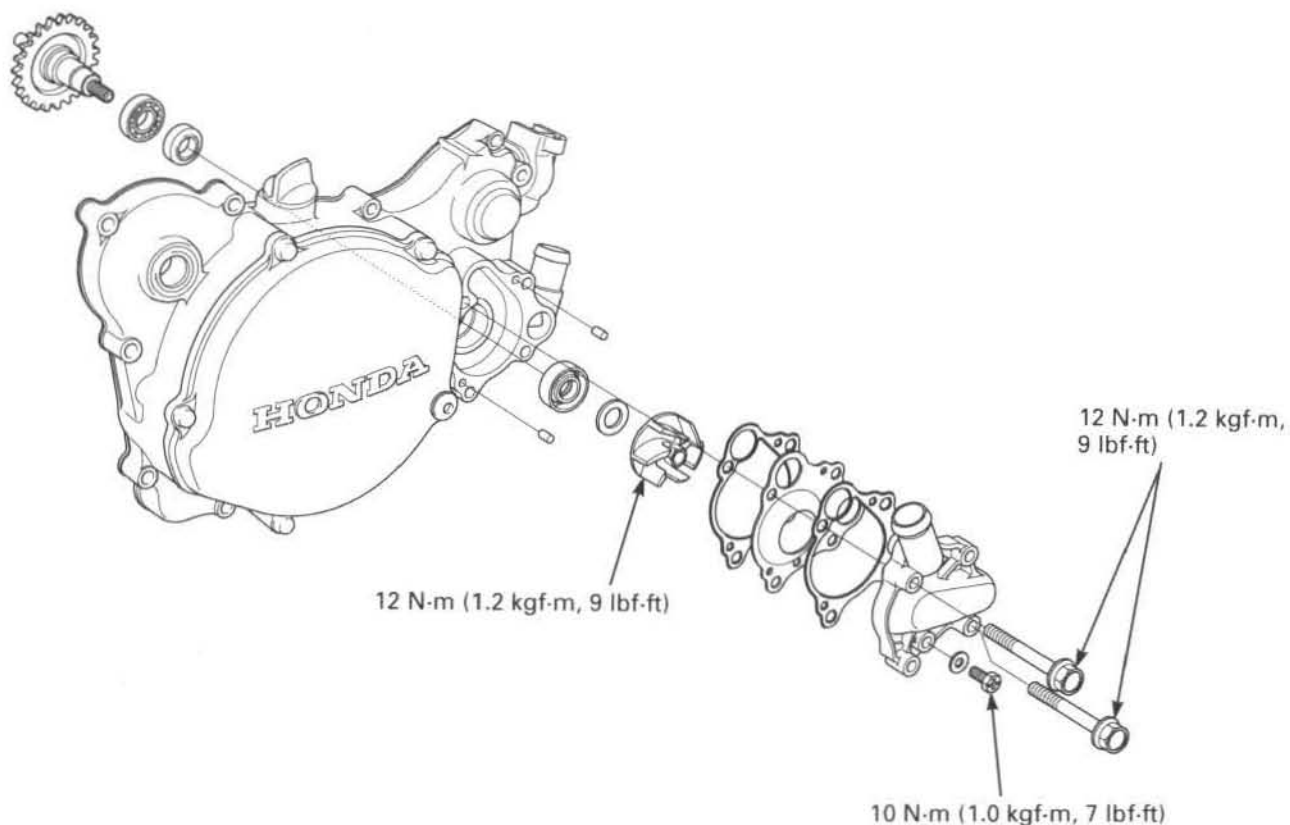

Install the water pump shaft to the right crankcase cover.

Install the right crankcase cover (page 9-3).

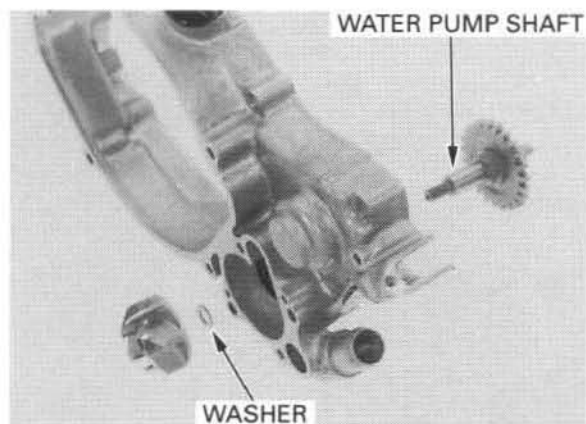

Install the plain washer and impeller onto the water pump shaft.
Tighten the impeller to the specified torque.

TORQUE: 12 N·m (1.2 kgf·m, 9 lbf·ft)

Install the dowel pins and new inner gasket.

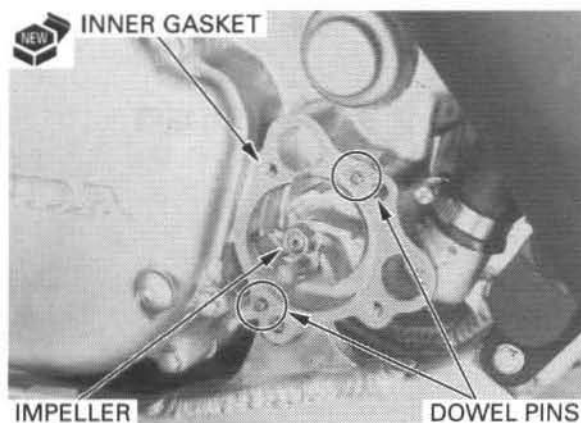

COOLING SYSTEM

Install the plate and new outer gasket.

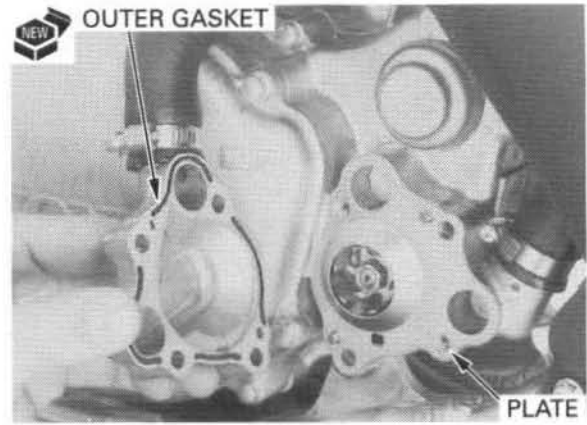

Install the water pump cover and tighten the four flange bolts to the specified torque.

TORQUE: 12 N·m (1.2 kgf·m, 9 lbf·ft)

Add the recommend coolant mixture up to the filler neck and bleed the air (page 5-5).

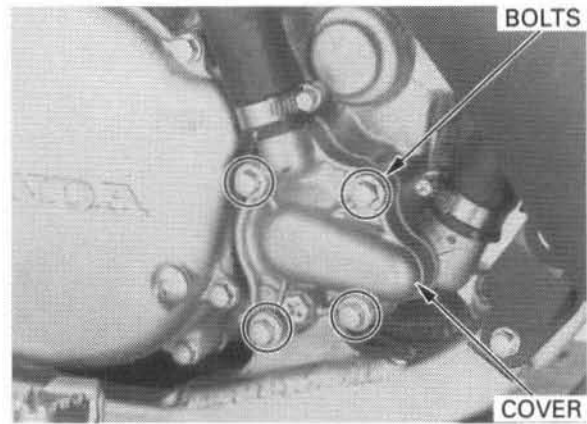

MEMO

ENGINE REMOVAL/INSTALLATION

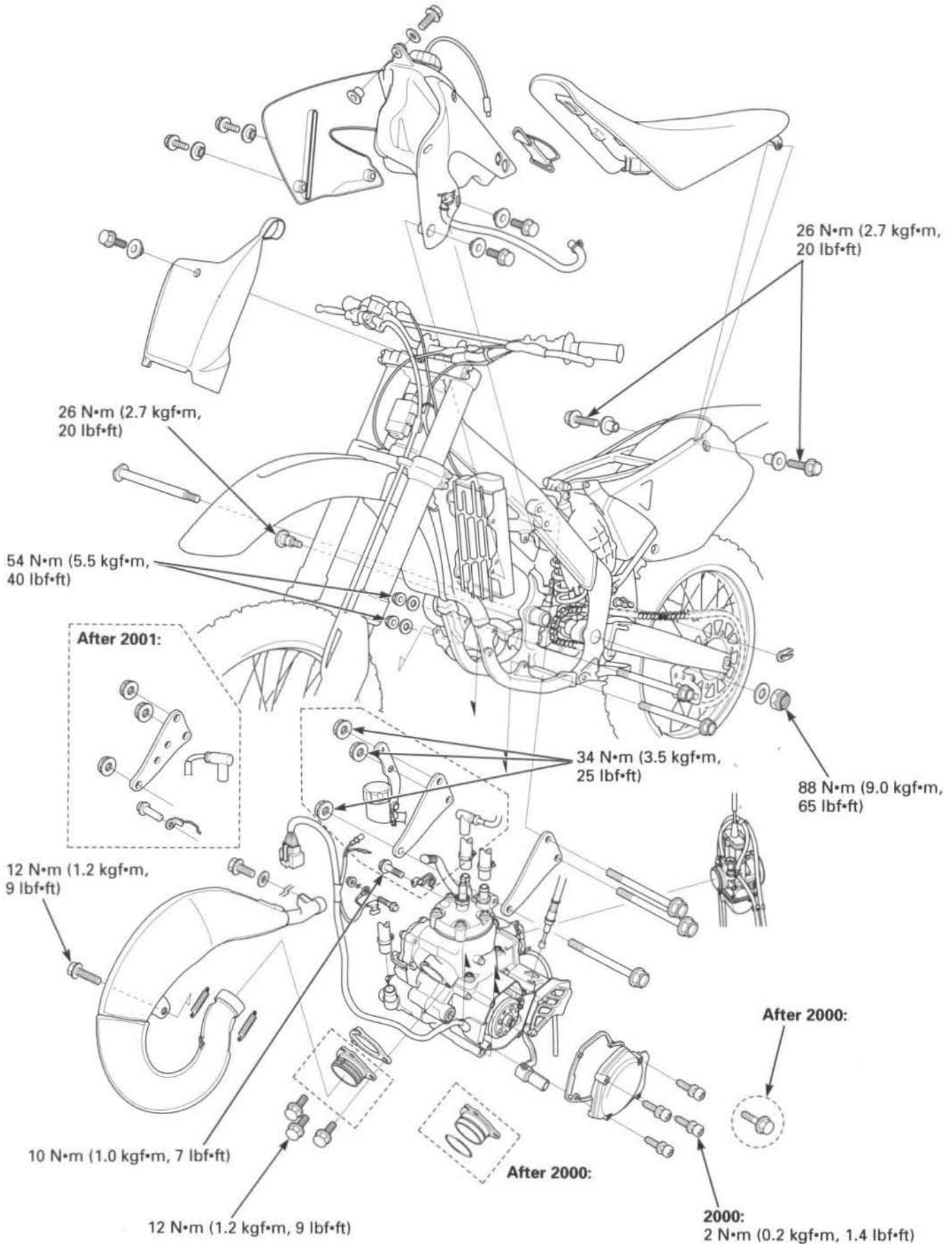

6. ENGINE REMOVAL/INSTALLATION

SERVICE INFORMATION

6-1

ENGINE INSTALLATION

6-4

ENGINE REMOVAL

6-2

SERVICE INFORMATION

GENERAL

- During engine removal and installation, support the motorcycle using a workstand.
- The following components can be serviced with the engine installed in the frame.
 - Alternator (Section 14)
 - Clutch/kickstarter/gearshift linkage (Section 9)
 - Cylinder head/cylinder/piston (Section 7)
 - RC valve system (Section 8)
- The following components require engine removal for service.
 - Crankshaft/transmission (Section 10)

6

SPECIFICATIONS

ITEM		SPECIFICATIONS
Engine dry weight		18.4 kg (40.5 lbs)
Recommended transmission oil		Pro-Honda HP Trans Oil, Pro-Honda GN4 4-stroke Oil or equivalent motor oil API service classification SF or SG Viscosity : SAE 10W-40
Transmission oil capacity	at draining	0.57 liter (0.60 US qt, 0.50 Imp qt)
	at disassembly	0.65 liter (0.69 US qt, 0.57 Imp qt)
Recommended antifreeze		Pro Honda HP Coolant or an equivalent high quality ethylene glycol antifreeze containing corrosion protection inhibitors
Coolant capacity	at draining	0.88 liter (0.930 US qt, 0.774 Imp qt)
	at disassembly	0.97 liter (1.025 US qt, 0.854 Imp qt)

TORQUE VALUES

Engine hanger plate nut	34 N•m (3.5 kgf•m, 25 lbf•ft)
Engine mount nut	54 N•m (5.5 kgf•m, 40 lbf•ft)
Exhaust pipe joint nut	12 N•m (1.2 kgf•m, 9 lbf•ft)
Swingarm pivot nut	88 N•m (9.0 kgf•m, 65 lbf•ft)
Alternator cover screw	2 N•m (0.2 kgf•m, 1.4 lbf•ft)
Brake pedal pivot bolt	26 N•m (2.6 kgf•m, 19 lbf•ft)
Rear brake reservoir hose guide bolt	10 N•m (1.0 kgf•m, 7 lbf•ft)
Front chamber stay bolt	12 N•m (1.2 kgf•m, 9 lbf•ft)

ENGINE REMOVAL

Remove the springs, bolts and expansion chamber.

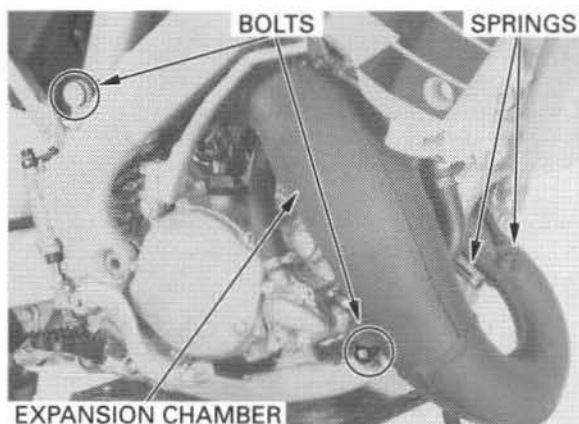

Remove the bolts and exhaust pipe joint.

Drain the transmission oil (page 3-9).

Drain the coolant (page 5-5).

Remove the fuel tank (page 2-5).

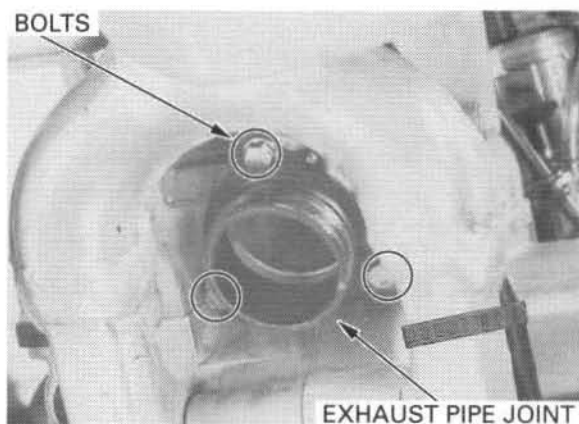

Disconnect the engine stop switch connectors.

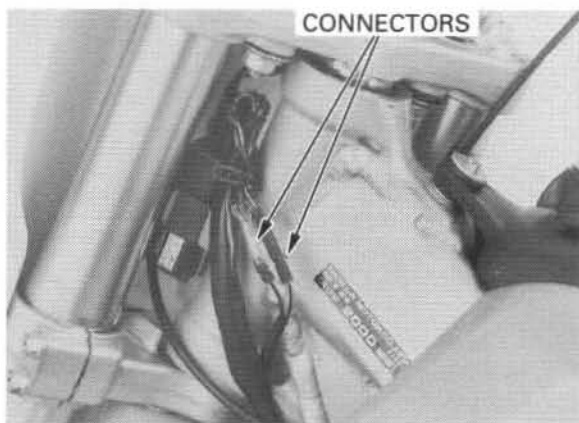

Remove the number plate (page 2-3).

Disconnect the ignition control module connector.

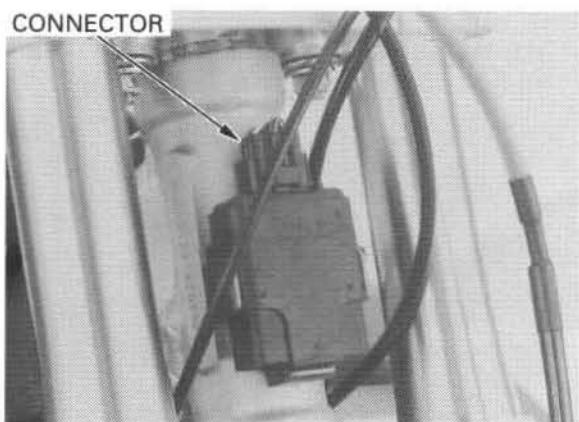

Disconnect the ignition coil connector and ground cable eyelet.

2000 – 2001 Shown:
GROUND CABLE

After 2001 Shown:
CONNECTOR

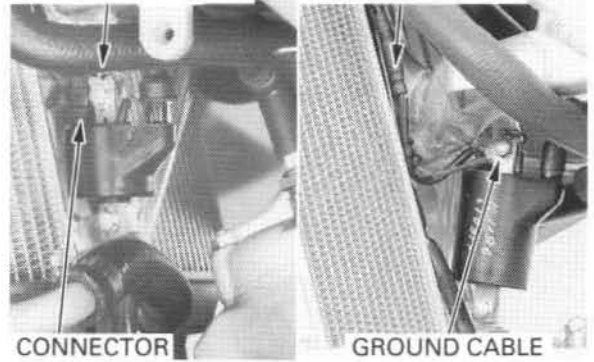

Remove the brake pedal (page 13-20).

Disconnect the radiator hoses.

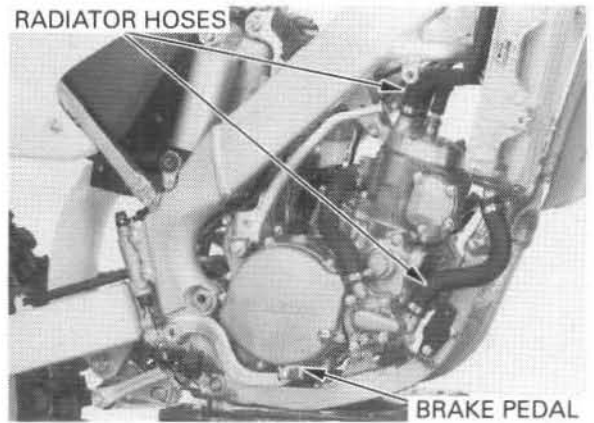

Remove the following:

- Carburetor (page 4-9)
- Wire band
- Spark plug cap
- Drive chain

Remove the alternator cover and disconnect the clutch cable.

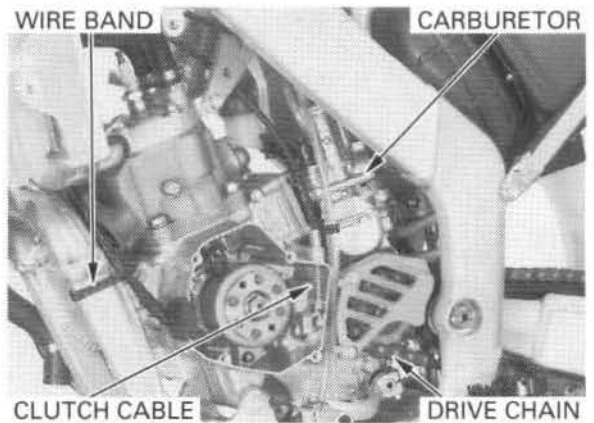

Remove the bolts, nuts, washer, rear brake reservoir bracket (2000 – 2001:) and engine hanger plates.

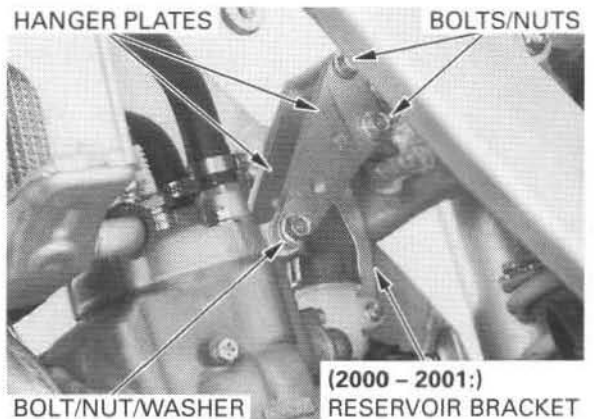

ENGINE REMOVAL/INSTALLATION

Remove the rear brake reservoir hose guide.
Remove the engine mounting bolts, nuts and washers.
Remove the swingarm pivot bolt and nut.

Note the direction of the engine mounting bolts, hanger plate bolts and swingarm pivot bolt.

Remove the engine from the frame.

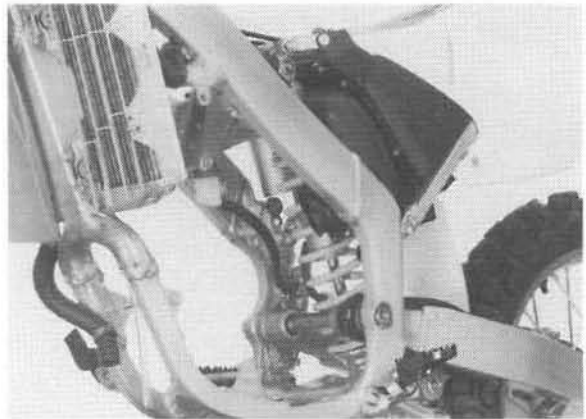
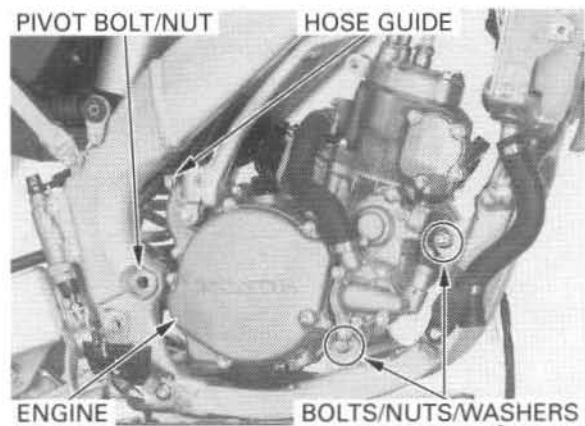

ENGINE INSTALLATION

NOTE:

- Install the swingarm pivot bolt first, then install the engine mounting bolts.
- Route the wires and cables properly (page 1-18).
- Do not tighten the swingarm pivot nut and engine mounting nuts yet.

Install the engine to the frame.
Install the swingarm pivot bolt and nut.
Install the engine mounting bolts and nuts.
Install the rear brake reservoir hose guide.

TORQUE: 10 N•m (1.0 kgf•m, 7 lbf•ft)

Install the engine hanger plates, bolts and nuts.
Tighten the engine mounting nuts, engine hanger plate nuts and swingarm pivot nut to the specified torque.

TORQUE:

ENGINE MOUNT NUT:

54 N•m (5.5 kgf•m, 40 lbf•ft)

ENGINE HANGER PLATE NUT:

34 N•m (3.5 kgf•m, 25 lbf•ft)

SWINGARM PIVOT NUT:

88 N•m (9.0 kgf•m, 65 lbf•ft)

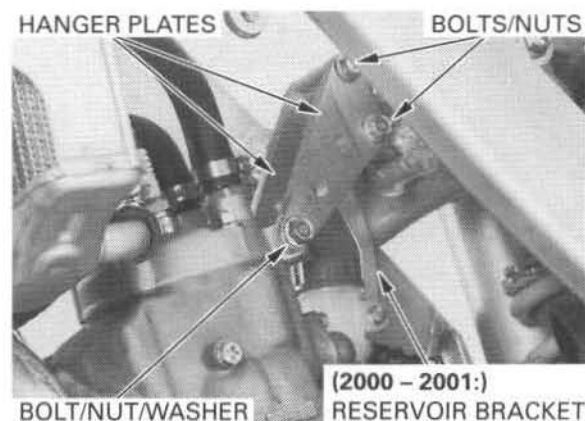
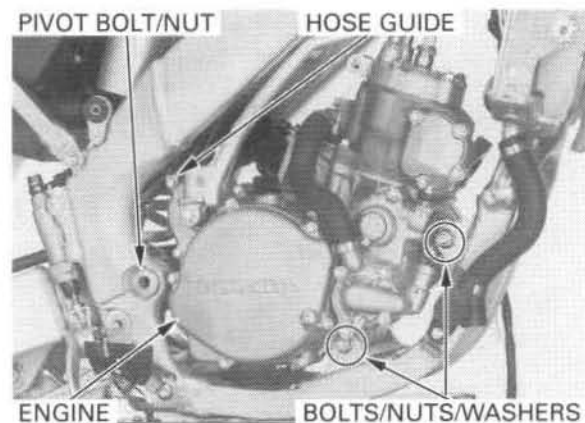

2000:
Install the exhaust pipe joint and tighten the bolts to the specified torque.

TORQUE: 12 N·m (1.2 kgf·m, 9 lbf·ft)

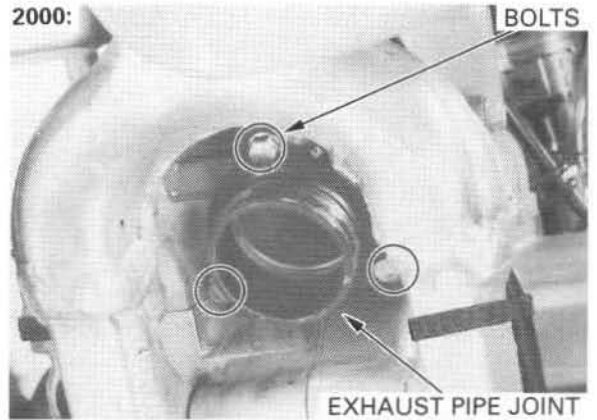

After 2000:
Install the exhaust pipe joint.
Align the top of exhaust port and the top of exhaust pipe joint as shown in the illustration.

Tighten the bolts to the specified torque.

TORQUE: 12 N·m (1.2 kgf·m, 9 lbf·ft)

Apply grease to the new O-ring and install it to the exhaust pipe joint.
Apply grease to the exhaust pipe joint outer surface.

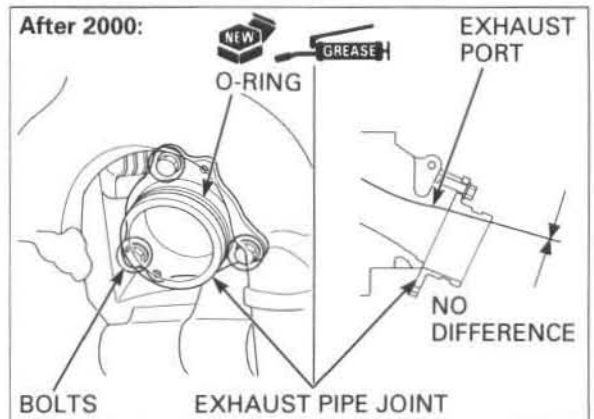

Always install a new gasket and O-ring at the exhaust chamber installation.

Install the exhaust chamber (page 2-7).

Install the removed parts in the reverse order of removal.

Fill the transmission with recommended oil to the correct level (page 3-9).
Pour radiator coolant mixture into the radiator up to the correct level (page 5-4).

After installing the engine, perform the following inspections and adjustments:

- Throttle grip free play adjustment
- Rear brake pedal height
- Drive chain slack
- Clutch lever free play

Check that exhaust gas is not leaking past the expansion chamber connection.

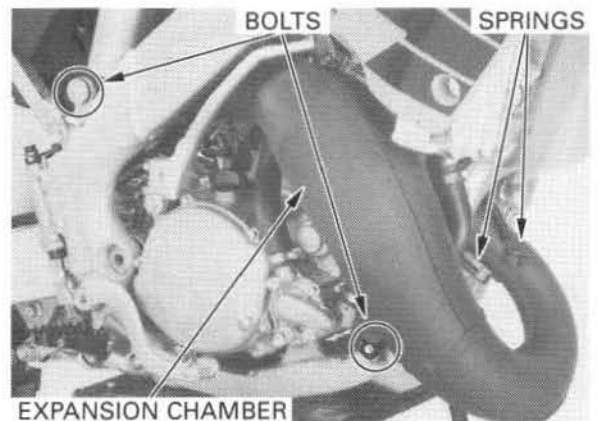

7. CYLINDER HEAD/CYLINDER/PISTON

SERVICE INFORMATION	7-1	CYLINDER HEAD	7-3
TROUBLESHOOTING	7-2	CYLINDER, PISTON	7-5

SERVICE INFORMATION

GENERAL

- This section covers service of the cylinder head, cylinder and piston. These procedures can be done with the engine in the frame.
- Before disassembling, clean the engine thoroughly to keep dirt from entering the engine.
- Do not use a screwdriver to remove the cylinder head.
- Clean all disassembled parts with cleaning solvent and dry them by blowing them off with compressed air before inspection.
- Before assembling, apply clean Pro-Honda HP2 2-stroke Oil to all sliding surfaces.
- Under racing conditions, the piston and piston rings should be replaced after 7.5 hours of running. Replace the piston pin and connecting rod small end bearing after 22.5 hours of running.
- Refer to section 4 for reed valve servicing.
- Refer to section 8 for RC valve system decarbonizing, disassembly and assembly.

SPECIFICATIONS

Unit: mm (in)

ITEM		STANDARD	SERVICE LIMIT
Cylinder head warpage		—	0.05 (0.002)
Cylinder	I.D.	A	53.976 – 53.983 (2.1250 – 2.1253)
		B	53.968 – 53.976 (2.1247 – 2.1250)
	Out of round		—
	Taper		—
	Warpage		—
Piston, piston rings	Piston mark direction		"IN" mark facing toward the intake side
	Piston O.D.	A	53.933 – 53.940 (2.1233 – 2.1236)
		B	53.925 – 53.933 (2.1230 – 2.1233)
	Piston O.D. measurement point		15 mm (0.59 in) from bottom of skirt
	Piston pin bore I.D.		15.002 – 15.015 (0.5906 – 0.5911)
	Piston pin O.D.		14.994 – 15.000 (0.5903 – 0.5906)
	Piston-to-piston pin clearance		0.002 – 0.021 (0.0001 – 0.0008)
	Piston ring-to-ring groove clearance		0.045 – 0.080 (0.002 – 0.003)
Piston ring end gap		0.40 – 0.55 (0.016 – 0.022)	
Cylinder-to-piston clearance		0.035 – 0.050 (0.0014 – 0.0020)	
Connecting rod small end I.D.		19.002 – 19.014 (0.7481 – 0.7486)	

CYLINDER HEAD/CYLINDER/PISTON

TORQUE VALUES

Cylinder head nut	27 N•m (2.8 kgf•m, 20 lbf•ft)
Cylinder mounting nut	27 N•m (2.8 kgf•m, 20 lbf•ft)
Cylinder stud bolt	12 N•m (1.2 kgf•m, 9 lbf•ft)
Exhaust pipe joint bolt	12 N•m (1.2 kgf•m, 9 lbf•ft)
Cylinder sealing bolt	10 N•m (1.0 kgf•m, 7 lbf•ft)
Engine hanger plate bolt	34 N•m (3.5 kgf•m, 25 lbf•ft)
RC valve cover bolt	12 N•m (1.2 kgf•m, 9 lbf•ft)
RC valve cover screw	3 N•m (0.3 kgf•m, 2.2 lbf•ft)

TROUBLESHOOTING

- Engine top-end problems usually affect engine performance. These problems can be diagnosed by a compression test or by tracing engine noises to the top-end with a sounding rod stethoscope.
- If the performance is poor at low speeds, check for white smoke in the crankcase breather tube. If the tube is smoky, check for a seized piston ring.

Compression too low, hard starting or poor performance at low speed

- Blown cylinder head gasket
- Loose spark plug
- Worn, stuck or broken piston ring
- Worn or damaged cylinder and piston
- Faulty reed valve
- Worn crankshaft seals

Abnormal noise – piston ring

- Worn, stuck or broken piston ring
- Worn or damaged cylinder

Contaminated coolant

- Leaking cylinder head gasket

Compression too high, overheating or knocking

- Excessive carbon build-up on top of piston or in combustion chamber

Abnormal noise – piston

- Worn or cracked piston
- Worn cylinder and piston
- Worn piston pin or piston pin hole
- Worn connecting rod small end bearing

CYLINDER HEAD

REMOVAL

Drain the radiator coolant (page 5-4).
Remove the seat and fuel tank (page 2-2, 5).

⚠ WARNING

- Gasoline is extremely flammable and is explosive under certain conditions.
- Work in a well ventilated area with the engine stopped.
- Do not smoke or allow flames or sparks in the work area or where gasoline is stored.

Note the direction of the hose clamp.

Loosen the radiator hose clamps and remove the radiator hoses from the cylinder head.

Remove the spark plug cap and spark plug.

Remove the engine upper hanger plate bolts and hanger plates.

Remove the five cylinder head nuts.

CAUTION:

To avoid warping the cylinder head, use a crisscross pattern to loosen each nut about 1/4 turn in two or three steps, then remove the nuts.

Remove the cylinder head.

Remove the cylinder head gasket.
Remove the dowel pins.

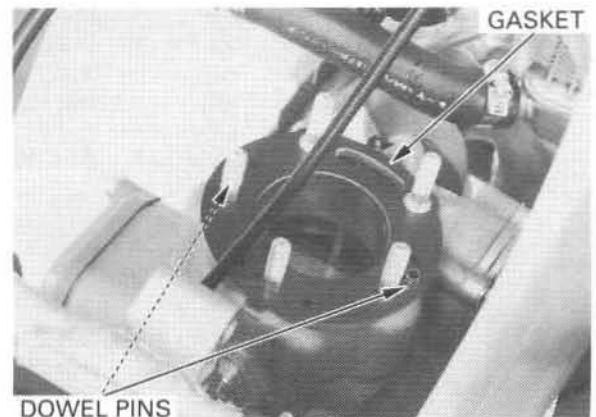
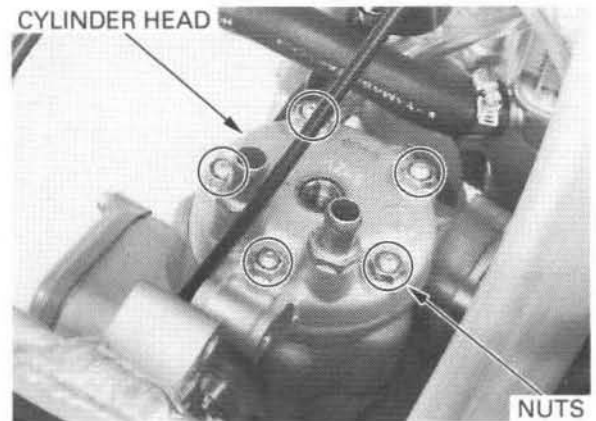
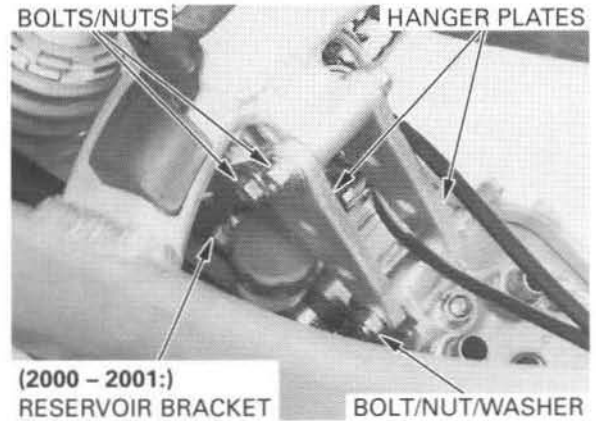
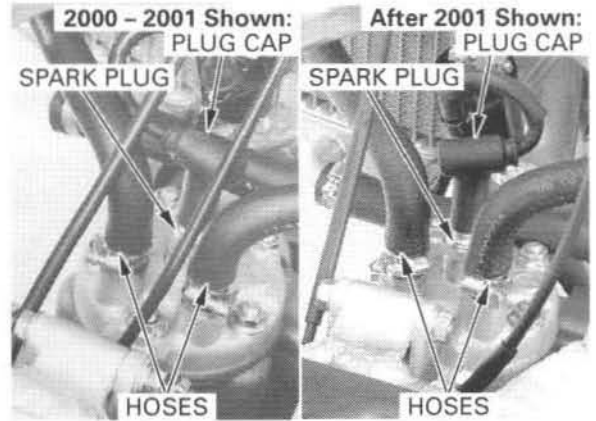

CYLINDER HEAD/CYLINDER/PISTON

INSPECTION

Be careful not to damage the cylinder head.

Clean the head gasket surface of any gasket material. Remove the carbon deposits from the combustion chamber.

Check the cylinder head for warpage in diagonal directions using a straight edge and feeler gauge.

SERVICE LIMIT: 0.05 mm (0.002 in)

CYLINDER HEAD

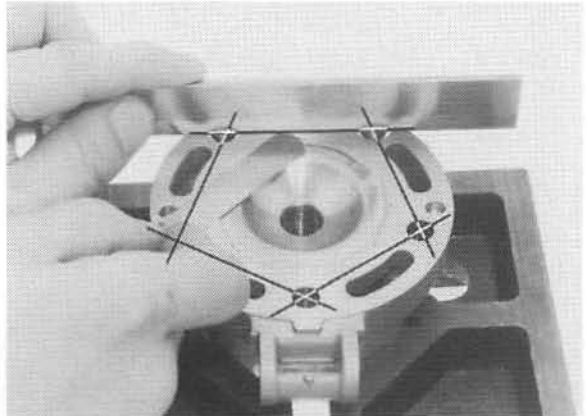
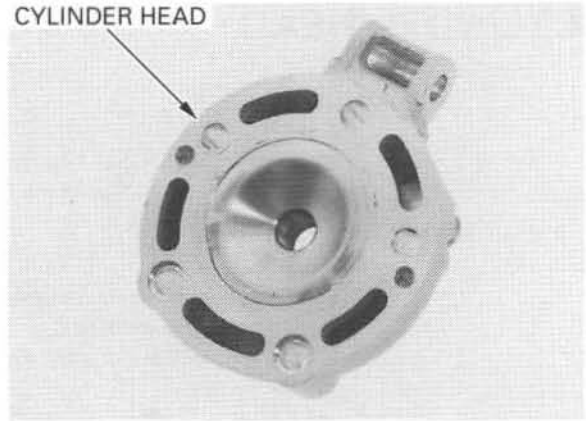

INSTALLATION

Install the dowel pins.
Install the new cylinder head gasket with the "UP" mark facing up and tab to the rear.

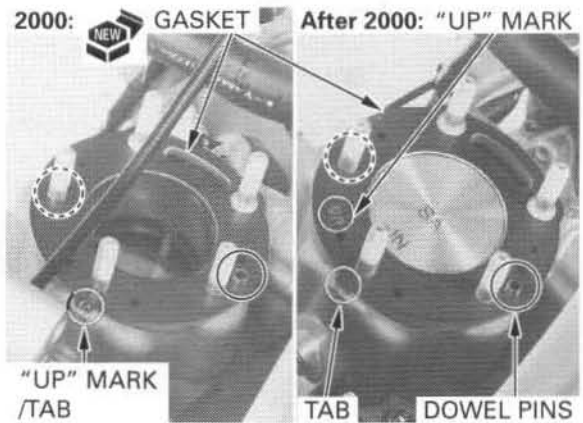

Place the cylinder head on the cylinder.
Install the five cylinder head nuts in a crisscross pattern in two or three steps.
Then tighten the nuts to the specified torque.

TORQUE: 27 N·m (2.8 kgf·m, 20 lbf·ft)

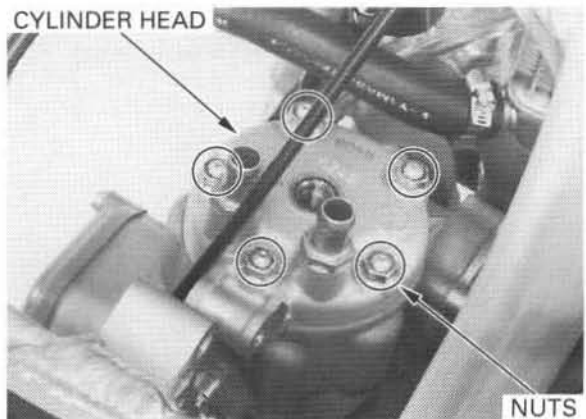

Install the washer with the rounded edge facing engine hanger plate side.

Install the engine upper hanger brackets, rear brake reservoir bracket (2000 – 2001:), bolts, nuts and washer.

Tighten the mounting nuts to the specified torque.

TORQUE: Engine hanger plate bolt:
34 N•m (3.5 kgf•m, 25 lbf•ft)

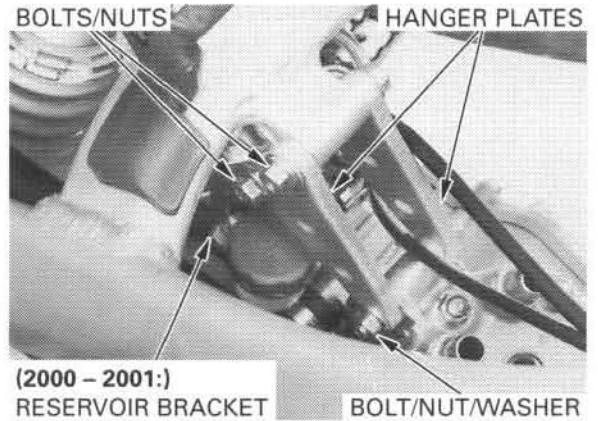

Install the spark plug and spark plug cap.

Note the direction of the hose clamp.

Connect the radiator hose to the cylinder head.

Add the recommend coolant mixture into the radiator up to the correct level (page 5-3).

Install the fuel tank and seat (page 2-2, 5).

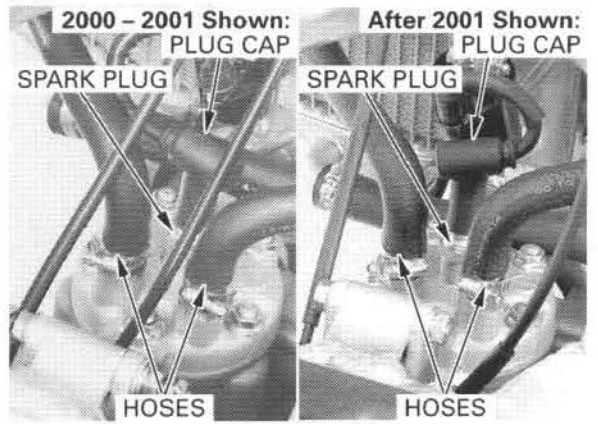

CYLINDER, PISTON

CYLINDER REMOVAL

Remove the cylinder head (page 7-3).
 Remove the expansion chamber (page 2-7).

Loosen the water hose clamp screws at the cylinder and remove the hose.

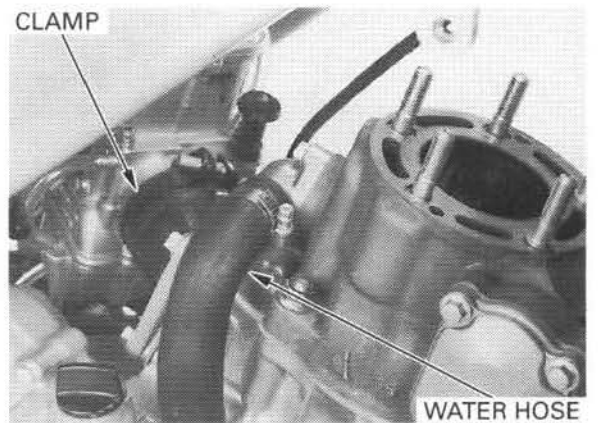

- Remove the following:
- RC valve cover screw and bolts
 - RC valve cover
 - Gasket and grommet
 - Pinion rod

NOTE:

- Be careful not to drop the B-clip and collar into the right crankcase cover.
- If cylinder replacement is required, remove the RC valve system.

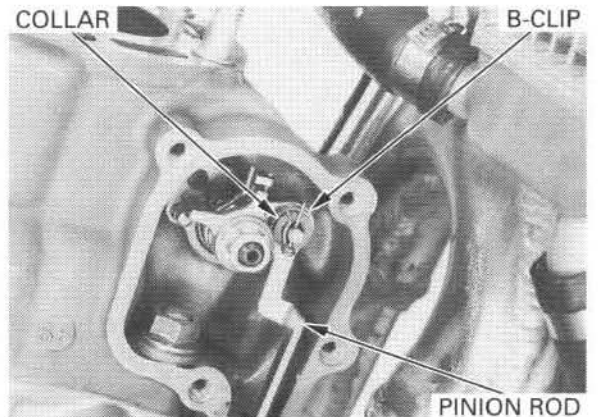

CYLINDER HEAD/CYLINDER/PISTON

Remove the alternator cover (page 14-8).
Rotate the flywheel counterclockwise until the piston is at TDC.

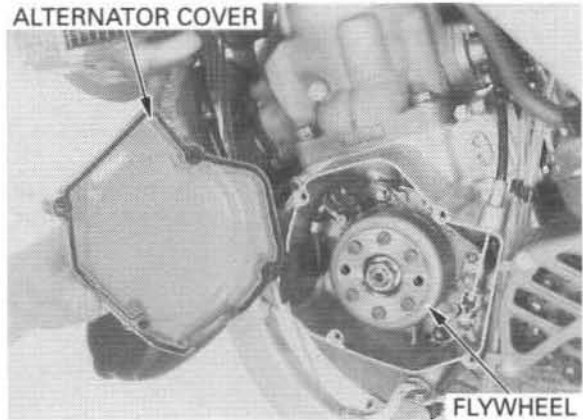

Loosen the cylinder nuts in a crisscross pattern in two or three steps.

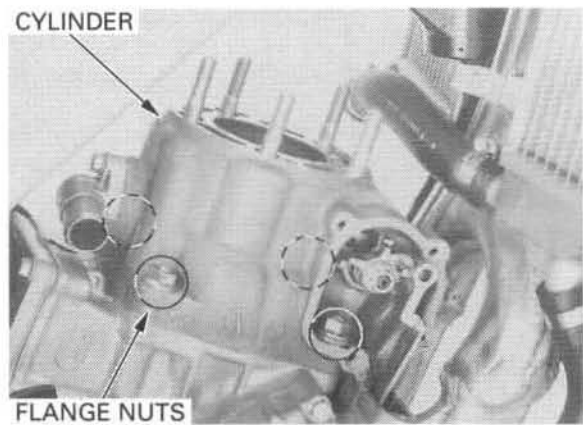

Remove the cylinder, gasket and dowel pins.

Remove the RC valve system (page 8-4).
Remove the exhaust pipe joint (page 6-2).

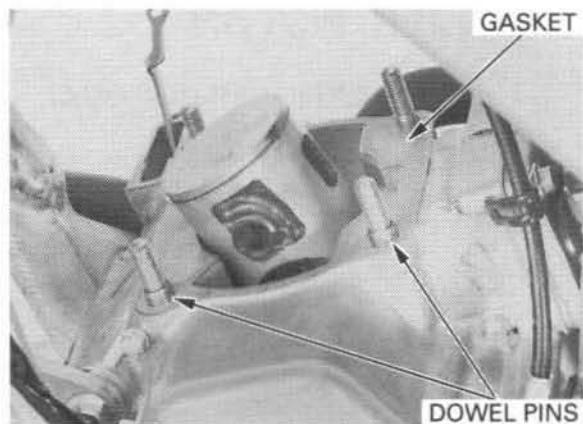

PISTON REMOVAL

NOTE:

- Do not let the clips fall into the crankcase.
- Always support the piston when pressing out the pin.

Remove the piston pin clip, piston pin and piston.

NOTE:

Under racing conditions, the piston and piston ring should be replaced according to the maintenance schedule. See page 3-3.

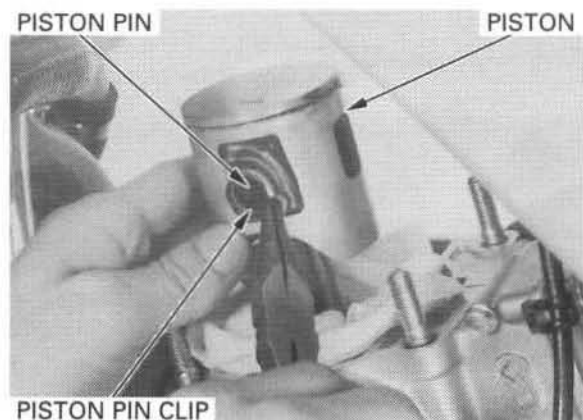

Do not damage the piston rings by spreading the ends too far.

Spread the piston ring and remove by lifting it up at a point just opposite the gap.

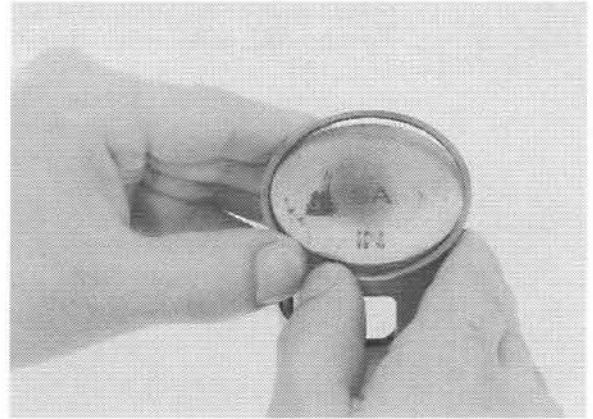

CYLINDER INSPECTION

Remove the carbon deposits from the exhaust port area.

CAUTION:

Do not damage the cylinder bore.

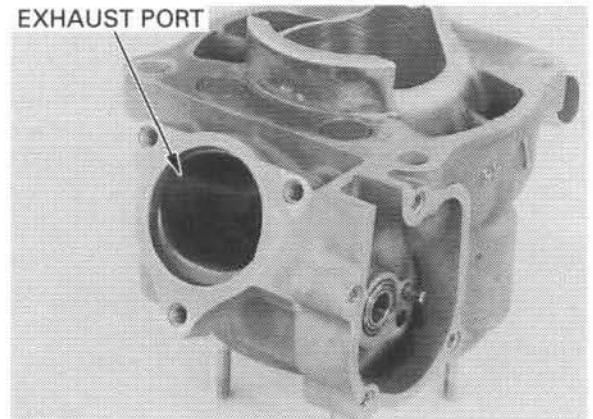

Inspect the top of the cylinder for warpage.

Use a straight edge and feeler gauge to check the head gasket surface on the cylinder for warpage.

If warpage is beyond the service limit, correct as necessary.

SERVICE LIMIT: 0.05 mm (0.002 in)

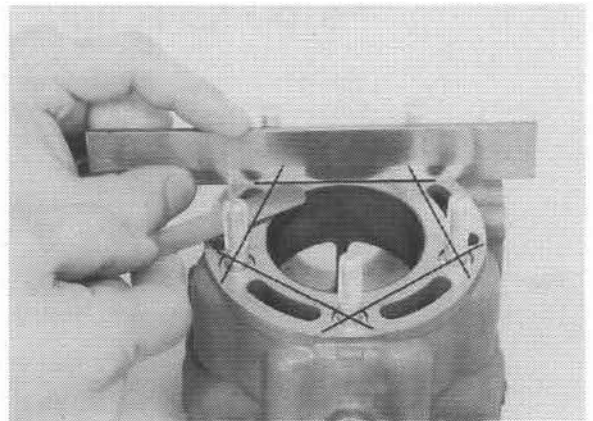

Check that the cylinder studs are tight. If any are loose, remove them, clean their threads with contact cleaner, then install them using Honda Anaerobic Thread Lock or equivalent. Tighten the stud bolts to the specified torque.

TORQUE: 12 N·m (1.2 kgf·m, 9 lbf·ft)

If necessary, remove the bolts and water hose joint from the cylinder. Discard the O-ring and install a new one. Install the water hose joint in the reverse order of removal.

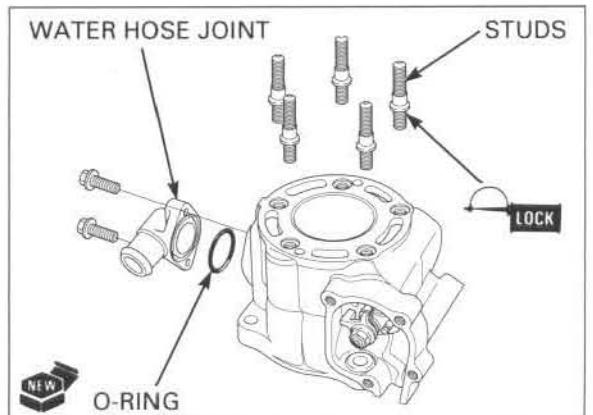

CYLINDER HEAD/CYLINDER/PISTON

Measure the bore diameter at four positions, top, middle (A), middle (B) and bottom.

With the exception of the bottom, measure both "X" and "Y" axis at each position. Measure only the "X" axis of the bottom position.

TOP: 5 mm (0.2 in)
MIDDLE (A): 20 mm (0.8 in)
MIDDLE (B): 70 mm (2.8 in)
BOTTOM: 90 mm (3.5 in)

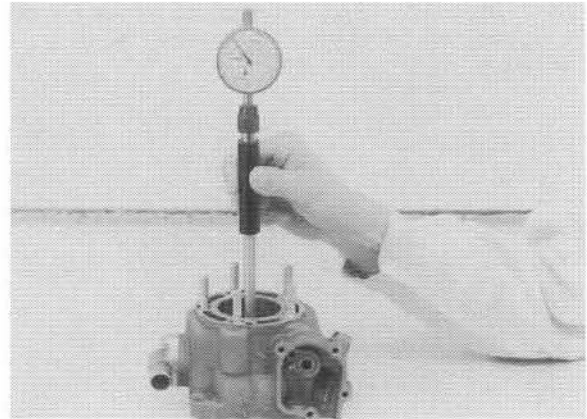

Use large figure measured to determine the cylinder wear.

SERVICE LIMITS: A : 54.013 mm (2.1265 in)
B : 54.006 mm (2.1262 in)

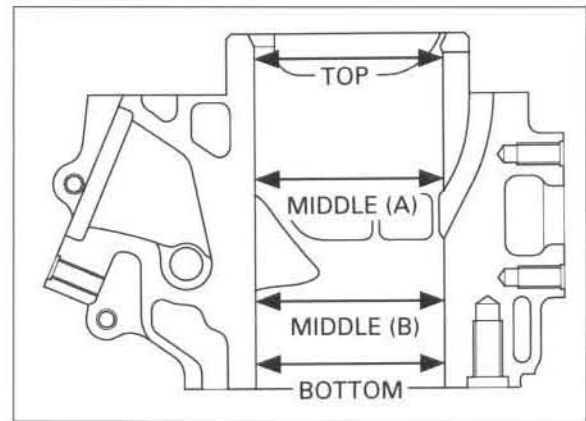

PISTON INSPECTION

Measure the piston O.D. 10 mm (0.39 in) from the bottom of the skirt and at a right angle to the piston pin hole.

SERVICE LIMITS: A : 53.883 mm (2.1214 in)
B : 53.875 mm (2.1211 in)

If the O.D. is under the service limit or if nearly 7.5 hours of running time have elapsed, replace the piston with a new one.

Calculate the cylinder-to-piston clearance.

SERVICE LIMIT: 0.07 mm (0.003 in)

Remove the carbon deposits from the the piston ring grooves.

Measure the piston ring-to-groove clearance.

SERVICE LIMIT: 0.09 mm (0.004 in)

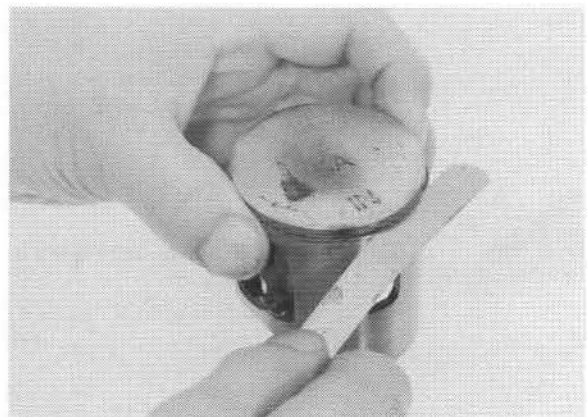
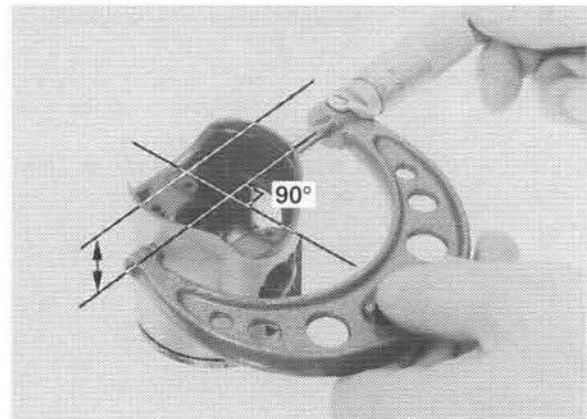

Measure the piston pin bore I.D.

SERVICE LIMIT: 15.035 mm (0.5919 in)

Check the piston pin for wear and excessive discoloration.

Measure the piston pin O.D.

SERVICE LIMIT: 14.98 mm (0.590 in)

If the O.D. is under the service limit, discolored, or nearly 22.5 hours of running time have elapsed, replace the piston pin and bearing.

Calculate the piston pin-to-piston clearance.

SERVICE LIMIT: 0.03 mm (0.001 in)

Insert the piston ring into the cylinder to distance from the cylinder bottom shown.

Use the piston to push the ring squarely into the cylinder.

Measure the piston ring end gaps with the feeler gauge.

SERVICE LIMIT: 0.65 mm (0.026 in)

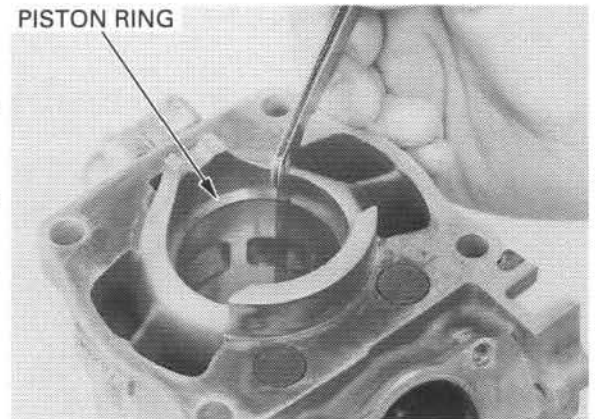
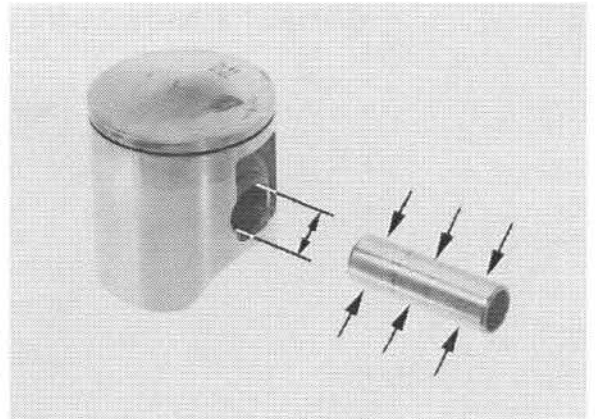

CYLINDER/PISTON SELECTION

The cylinders and pistons are select fitted.

Record the piston O.D. code letter (A or B).

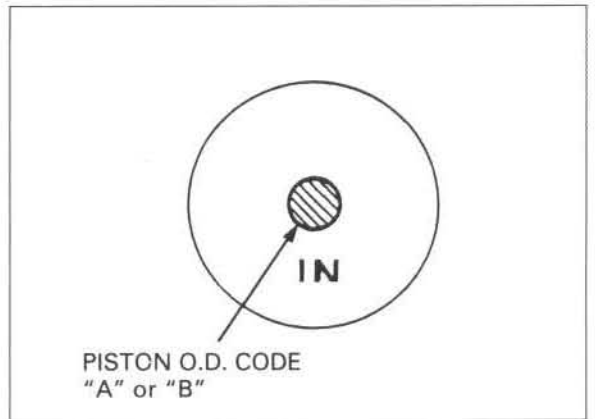

Record the cylinder I.D. code letter (A or B).

Use new cylinders and pistons with the same I.D. and O.D. codes when replacing the cylinder and/or piston.

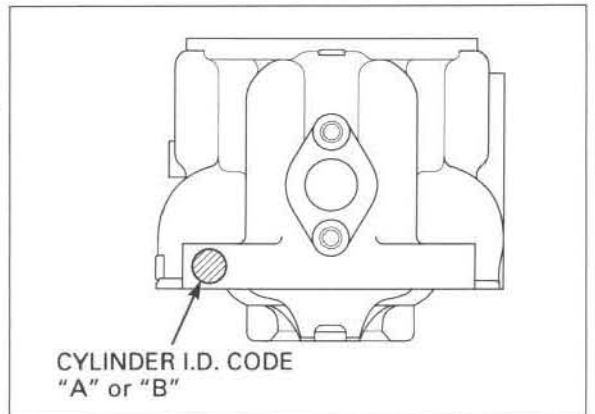

CONNECTING ROD INSPECTION

Install the needle bearing and piston pin in the connecting rod small end and check it for excessive play.

PISTON PIN/NEEDLE BEARING

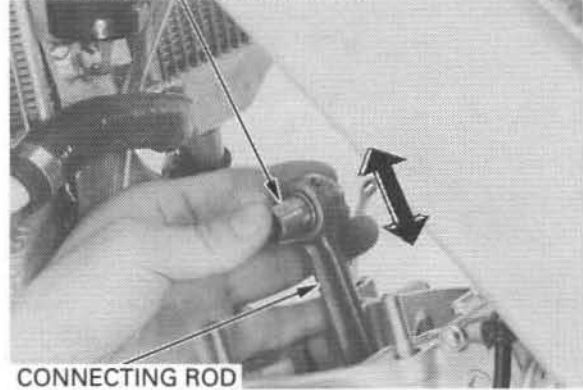

If it feels loose, measure the connecting rod small end I.D.

SERVICE LIMIT: 19.022 mm (0.7489 in)

If the I.D. is over the service limit, replace the piston pin and bearing.
If the I.D. is not over the service limit, replace the crankshaft (page 10-8).

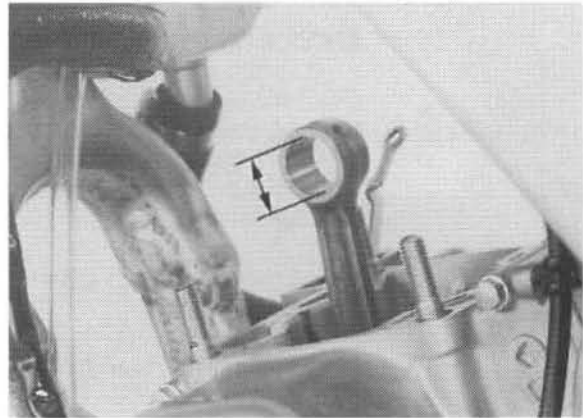

PISTON INSTALLATION

Clean the piston ring grooves.

Lubricate the piston ring and piston ring groove with clean Pro-Honda HP2 2-stroke oil.

Install the piston ring on the piston with the mark facing up.

Locate the ring end gap on the pin in the piston ring groove.

MARK

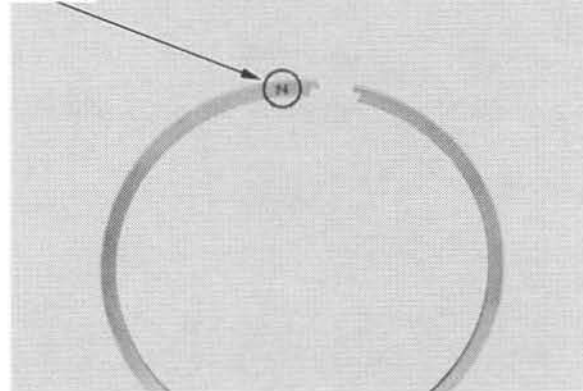

Be careful not to remove any material from the gasket surface.

Clean off any gasket material from the cylinder surface.

Lubricate the small end bearing and piston pin with clean Pro-Honda HP2 2-stroke oil.

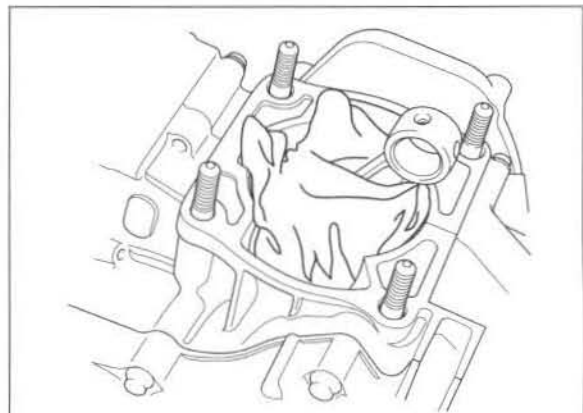

Install the connecting rod small end bearing, piston and piston ring.

NOTE:

Install the piston with the "IN" mark facing the intake side. If the "IN" mark is obliterated, install the piston with the hole facing the intake side.

Install the new piston pin clips in the groove on the position.
Do not align the piston pin clip end gap with the piston cut-out.

CAUTION:

- Use new piston pin clips. Never reuse old clips.
- Do not let the piston pin clips fall into the crankcase.

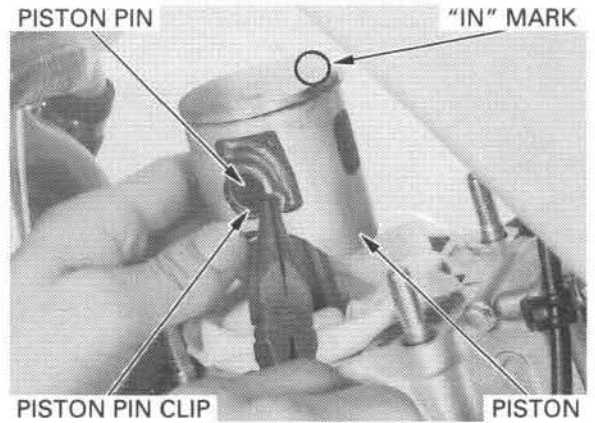

CYLINDER INSTALLATION

Install the RC valve system to the cylinder (page 8-4).
Install the exhaust pipe joint to the cylinder (page 6-5).

Align the ring end gap with the piston ring pin.

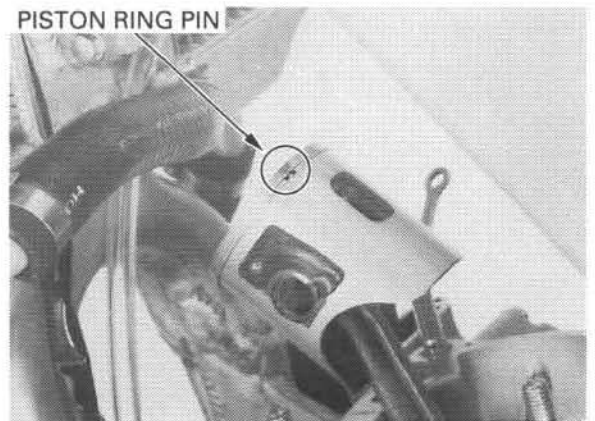

Place the dowel pins and new base gasket on the crankcase.

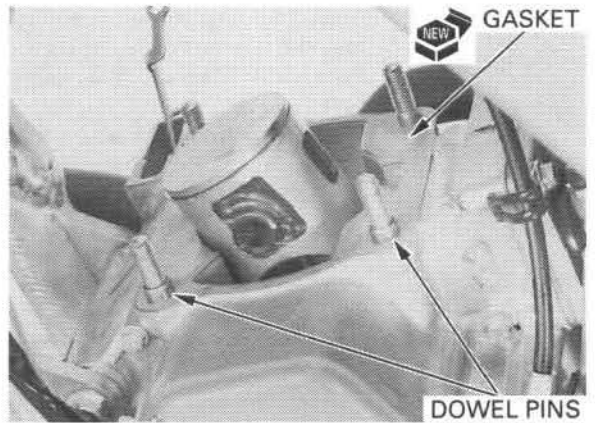

Lubricate the piston with Pro-Honda HP2 2-stroke Oil and slip the cylinder over the piston while compressing the piston ring.

CAUTION:

Do not rotate the cylinder, since this may cause the piston ring to snag a cylinder port and break.

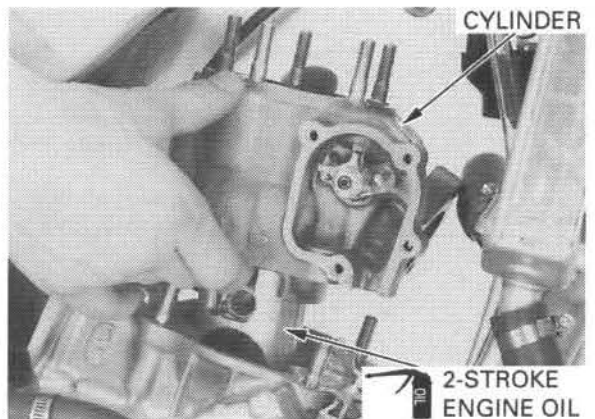

CYLINDER HEAD/CYLINDER/PISTON

Install the cylinder onto the crankcase.

NOTE:

Before tightening the cylinder nuts, be sure the cylinder is seated completely against the crankcase.

Install and tighten the four cylinder nuts in a crisscross pattern in two or three steps.

TORQUE: 27 N•m (2.8 kgf•m, 20 lbf•ft)

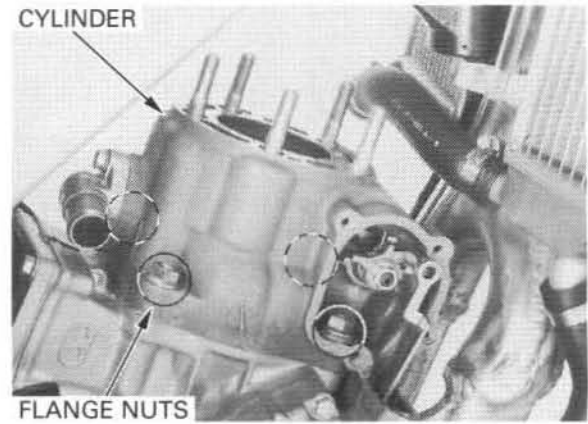

Install the pinion rod by pushing it down and onto the pin.

Attach the rod using the setting collar and B-clip.

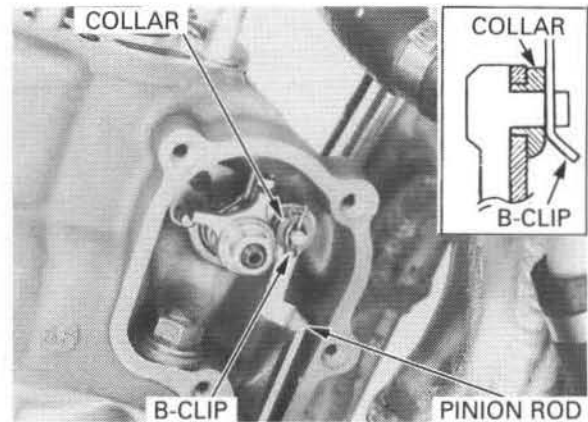

Position the gasket on the RC valve cover.
Install the grommet on the cylinder.
Install the RC valve cover using the four mounting bolts and one screw.
Tighten the bolts and screw to the specified torque.

TORQUE: BOLT: 12 N•m (1.2 kgf•m, 9 lbf•ft)
SCREW: 3 N•m (0.3 kgf•m, 2.2 lbf•ft)

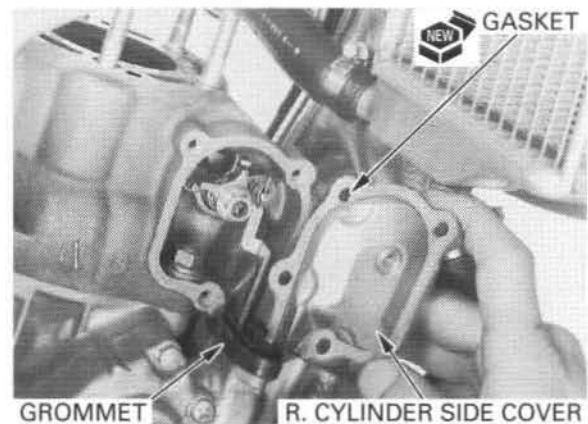

Install the water hose and tighten the hose clamp screw securely.

Install the following:

- Expansion chamber (page 2-7)
- Cylinder head (page 7-4)
- Fuel tank and seat (page 2 -2,5)

Pour the recommended coolant mixture into the radiator up to the correct level (page 5-4).

Check the following:

- Compression leaks
- Abnormal engine noise
- Secondary air leaks
- Coolant leaks

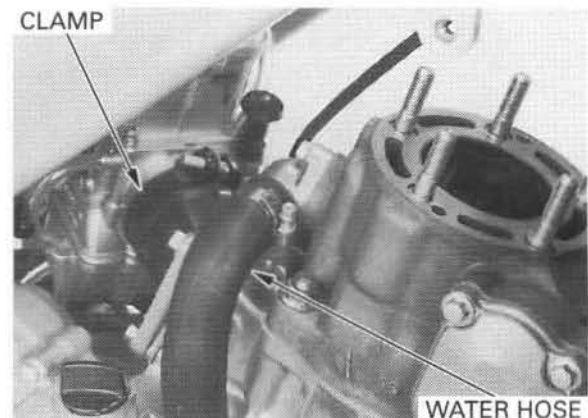

MEMO

RC VALVE

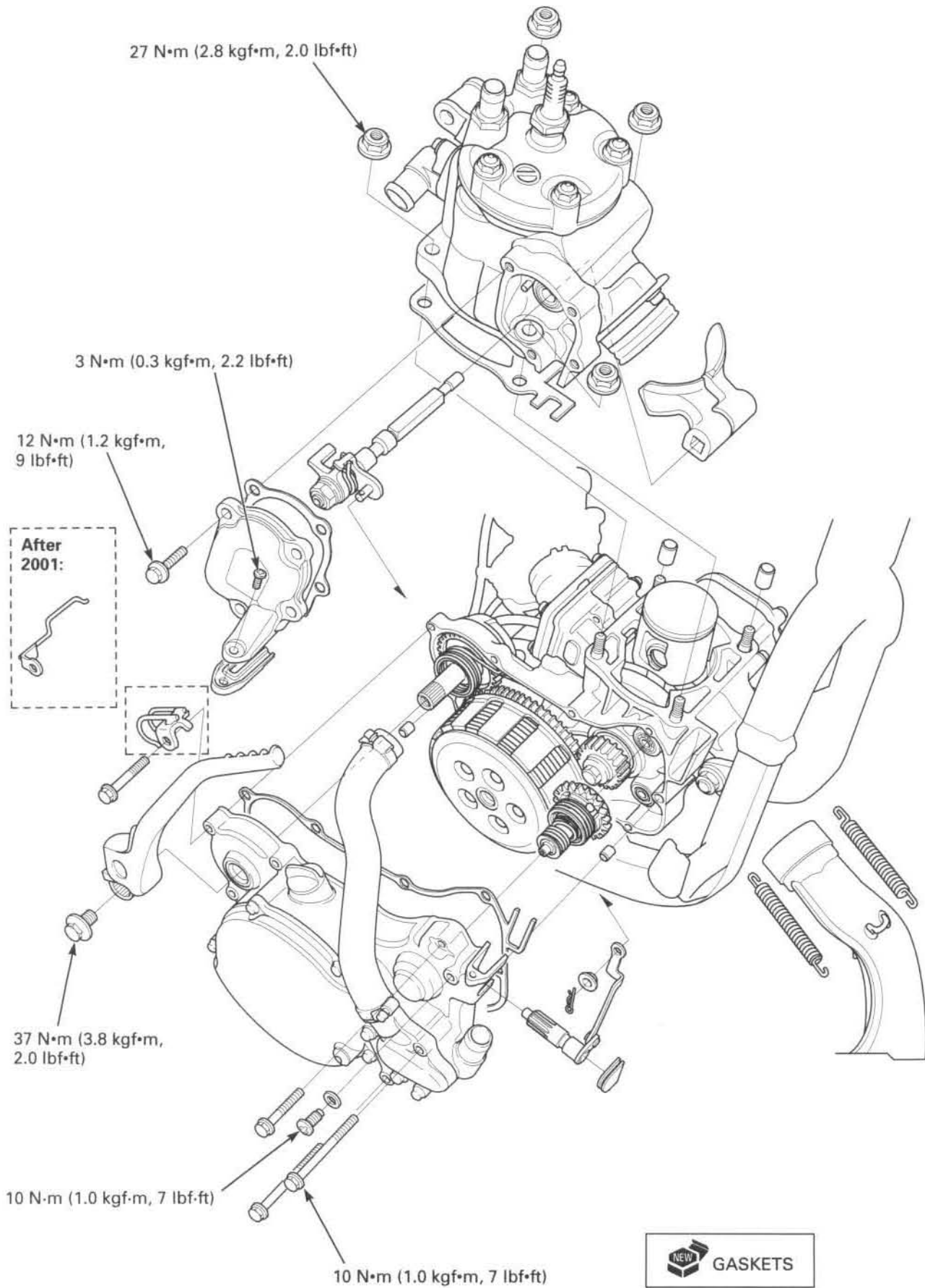

8. RC VALVE

SERVICE INFORMATION	8-1	EXHAUST VALVE	8-2
TROUBLESHOOTING	8-1	GOVERNOR/VALVE LINKAGE	8-5
EXHAUST DEPOSIT DRAINING	8-2		

SERVICE INFORMATION

GENERAL

- This section covers the maintenance of the RC valve.
- Decarbonize the flap valves and valve shaft every 7.5 hours of running (approximately three races).

TORQUE VALUES

Flap valve shaft nut	10 N•m (1.0 kgf•m, 7 lbf•ft)
RC valve cover bolt	12 N•m (1.2 kgf•m, 9 lbf•ft)
RC valve cover screw	3 N•m (0.3 kgf•m, 2.2 lbf•ft)
Blow-by oil drain bolt	10 N•m (1.0 kgf•m, 7 lbf•ft)
RC valve pinion rod setting screw	9 N•m (0.9 kgf•m, 6.5 lbf•ft)

TOOLS

Valve guide driver, 22 mm I.D.	07742 – 0020200	
Bearing remover, 7 mm	07931 – KA30000	Not available in U.S.A.
Bearing driver, 7 mm	07931 – KA30100	Not available in U.S.A.

TROUBLESHOOTING

Poor performance at low speed

- Exhaust valve does not close fully
 - Faulty governor
 - Bent valve shaft
 - Damaged drive shaft bearing
- Excessive carbon build-up on the flap valves and valve shaft
- Damaged flap valves and valve shaft

Poor performance at high speed

- Exhaust valve does not open fully
 - Improper installation
 - Faulty governor
 - Damaged drive shaft bearing
- Excessive carbon build-up on the flap valves and valve shaft
- Damaged flap valves and valve shaft

EXHAUST DEPOSIT DRAINING

Remove the drain bolt and drain the exhaust deposits from the right crankcase cover.

NOTE:

Under racing conditions, drain the exhaust deposits after every 22.5 hours of running.

Install and tighten the drain bolt to the specified torque.

TORQUE: 10 N·m (1.0 kgf·m, 7 lbf·ft)

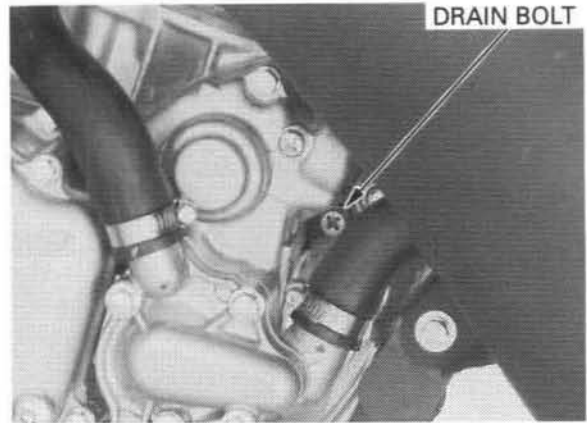

EXHAUST VALVE

REMOVAL/DISASSEMBLY

Remove the cylinder (page 7-3).

Remove the flap valve drive shaft assembly and flap valves from the cylinder.

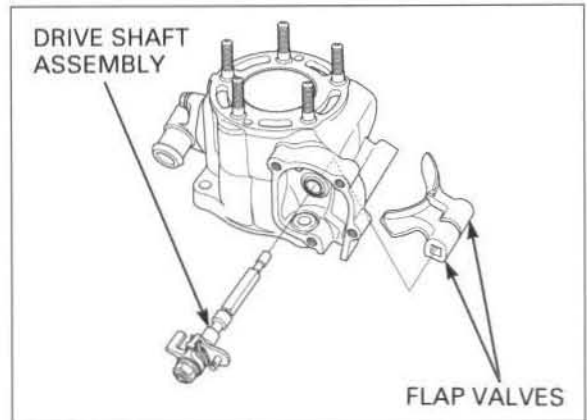

Remove the nut and disassemble the flap valve drive shaft assembly.

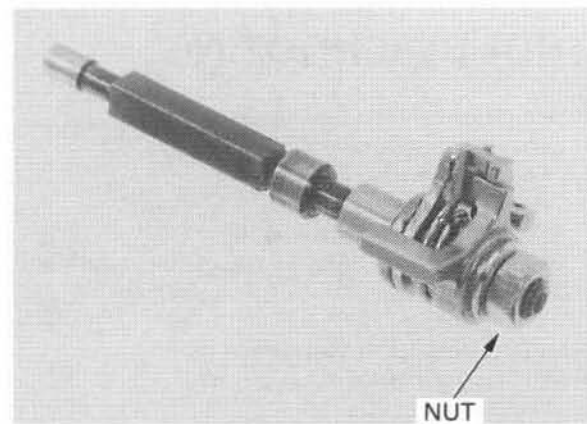

DECARBONIZING/INSPECTION

NOTE:

Replace the flap valves and flap valve drive shaft as a set.

Decarbonize the flap valves each race

Remove the carbon deposits from the flap valves. Inspect the flap valves for wear or damage.

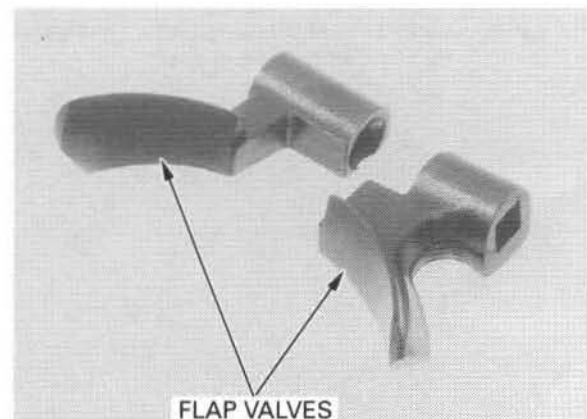

Decarbonize the
drive shaft each
race

Remove the carbon deposits from the flap valve
drive shaft.
Inspect the flap valve drive shaft for wear or damage.

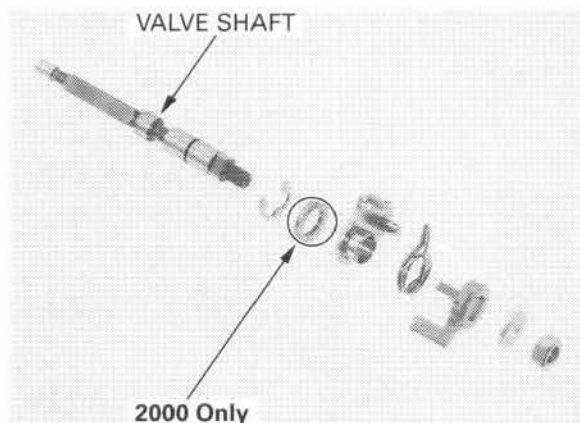

FLAP VALVE DRIVE SHAFT BEARING REPLACEMENT

Remove the bearing by thermally expanding the
cylinder:
Slowly and uniformly heat the cylinder with a heat
gun (industrial dryer).

⚠ WARNING

*To avoid burns, wear insulated gloves when
handling the heated parts.*

CAUTION:

*Using a torch to heat the cylinder may cause
warping*

Drive in a new bearing into the cylinder.

TOOL:

Valve guide driver, 22 mm I.D. 07742-0020200

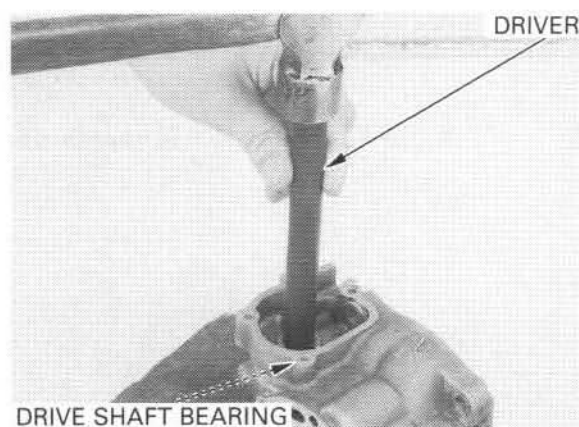
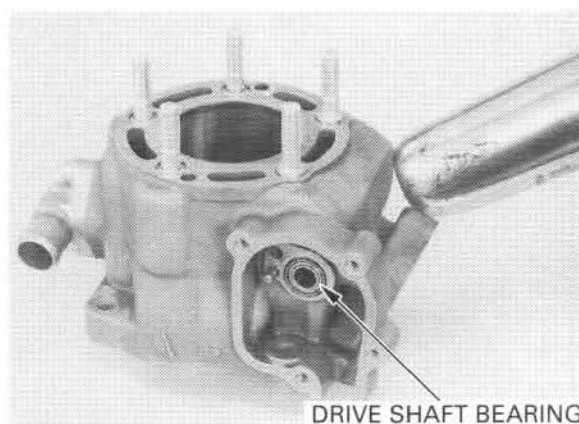

ASSEMBLY/INSTALLATION

Assemble the flap valve drive shaft and tighten the
nut to temporarily.

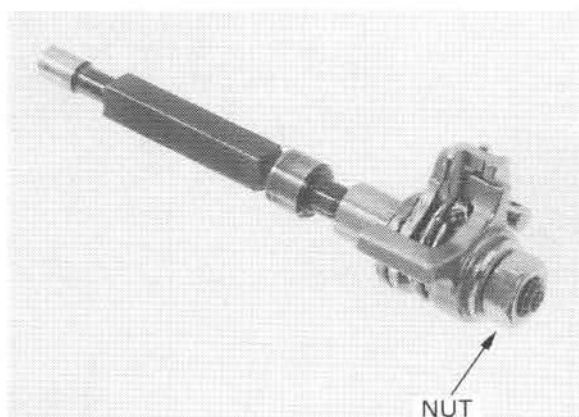

RC VALVE

Apply molybdenum disulfide oil to the drive shaft sliding and rolling surface.

Install the flap valves and flap valve drive shaft assembly into the cylinder.

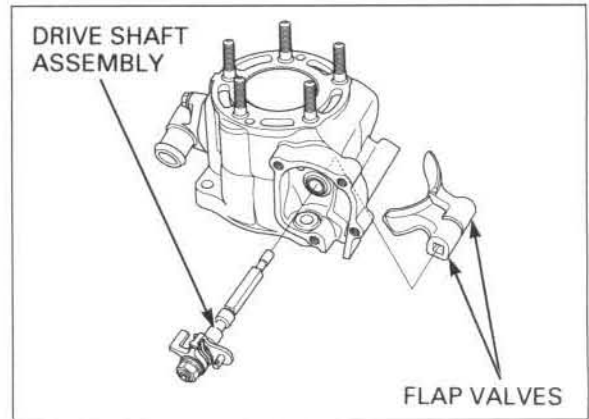

Install the suitable pin into the $\varnothing 5.5$ mm hole on the cylinder.

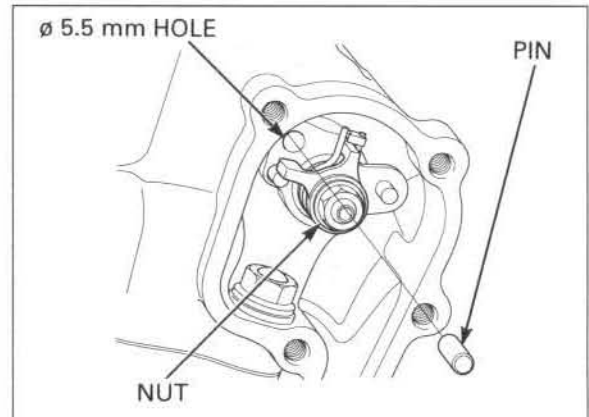

Lift the flap valve with your finger and until the flap valve arm stops seats against the pin.
Tighten the drive shaft nut to the specified torque.

TORQUE: 9 N·m (0.9 kgf·m, 6.5 lbf·ft)

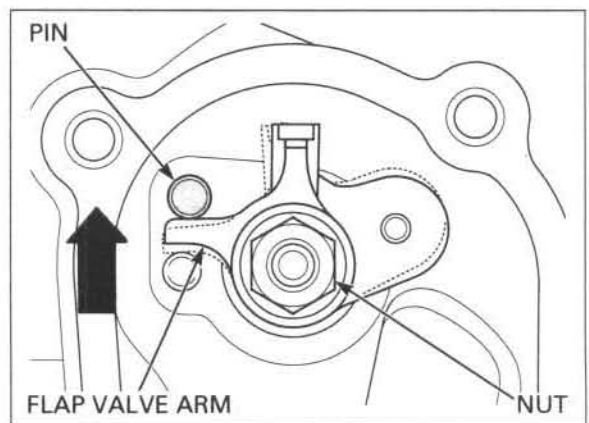

After tighten, measure the cylinder upper surface-to-flap valves lower end clearance is 37.75 ± 0.4 mm (1.486 ± 0.02 in).

Install the cylinder (page 7-11).

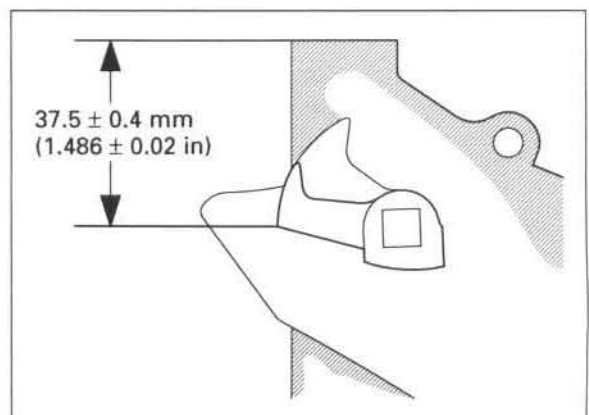

GOVERNOR/VALVE LINKAGE

REMOVAL

Remove the following:

- RC valve cover and link (page 7-5)
- Right crankcase cover (page 9-3)

Remove the pinion gear by removing the retaining screw, washer and grommet.

Remove the governor assembly by pulling it off the shaft.

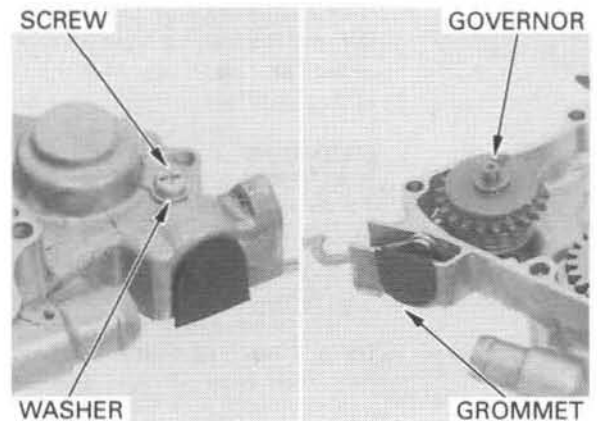

INSPECTION

Inspect the pinion gear teeth for excessive wear or damage.

Inspect the governor gear teeth for excessive wear or damage.

CAUTION:

Do not disassemble the governor.

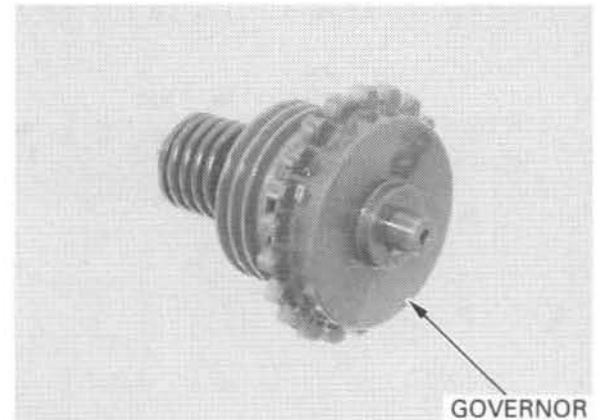

GOVERNOR SHAFT BEARING REPLACEMENT

RIGHT CRANKCASE SIDE:

Remove the bearing using the special tool.

TOOL:

Bearing remover, 7 mm

07931 - KA30000
not available in
U.S.A.

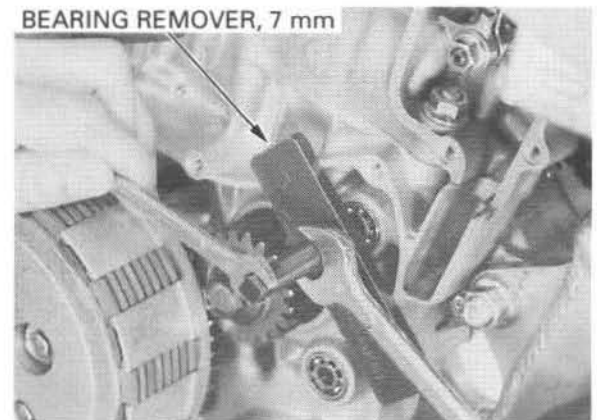

Drive in the new bearing into the right crankcase.

TOOL:

Bearing driver, 7 mm

07946 - KA30100
not available in
U.S.A.

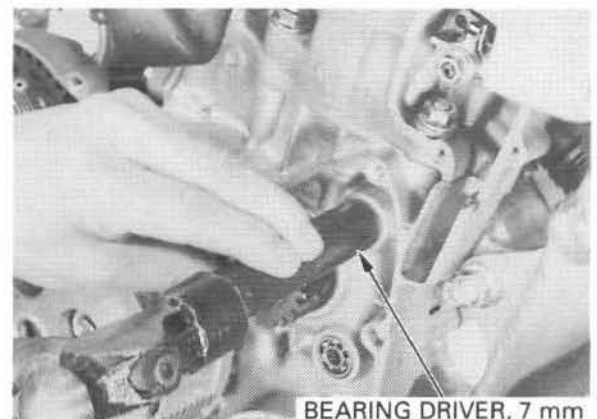

RIGHT CRANKCASE COVER SIDE:

Remove the bearing by thermally expanding the case: Slowly and uniformly heat the case with a heat gun (industrial dryer).

⚠ WARNING

To avoid burns, wear insulated gloves when handling the heated parts.

CAUTION:

Using a torch to heat the case may cause warping.

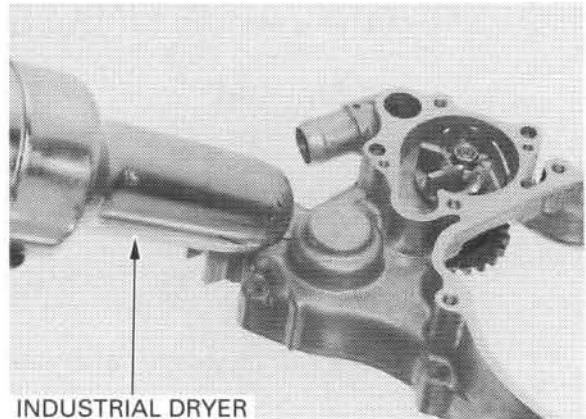

Drive in the new bearing into the right crankcase.

TOOL:

Bearing driver, 7 mm

07931 - KA30100
not available in
U.S.A.

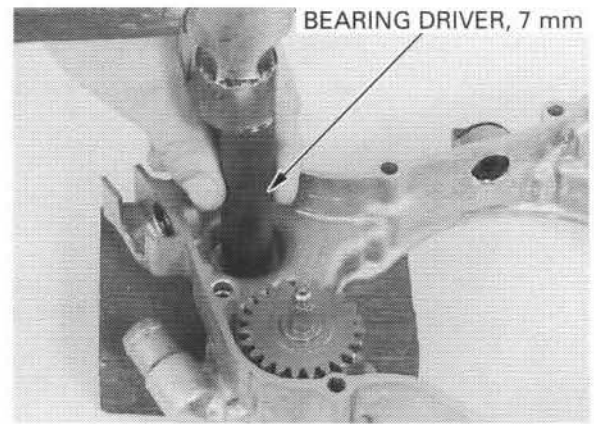

Apply recommended transmission oil to the pinion gear.

Install the pinion gear and retaining screw with its washer.

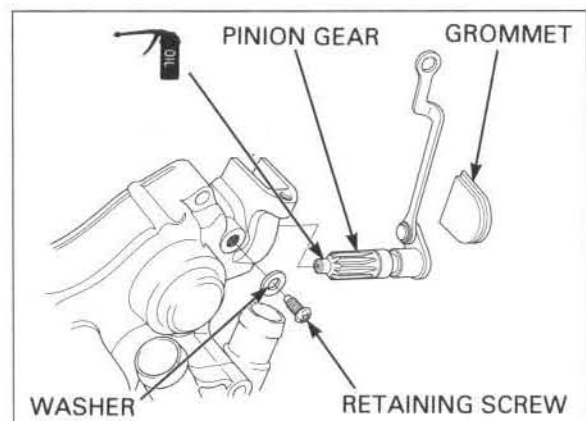

Apply molybdenum disulfide oil to the pinion rod joint and governor bearing rolling area.

Install the governor by positioning the pinion lever toward the top of the right crankcase cover. When the governor is installed, it will spin the pinion lever downward to its proper location.

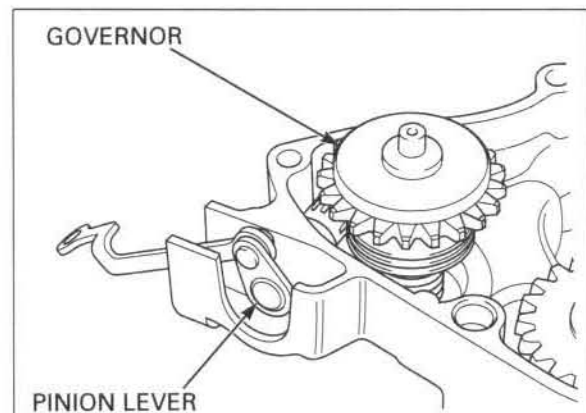

Make sure the pinion lever joint aligns with the index lines.

Install the washer and setting screw.

Tighten the screw to the specified torque.

TORQUE: 9 N·m (0.9 kgf·m, 6.5 lbf·ft)

Install the grommet with its tab facing outside as shown.

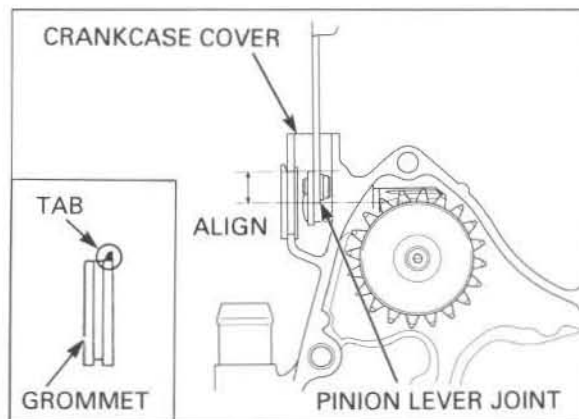

Install the following:

- Right crankcase cover (page 9-3)
- Pinion rod and RC valve cover (page 7-12)

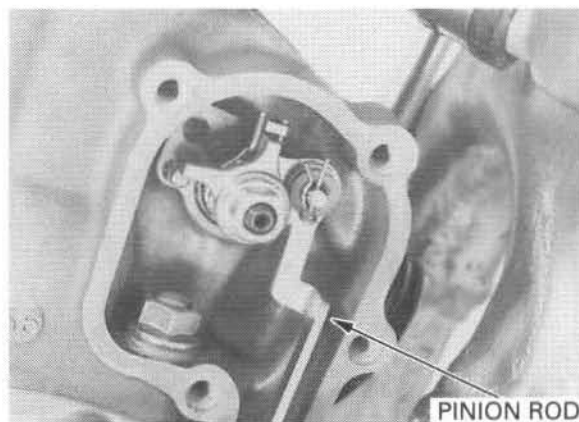

CLUTCH/KICKSTARTER/GEARSHIFT LINKAGE

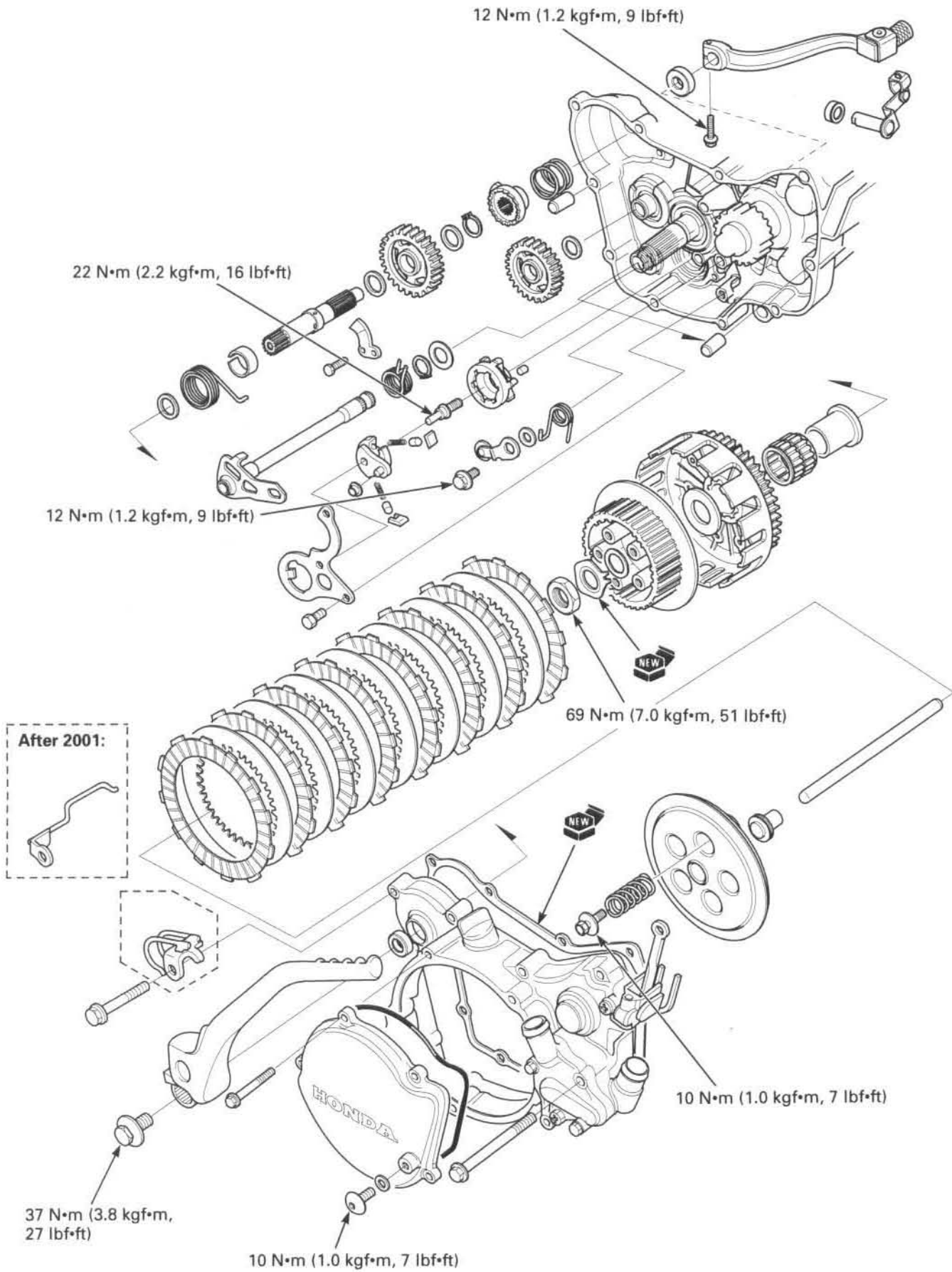

9. CLUTCH/KICKSTARTER/GEARSHIFT LINKAGE

SERVICE INFORMATION	9-1	CLUTCH	9-4
TROUBLESHOOTING	9-2	KICKSTARTER	9-12
RIGHT CRANKCASE COVER	9-3	GEARSHIFT LINKAGE	9-15

SERVICE INFORMATION

GENERAL

- This section covers service of the clutch, kickstarter and gearshift linkage. All service can be done with the engine installed in the frame.
- Transmission oil viscosity and level have an effect on clutch disengagement. Oil additives also affect clutch performance and are not recommended. When the clutch does not disengage or the motorcycle creeps with clutch disengaged, inspect the transmission oil level before servicing the clutch system.

SPECIFICATIONS

Unit: mm (in)

ITEM	STANDARD	SERVICE LIMIT
Clutch lever free play	10 – 20 (3/8 – 3/4)	—
Clutch spring free length	37.1 (1.46)	35.2 (1.39)
Clutch outer guide I.D.	20.000 – 20.021 (0.7874 – 0.7882)	20.05 (0.789)
Clutch disc thickness	2.92 – 3.08 (0.114 – 0.121)	2.85 (0.112)
Clutch plate warpage	—	0.15 (0.006)
Kickstarter pinion gear I.D.	16.516 – 16.534 (0.6502 – 0.6509)	16.55 (0.652)
Kickstarter spindle O.D.	16.466 – 16.484 (0.6483 – 0.6490)	16.45 (0.648)
Kickstarter idle gear I.D.	17.016 – 17.034 (0.6699 – 0.6706)	17.05 (0.671)
Countershaft O.D. at kickstarter idle gear	16.983 – 16.994 (0.6686 – 0.6691)	16.97 (0.668)

TORQUE VALUES

Gearshift drum center pin	22 N•m (2.2 kgf•m, 16 lbf•ft)	Apply a locking agent to the threads.
Gearshift drum stopper arm bolt	12 N•m (1.2 kgf•m, 9 lbf•ft)	
Clutch center lock nut	69 N•m (7.0 kgf•m, 51 lbf•ft)	
Right crankcase cover bolt	10 N•m (1.0 kgf•m, 7 lbf•ft)	
Clutch cover bolt	10 N•m (1.0 kgf•m, 7 lbf•ft)	
Clutch spring bolt	10 N•m (1.0 kgf•m, 7 lbf•ft)	
Gearshift pedal pinch bolt	12 N•m (1.2 kgf•m, 9 lbf•ft)	
Kickstarter pedal bolt	37 N•m (3.8 kgf•m, 27 lbf•ft)	

TOOL

Clutch center holder	07724 – 0050002 or Equivalent commercially available in U.S.A.
----------------------	--

TROUBLESHOOTING

Hard to shift

- Incorrect clutch adjustment
- Loose stopper plate bolt
- Damaged stopper plate and pin
- Damaged gearshift spindle

Transmission jumps out of gear

- Worn shift drum stopper arm
- Weak or broken shift arm return spring
- Loose stopper plate bolt

Gearshift pedal will not return

- Weak or broken gearshift spindle return spring
- Bent gearshift spindle

Clutch slips when accelerating

- Incorrect clutch adjustment
- Worn clutch discs
- Weak clutch springs
- Transmission oil mixed with molybdenum or graphite additive

Motorcycle creeps with the engine idling

- Incorrect clutch adjustment
- Clutch plate warped
- Faulty clutch lifter
- Incorrect transmission oil

RIGHT CRANKCASE COVER

REMOVAL

Drain the coolant (page 5-5).
 Drain the transmission oil (page 3-9).
 Remove the expansion chamber (page 2-7).
 Remove the brake pedal (page 13-20).
 Remove the RC valve cover and valve rod (page 7-5).

Remove the kickstarter pedal bolt and kickstarter pedal.

Remove the bolts and water pump cover (page 5-7).

Remove the bolts and right crankcase cover and hose clamp (After 2001:).

Remove the gasket and dowel pins.

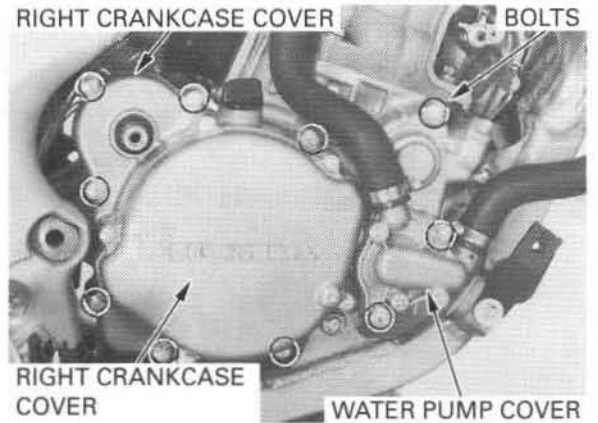
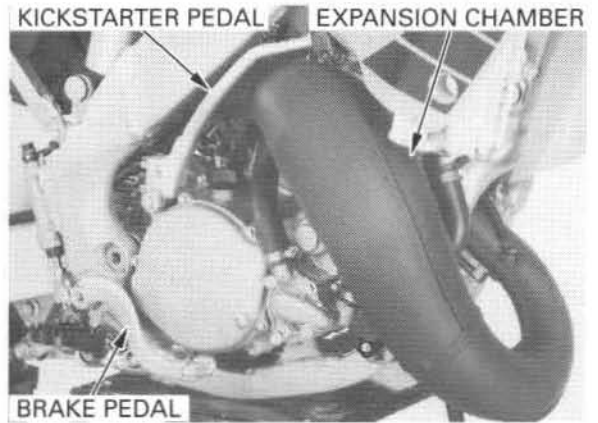

Check the starter spindle oil seal for deterioration or damage.

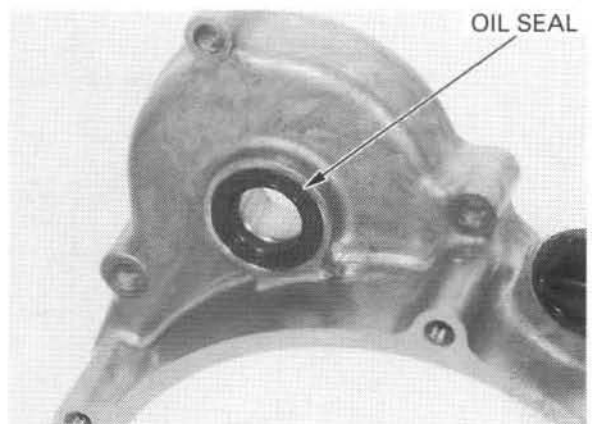

INSTALLATION

Place a new gasket on the right crankcase cover and cut the end of the gasket flush with the end as shown.

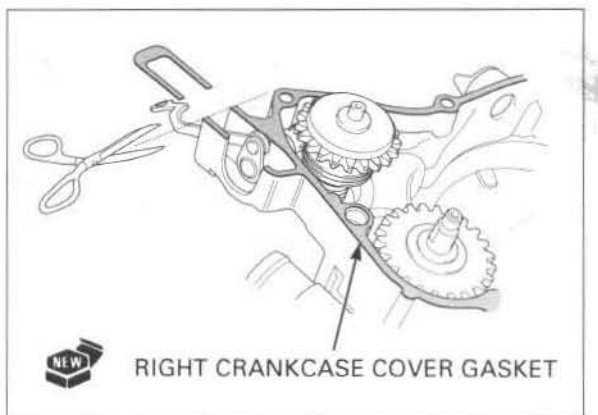

CLUTCH/KICKSTARTER/GEARSHIFT LINKAGE

Install the dowel pins and new gasket.

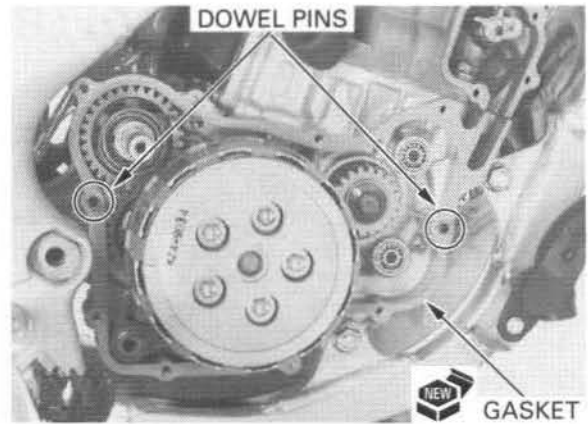

Install the right crankcase cover while engaging water pump gear with the primary drive gear.

Install and tighten the bolts with the hose clamp (After 2001:) to the specified torque.

TORQUE: 10 N•m (1.0 kgf•m, 7 lbf•ft)

Install the right crankcase cover.
Install the RC valve cover and valve rod (page 7-12).

Install the kickstarter pedal and bolt.
Tighten the kickstarter pedal bolt to the specified torque.

TORQUE: 38 N•m (3.9 kgf•m, 28 lbf•ft)

Install the brake pedal (page 13-21).
Install the expansion chamber (page 2-7).

Fill the transmission with the recommended oil to the correct level (page 3-9).
Pour the radiator coolant mixture into the radiator up to the correct level (page 5-4).
Check and adjust the rear brake pedal height (page 3-15).
Start the engine and check for oil leaks.

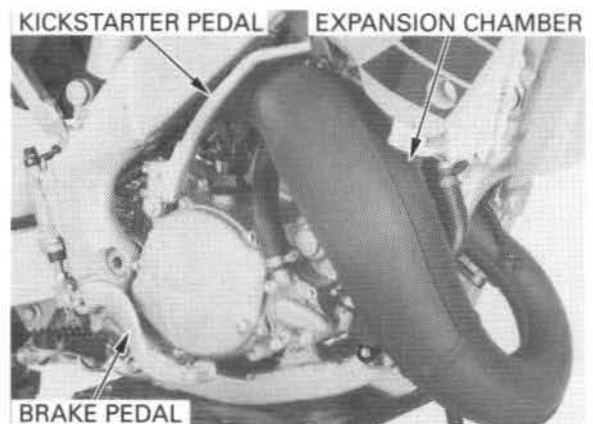
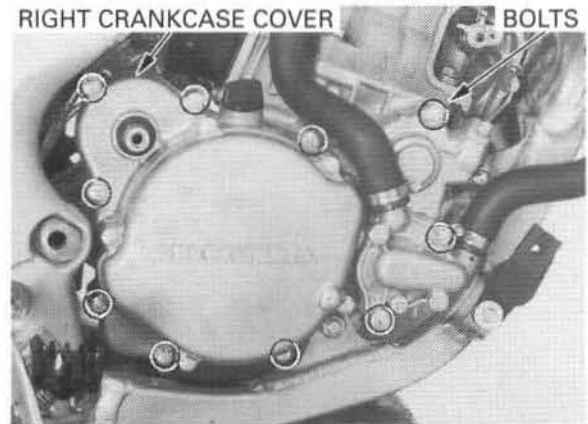

CLUTCH

CLUTCH REMOVAL

Remove the brake pedal (page 13-20).
Remove the bolts and clutch cover.

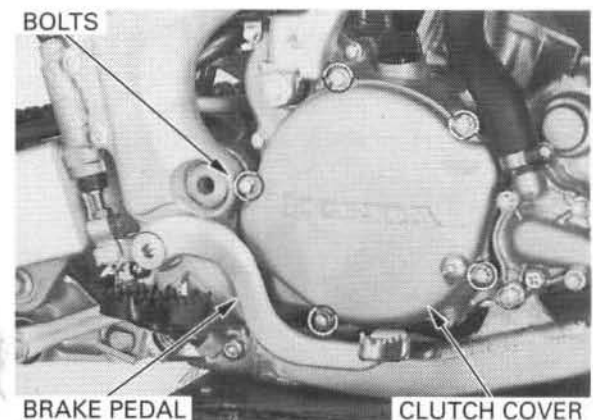

CLUTCH/KICKSTARTER/GEARSHIFT LINKAGE

Remove the five clutch spring bolts in a crisscross pattern in two or three steps.
Remove the clutch springs.

Remove the clutch pressure plate.

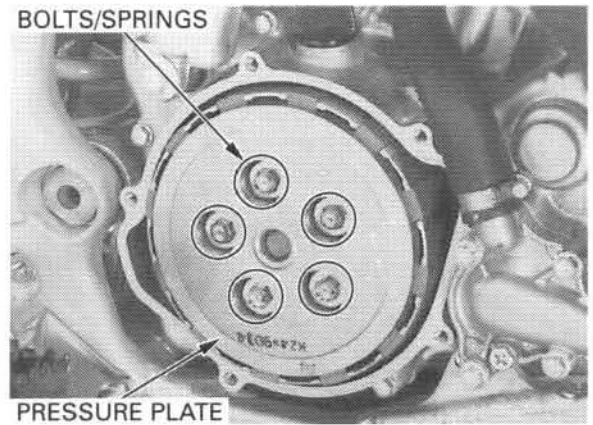

Remove the clutch lifter and lifter rod.

Remove the eight clutch friction discs and seven clutch plates.

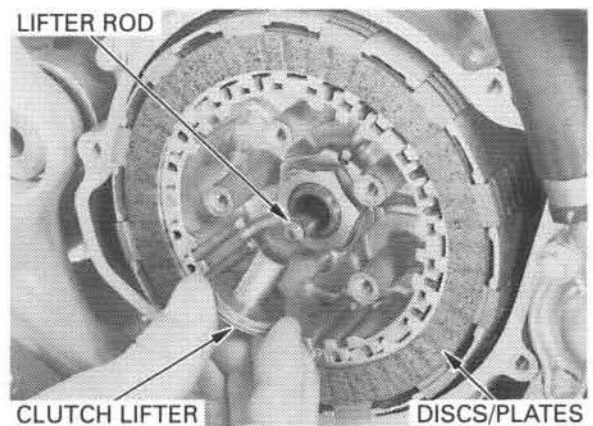

Bend the tabs of the lock washer away from the lock nut.

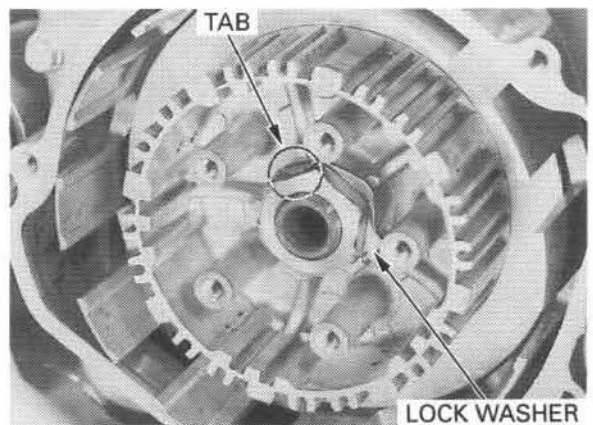

Hold the clutch center with the clutch center holder.
Remove the lock nut, lock washer and thrust washer.

TOOL:
Clutch center holder

07724 - 0050002 or
equivalent commercially
available in
U.S.A.

Remove the tool and clutch center.

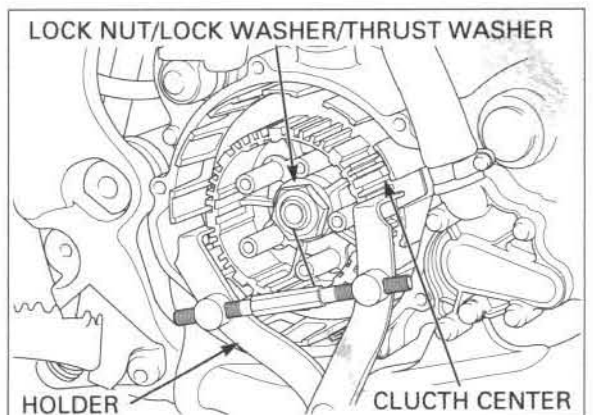

CLUTCH/KICKSTARTER/GEARSHIFT LINKAGE

Remove the thrust washer and clutch outer.

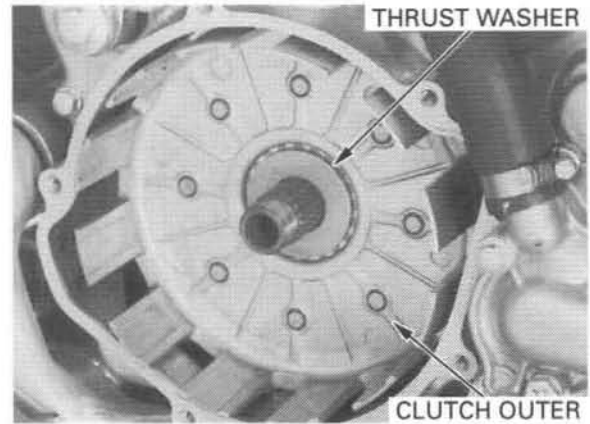

Remove the needle bearing and clutch outer guide.

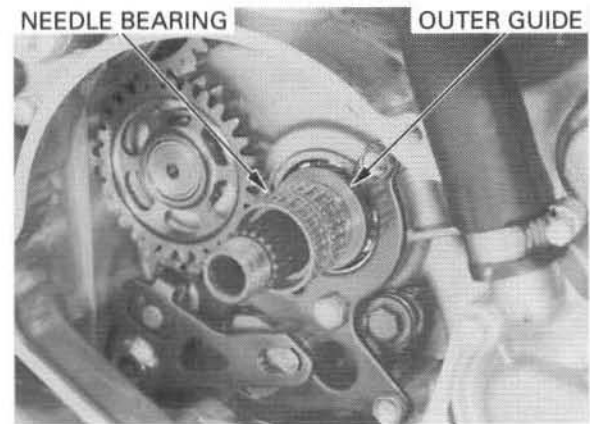

Remove the alternator cover (page 14-8).

Disconnect the clutch cable from the clutch lifter lever by loosening the clutch cable adjuster

Remove the flywheel and stator (page 14-8).

Remove the clutch lifter lever from the left crankcase.

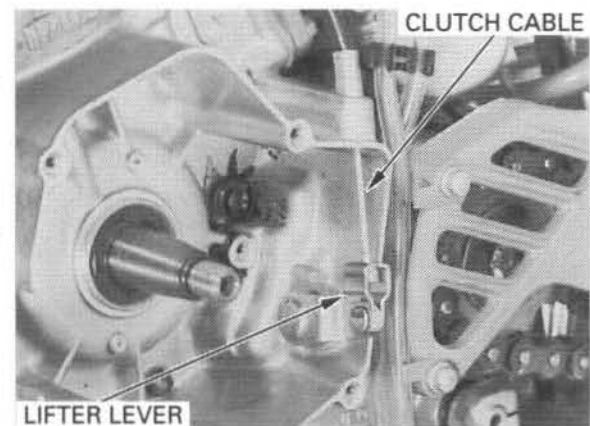

INSPECTION

CLUTCH SPRING

Replace the clutch springs as a set.

Measure the clutch spring free length.

SERVICE LIMIT: 35.2 mm (1.39 in)

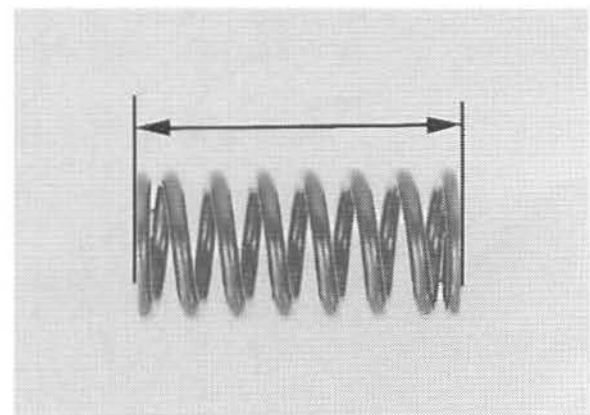

CLUTCH DISC

Check the clutch discs for signs of scoring or discoloration.

Replace the discs and plates as a set.

Measure the thickness of the discs.

SERVICE LIMIT: 2.85 mm (0.112 in)

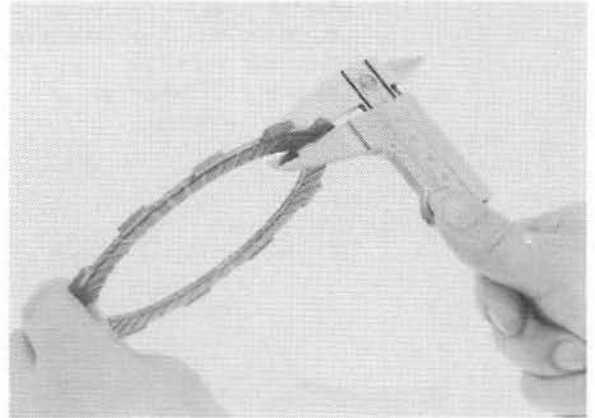

CLUTCH PLATE

Check the plate for excessive warpage or discoloration.

Replace the discs and plates as a set.

Check the plate warpage on a surface plate using a feeler gauge.

SERVICE LIMIT: 0.15 mm (0.006 in)

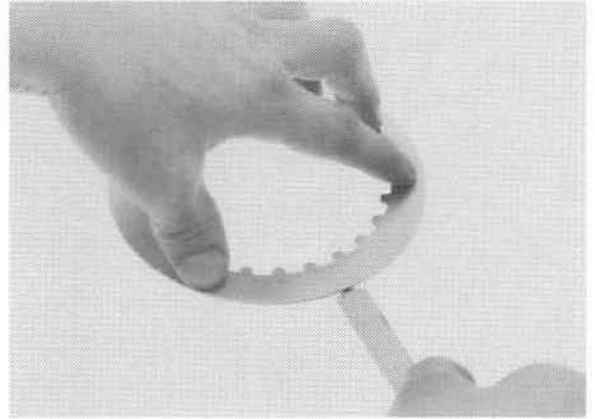

CLUTCH CENTER

Check the clutch center for nicks, indentations or abnormal wear made by the clutch plates.

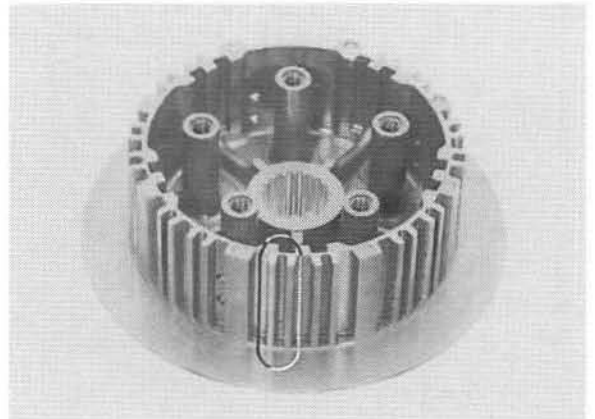

CLUTCH LIFTER

Check the clutch lifter for wear or damage.

CLUTCH LIFTER ROD

Check the clutch lifter rod for damage, and straightness.

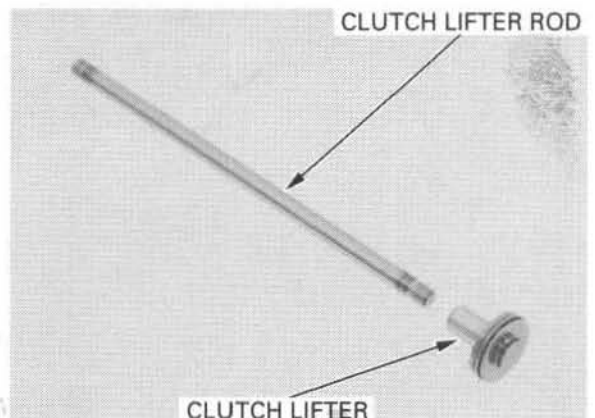

CLUTCH/KICKSTARTER/GEARSHIFT LINKAGE

CLUTCH OUTER

Check the clutch outer for nicks, indentations or abnormal wear made by the clutch discs.
Check the serrated teeth of the primary driven gear for wear or damage.

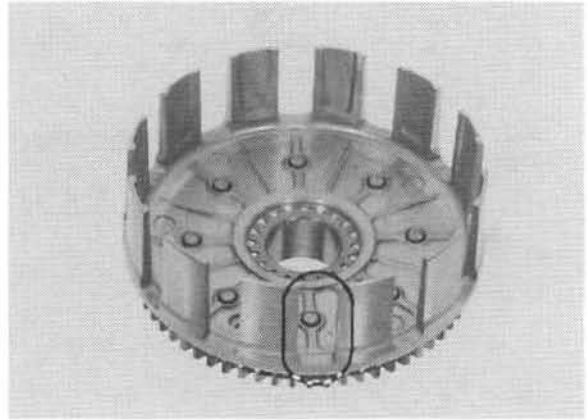

CLUTCH OUTER GUIDE

Check the clutch outer guide for abnormal wear or damage.

NEEDLE BEARING

Check the needle bearing for wear or damage.

Check the mainshaft for wear or damage at the sliding surface of the clutch outer guide.

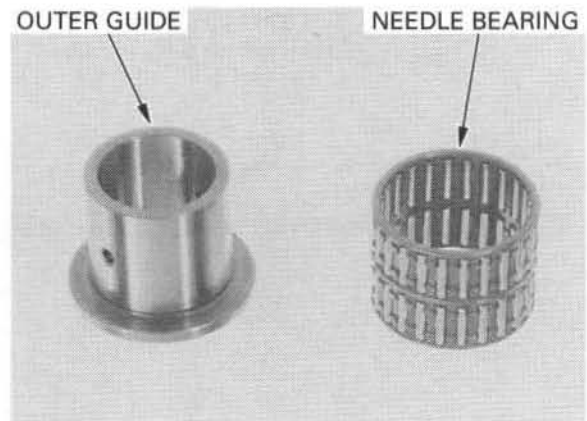

CLUTCH LIFTER LEVER

Check the clutch lifter lever for damage.

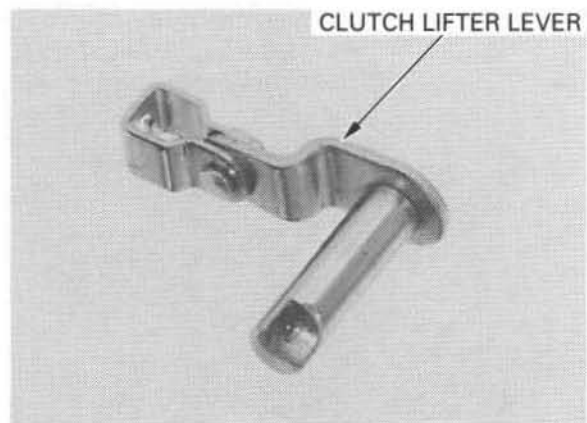

Check the oil seal and needle bearing for wear or damage.

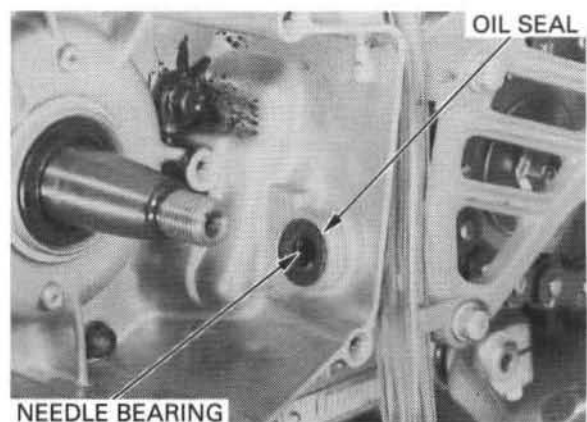

INSTALLATION

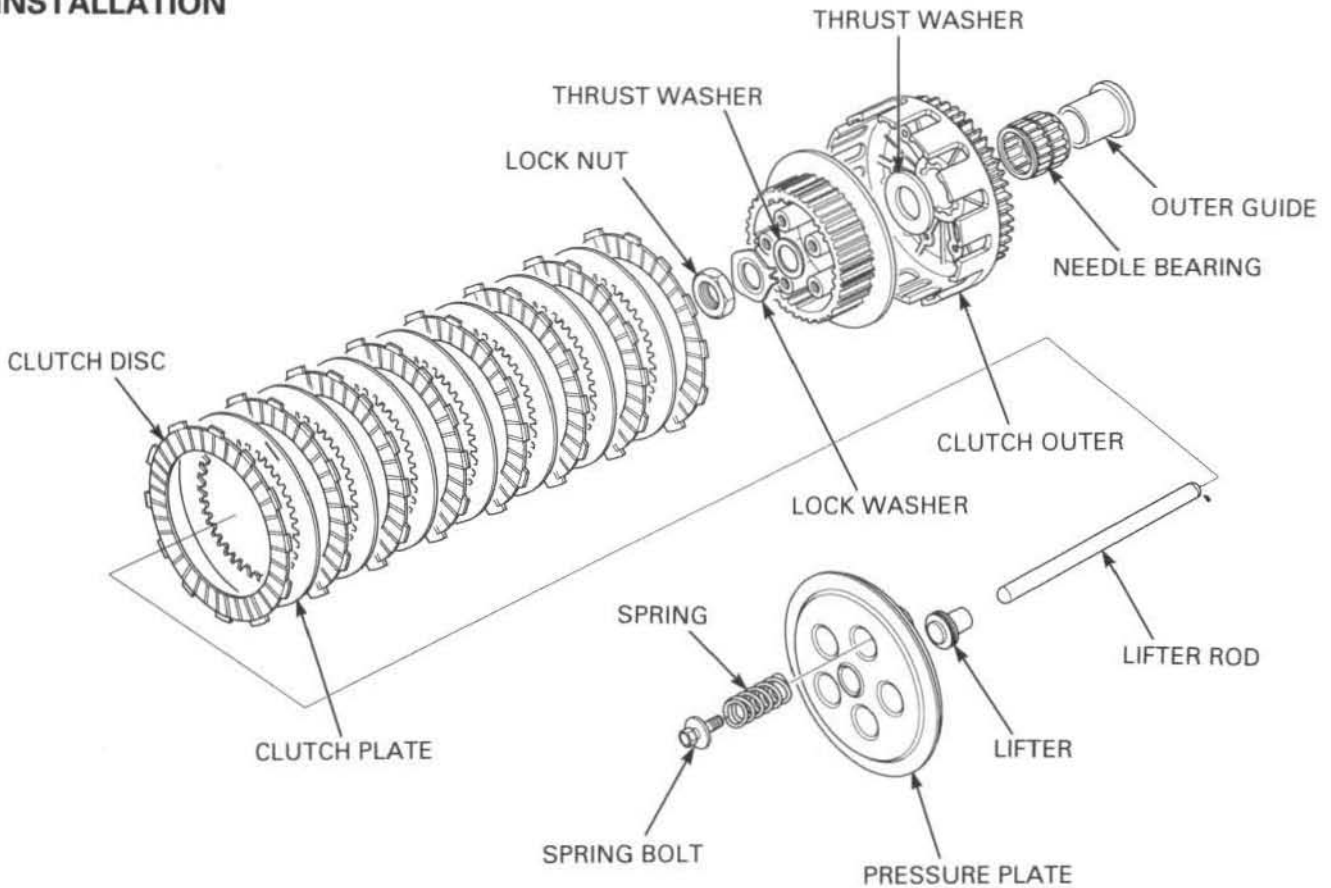

Apply Pro Honda Moly 60 or equivalent molybdenum paste to the clutch lifter lever sliding surface. Install the clutch lifter lever to the crankcase.

Install the stator and flywheel (page 14-9).

Connect the clutch cable to the clutch lifter lever.

After installation, check the following:

- Ignition timing (page 14-10)
- Clutch operation (page 3-15)

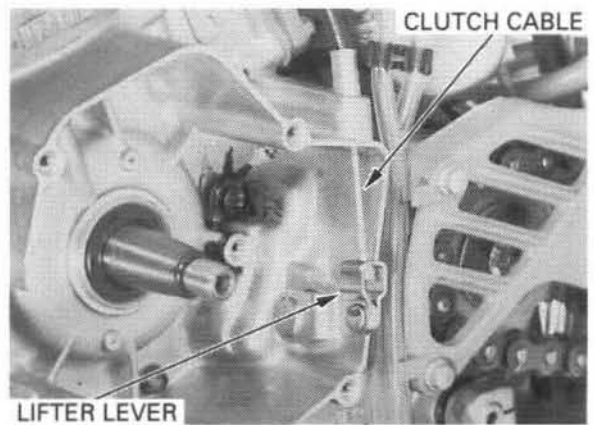

If removed, be sure to install the kickstarter and gearshift spindle before installing the clutch.

Apply transmission oil to the clutch outer guide and needle bearing.

Install the clutch outer guide and needle bearing onto the mainshaft.

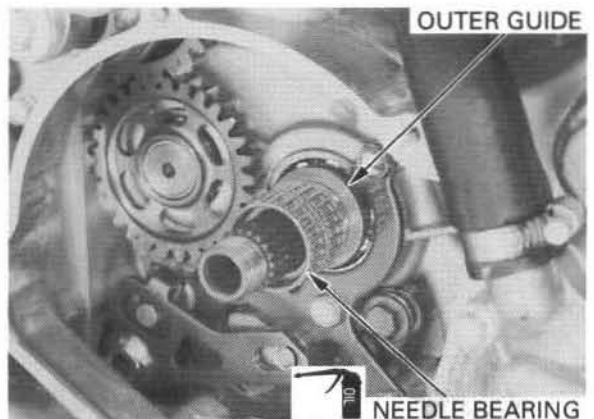

CLUTCH/KICKSTARTER/GEARSHIFT LINKAGE

Install the clutch outer and thrust washer.

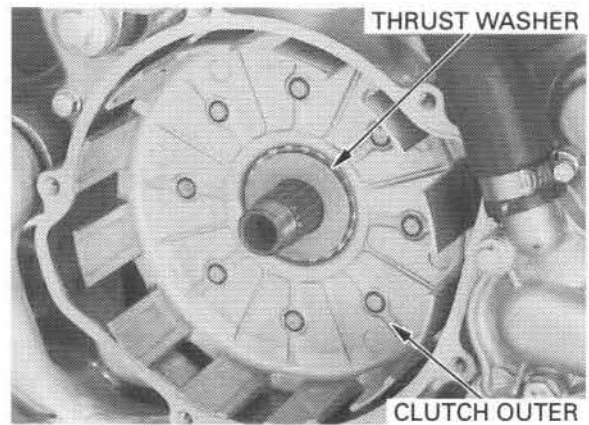

Install the clutch center onto the mainshaft.
Install the thrust washer.
Align the groove of the new lock washer with a rib on the clutch center and slip it into place on the mainshaft.

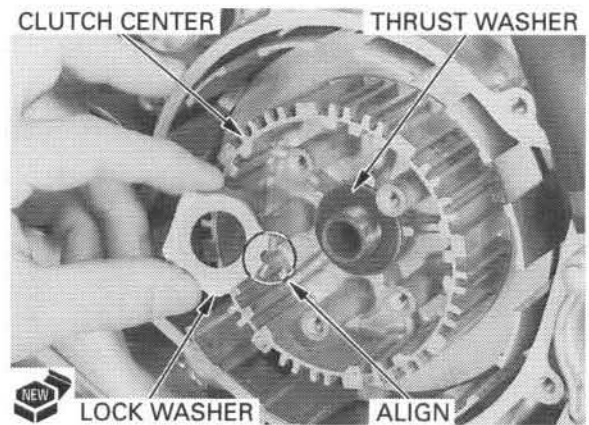

Install the clutch center lock nut and tighten the nut to the specified torque while holding the clutch center with the clutch center holder.

TOOL:

Clutch center holder

07724-0050002 or equivalent commercially available in U.S.A.

TORQUE: 69 N·m (7.0 kgf·m, 51 lbf·ft)

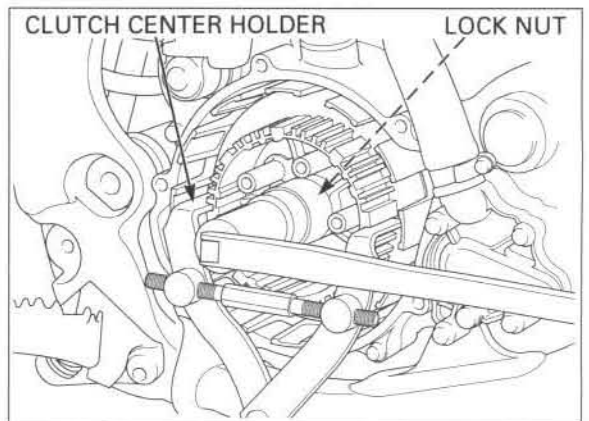

Bend the tabs of the lock washer up against the clutch center nut.

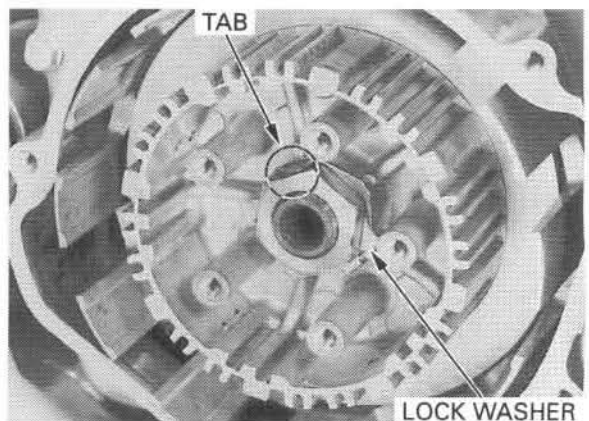

CLUTCH/KICKSTARTER/GEARSHIFT LINKAGE

Coat the clutch plates and discs with clean transmission oil.

Install the eight friction discs and seven clutch plates alternately, starting with a disc.

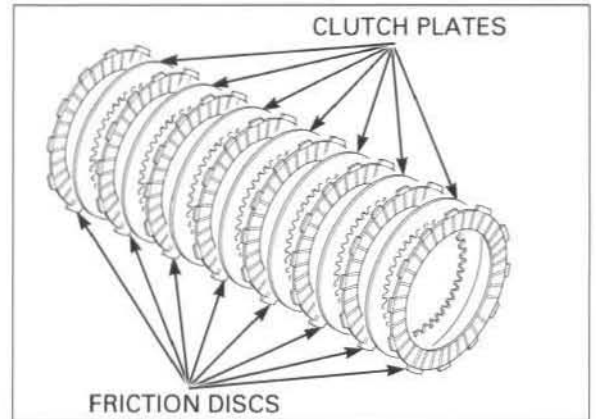

Apply grease to the clutch lifter rod.

Insert the clutch lifter rod into the mainshaft.
Install the clutch lifter.

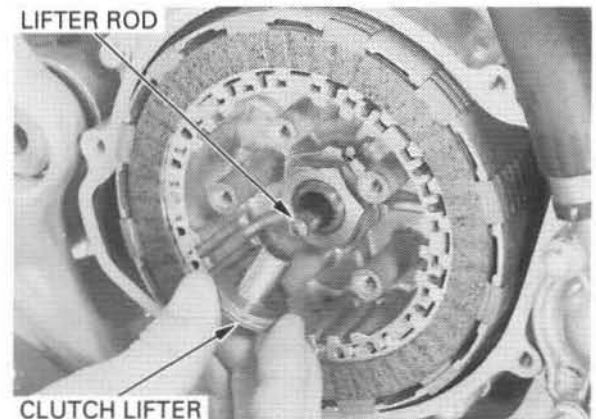

Install the clutch pressure plate.
Install the five springs and spring bolts.
Tighten the bolts in a crisscross pattern in two or three steps.

TORQUE: 10 N·m (1.0 kgf·m, 7 lbf·ft)

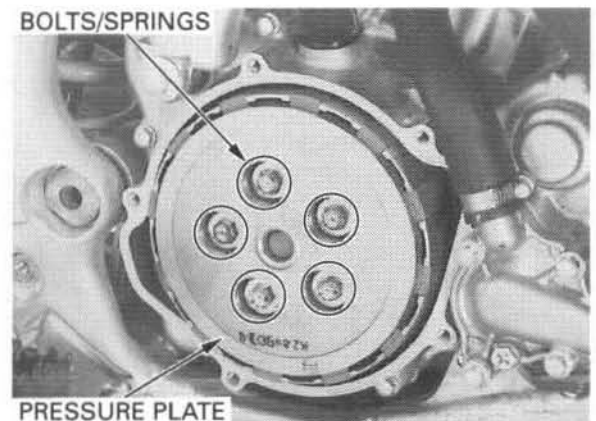

Check that the clutch cover O-ring is in good condition.
Apply oil to the O-ring and install the clutch cover.

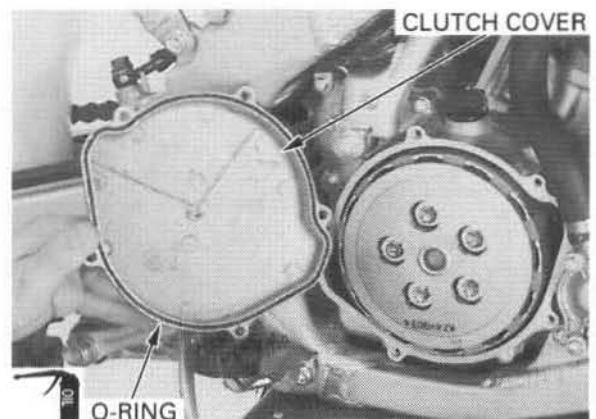

CLUTCH/KICKSTARTER/GEARSHIFT LINKAGE

Install and tighten the clutch cover bolts to the specified torque.

TORQUE: 10 N·m (1.0 kgf·m, 7 lbf·ft)

Install the brake pedal (page 13-21).
Adjust the clutch lever free play (page 3-15).

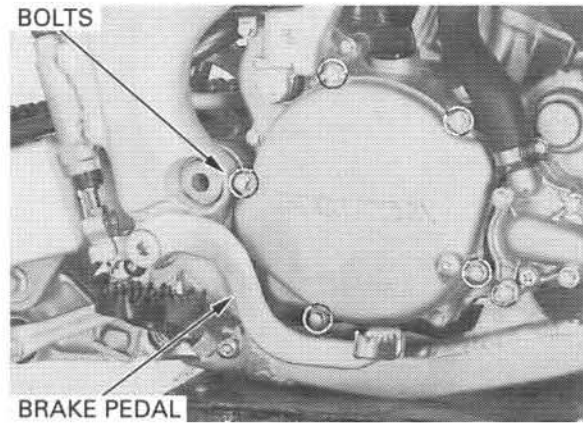

KICKSTARTER

REMOVAL

Remove the right crankcase cover (page 9-3).
Remove the clutch (page 9-4).

Remove the idle gear and washer.

Unhook the kickstarter return spring from the crankcase, and pull the kickstarter spindle assembly out.

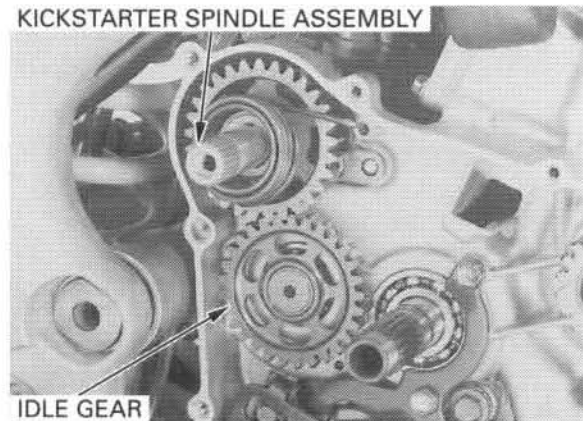

DISASSEMBLY

Disassemble the kickstarter spindle by removing the following:

- Thrust washer and collar
- Return spring
- Ratchet spring and starter ratchet
- Snap ring, thrust washers and pinion gear

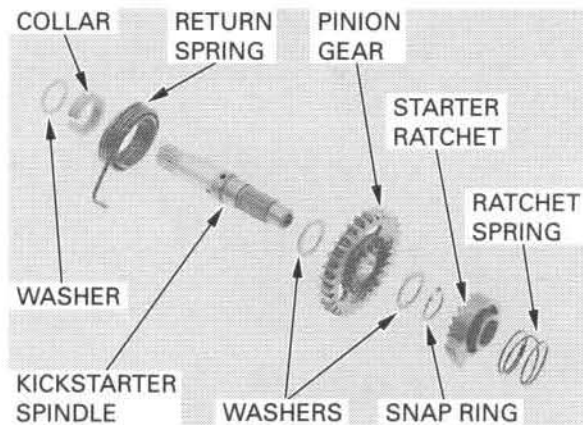

INSPECTION

Check the return spring and ratchet spring for weakness or damage.
Check the starter ratchet for wear or damage.

Measure the kickstarter pinion gear I.D.

SERVICE LIMIT: 16.55 mm (0.652 in)

Measure the kickstarter spindle O.D.

SERVICE LIMIT: 16.45 mm (0.648 in)

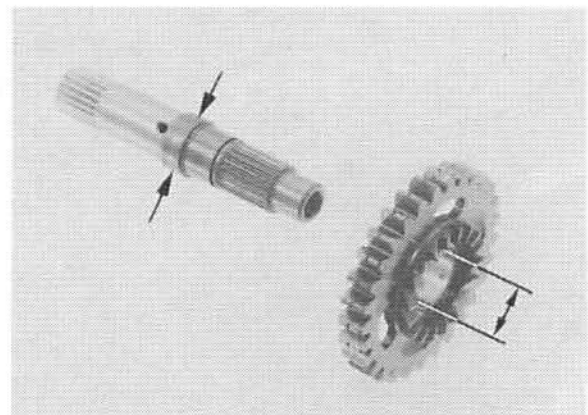

Check the starter idle gear and bushing for wear or damage.

Measure the kickstarter idle gear I.D.

SERVICE LIMIT: 17.05 mm (0.671 in)

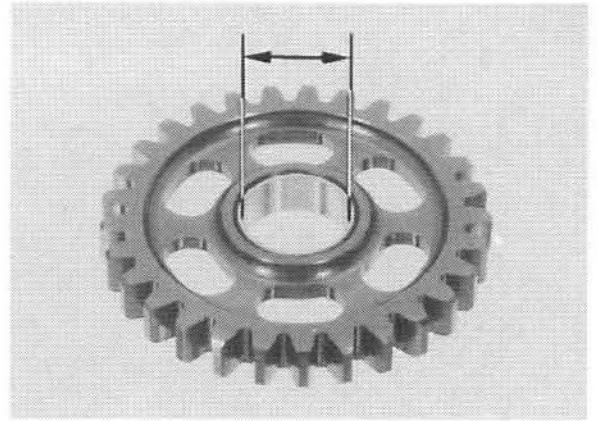

Measure the countershaft O.D. at idle gear bushing sliding surface.

SERVICE LIMIT: 16.97 mm (0.668 in)

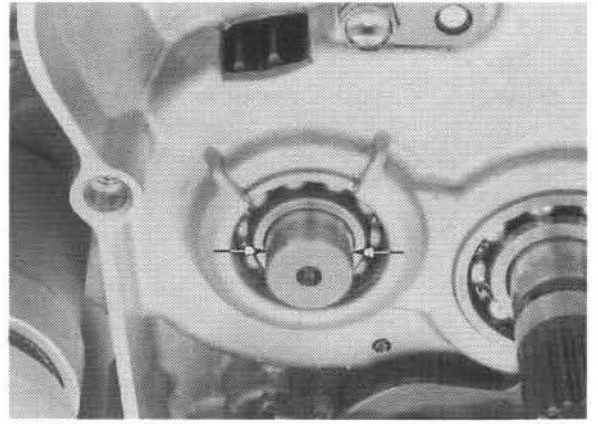

ASSEMBLY

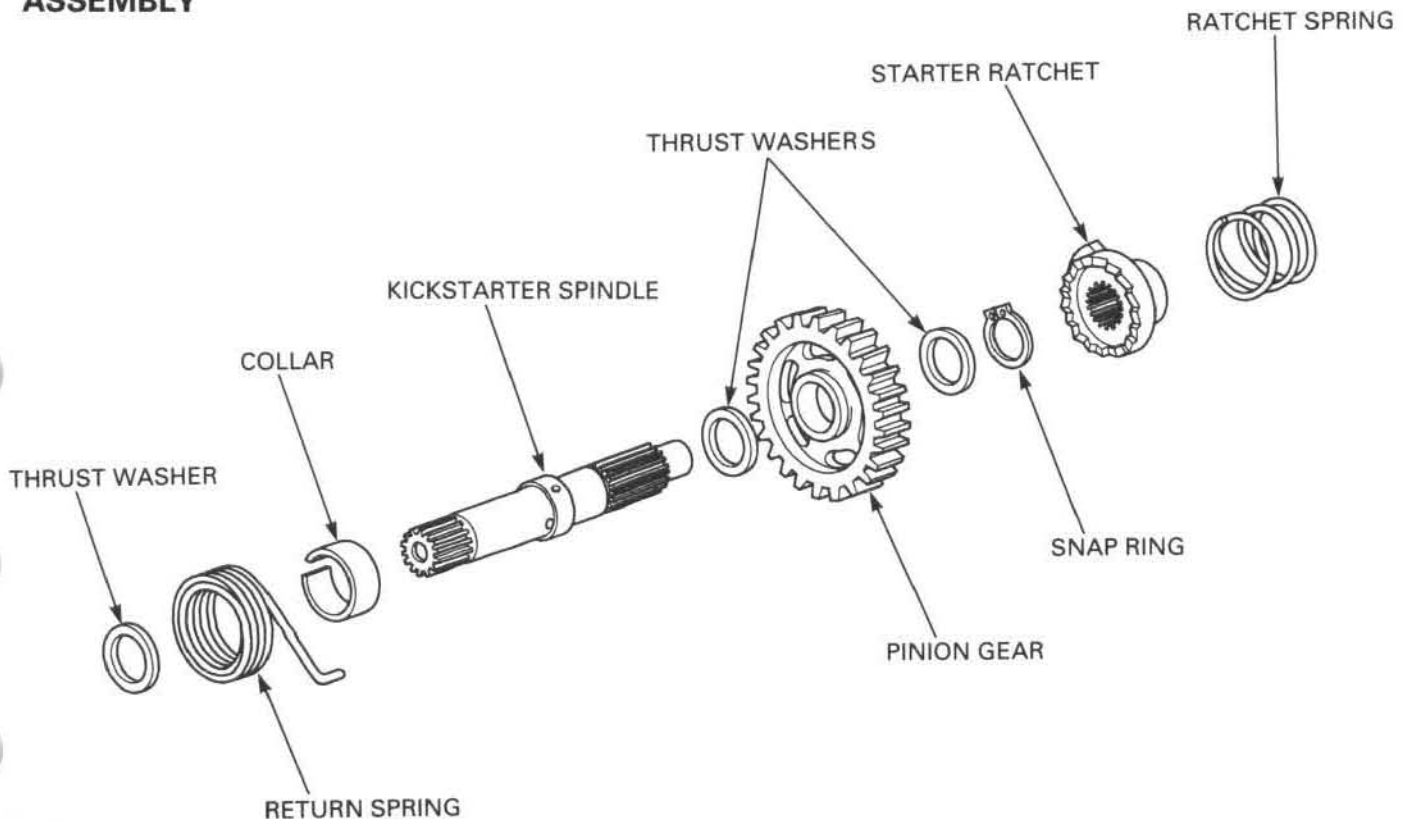

CLUTCH/KICKSTARTER/GEARSHIFT LINKAGE

Insert the return spring into the spring hook on the starter spindle shoulder.

Install the collar by aligning the cut-out of the collar with the spring, then install the thrust washer.

RETURN SPRING

COLLAR

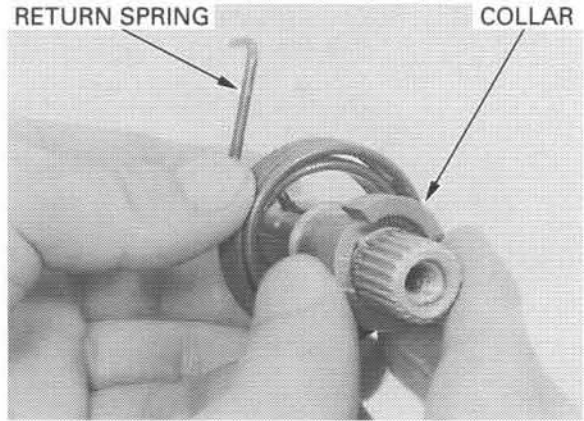

Apply molybdenum disulfide oil to the kickstarter spindle.

Install the thrust washer and pinion gear.

Install the thrust washer.

Set the sharp edge of the snap ring facing towards the outside.

SNAP RING

THRUST WASHER

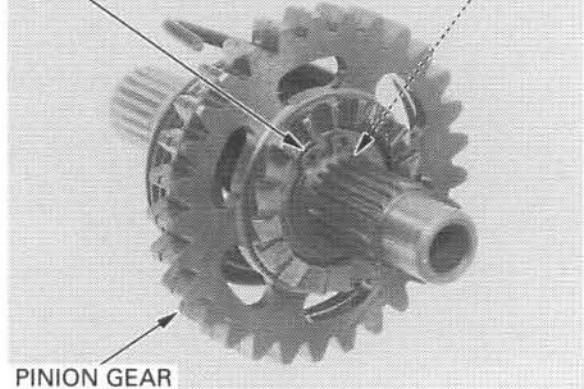

PINION GEAR

Aligning the punch marks and install the starter ratchet.

PUNCH MARKS

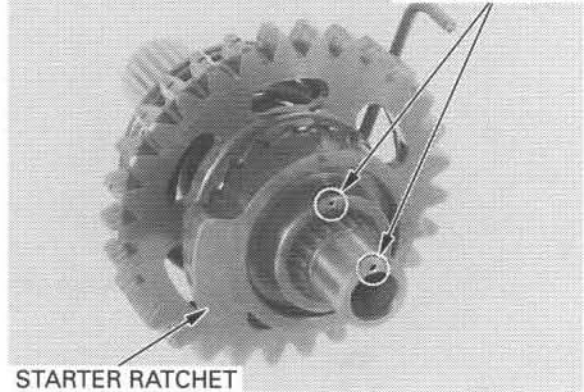

STARTER RATCHET

Install the ratchet spring.

RATCHET SPRING

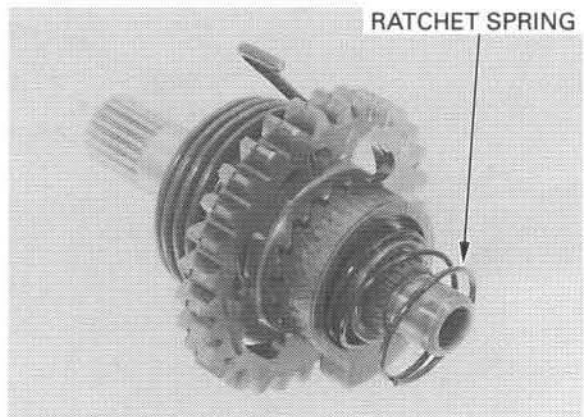

Install the thrust washer to the countershaft.
Install the starter idle gear and washer to the countershaft.

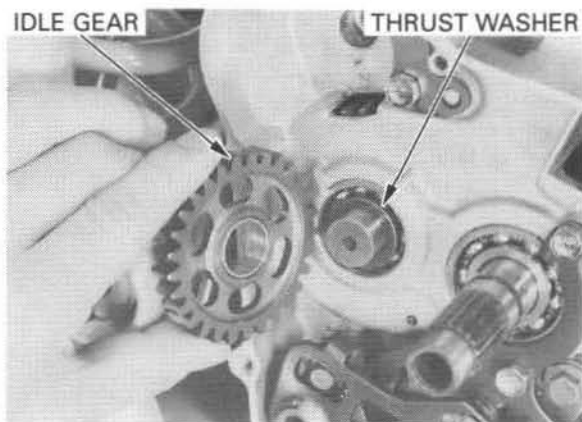

Be sure to preload the kickstarter return spring before installing the hook into the crankcase.

Install the kickstarter spindle and hook the return spring end to the crankcase.

Install the following:

- Clutch (page 9-9)
- Right crankcase cover (page 9-3)

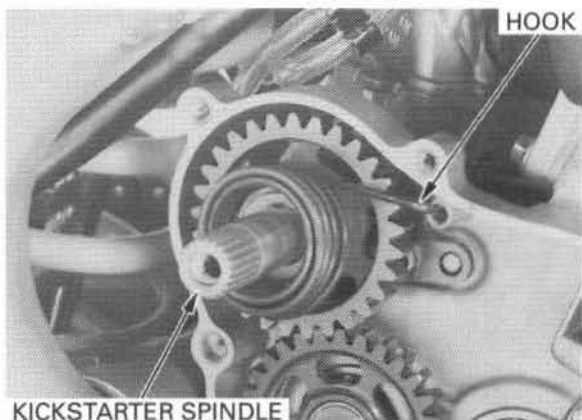

GEARSHIFT LINKAGE

REMOVAL

Remove the right crankcase cover (page 9-3).
Remove the clutch (page 9-4).

Remove the bolt and gearshift pedal.

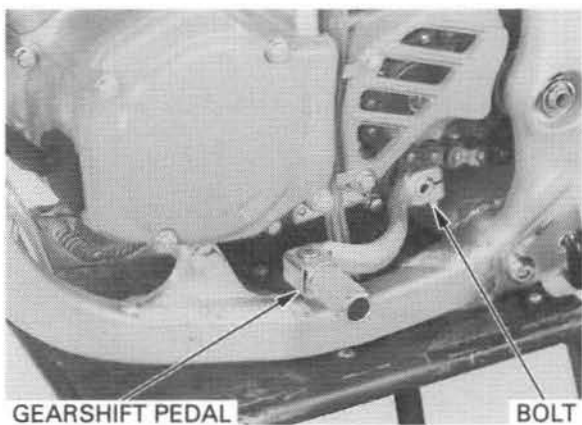

Remove the gearshift spindle and washer from the crankcase.

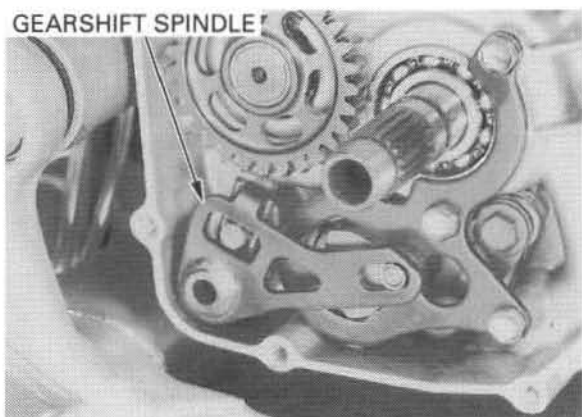

CLUTCH/KICKSTARTER/GEARSHIFT LINKAGE

Remove the shifter collar.
Remove the bolts.
Remove the guide plate and drum shifter as an assembly.

Do not let the ratchet pawls fall when removing the guide plate and drum shifter.

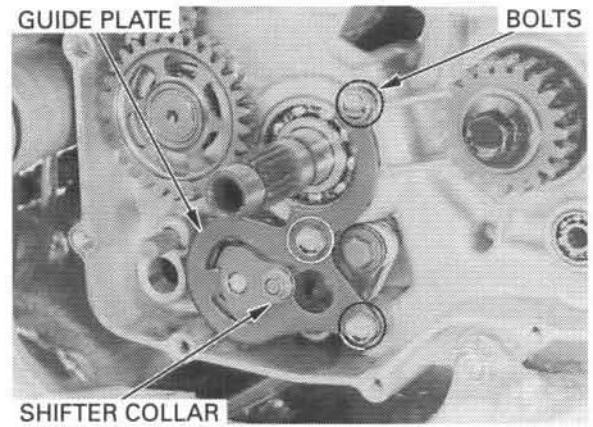

Remove the shift drum center pin and shift drum center.

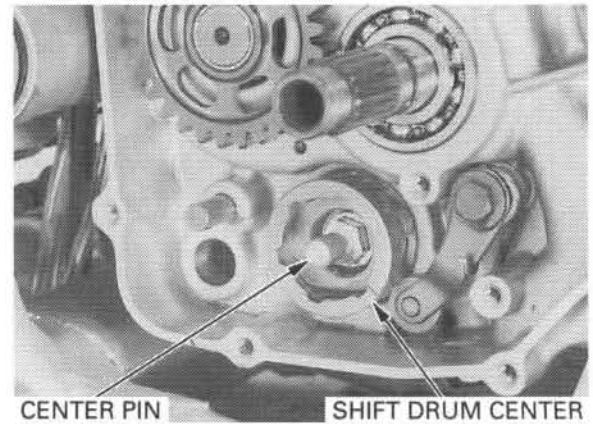

Remove the bolt, stopper arm, return spring and washer.

Remove the drum pin from the shift drum.

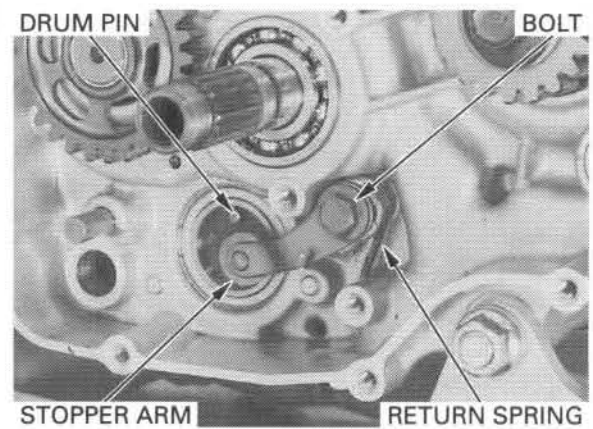

INSPECTION

GEARSHIFT SPINDLE

Check the gearshift spindle for wear or damage.
Check the return spring for fatigue or damage.

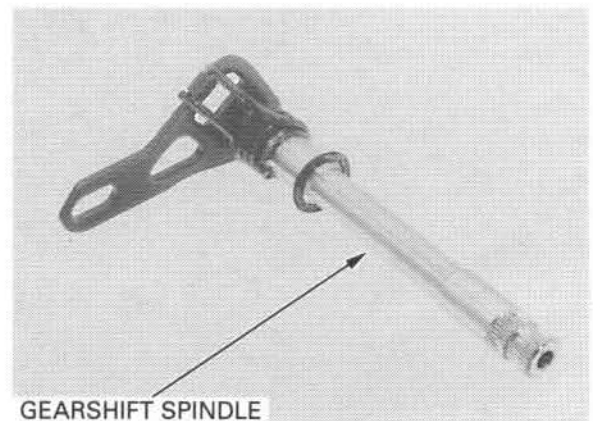

RATCHET PAWL

Clean the ratchet pawls, plungers, springs and drum shifter with clean transmission oil.

Check the parts for wear or damage.

Apply clean transmission oil to the each part. Assemble the drum shifter, springs, plungers and ratchet pawls in the guide plate as shown.

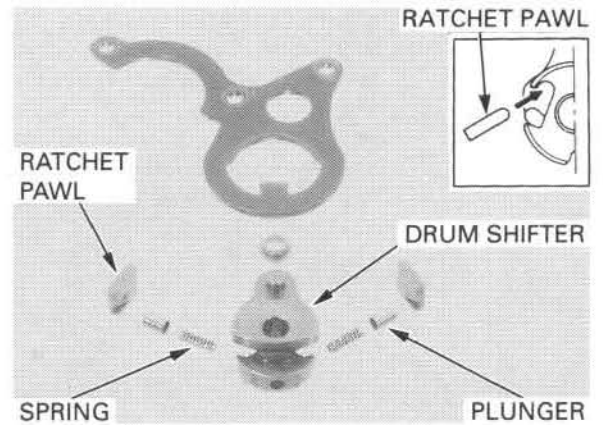

INSTALLATION

Install the drum pin to the hole on the shift drum.

Install the return spring, washer and stopper arm and tighten the stopper arm bolt to the specified torque.

TORQUE: 12 N·m (1.2 kgf·m, 9 lbf·ft)

Check the stopper arm for proper operation.

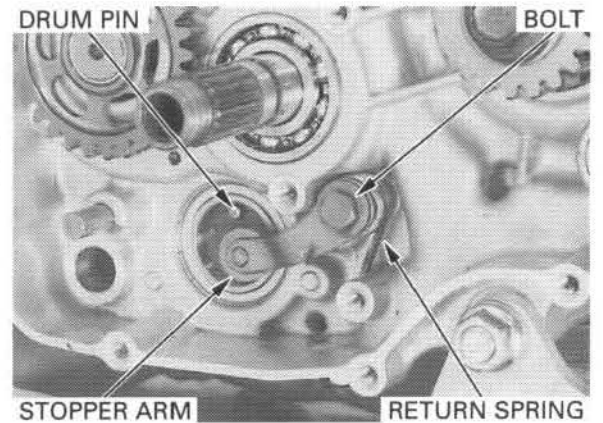

Move the stopper arm out of the way using a screwdriver. Align the shift drum center hole with the dowel pin and slip it into place.

Clean and apply a locking agent to the gearshift drum center pin threads.

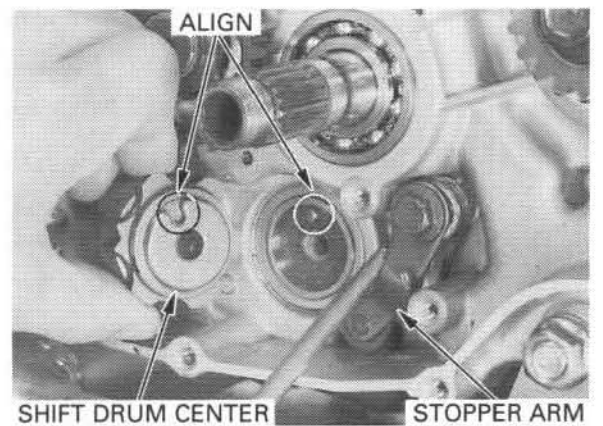

Install and tighten the shift drum center pin to the specified torque.

TORQUE: 22 N·m (2.2 kgf·m, 16 lbf·ft)

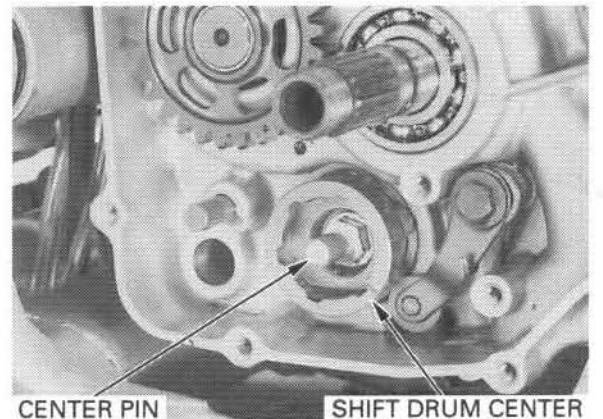

CLUTCH/KICKSTARTER/GEARSHIFT LINKAGE

Position the drum center in a gear other than neutral. Holding the ratchet pawls in place in the guide plate, and drum shifter, install the assembly onto the shift drum center pin.

Install and tighten the guide plate bolts securely. Install the shifter collar onto the drum shifter.

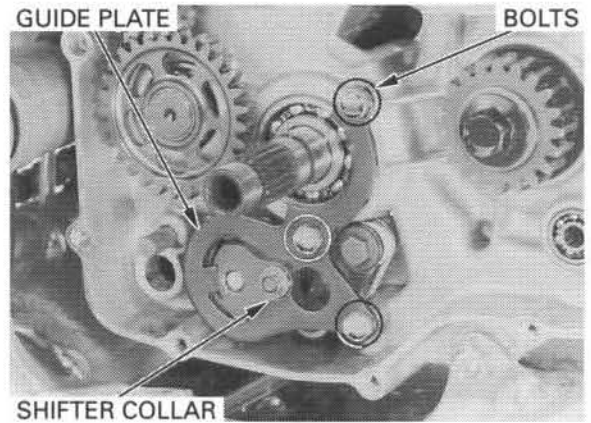

Do not forget to install the washer onto the gearshift spindle

Assemble and install the washer to the gearshift spindle.

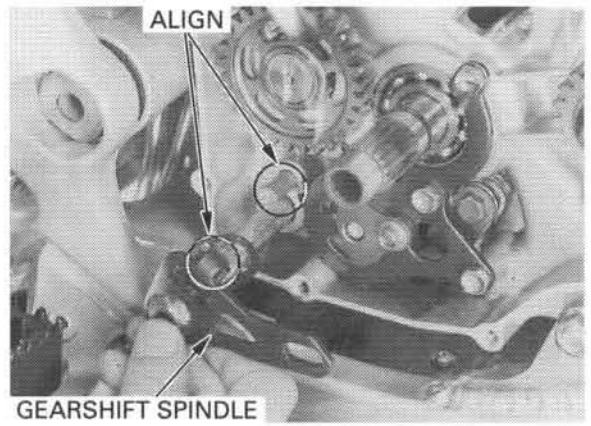

Install the gearshift pedal and bolt. Tighten the bolt to the specified torque.

TORQUE: 12 N·m (1.2 kgf·m, 9 lbf·ft)

Move the gearshift pedal and check the shift mechanism for smooth operation.

Install the clutch (page 9-9).
Install the right crankcase cover (page 9-3).

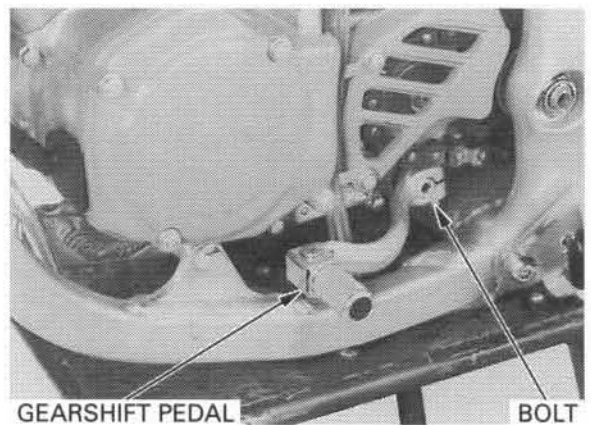

MEMO

CRANKCASE/CRANKSHAFT/TRANSMISSION

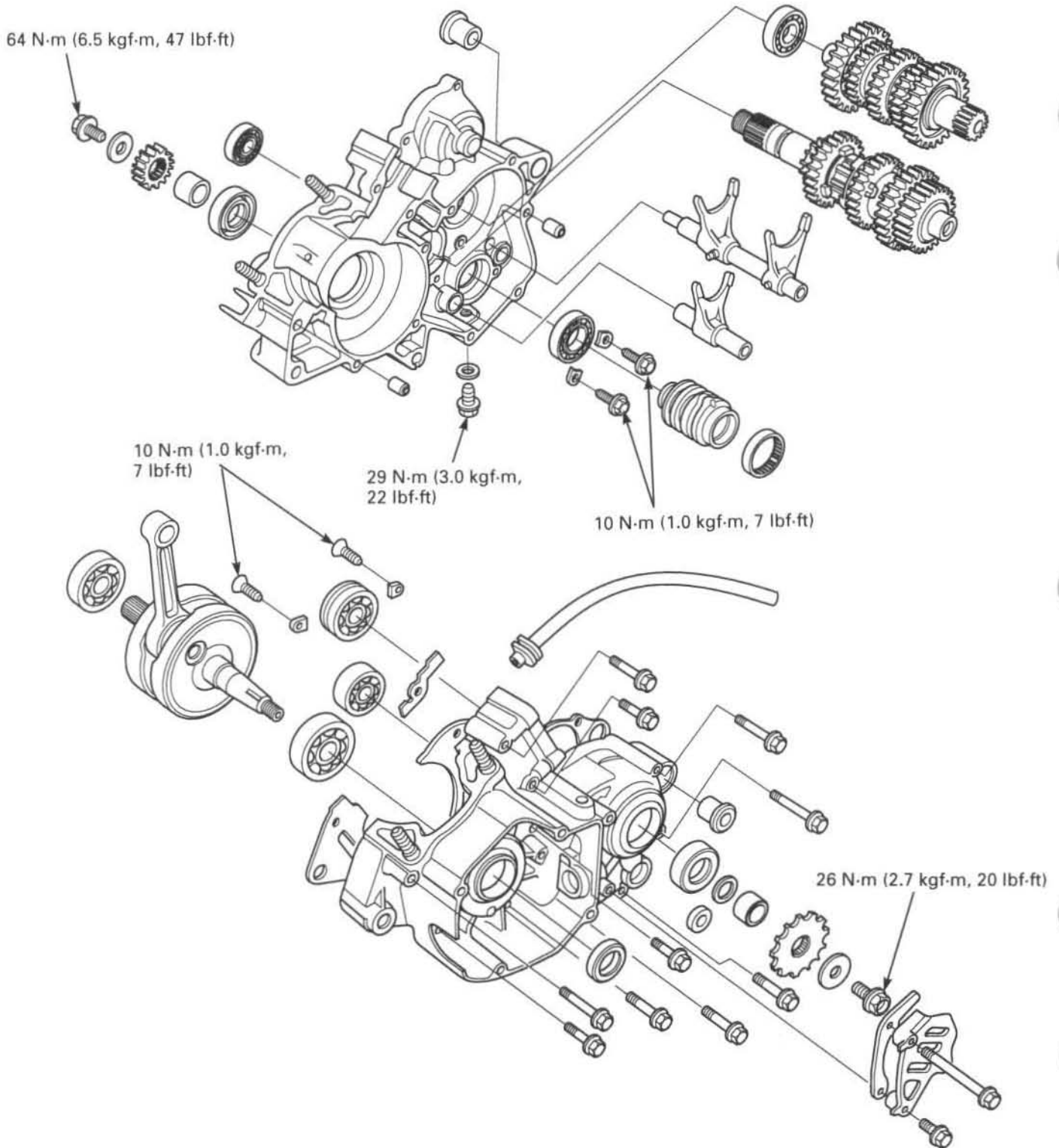

10. CRANKCASE/CRANKSHAFT/TRANSMISSION

SERVICE INFORMATION	10-1	CRANKCASE BEARING REPLACEMENT	10-9
TROUBLESHOOTING	10-3	CRANKSHAFT INSTALLATION	10-13
CRANKCASE SEPARATION	10-4	TRANSMISSION ASSEMBLY	10-14
TRANSMISSION DISASSEMBLY	10-6	CRANKCASE ASSEMBLY	10-16
CRANKSHAFT REMOVAL	10-8		

SERVICE INFORMATION

GENERAL

- This section covers crankcase separation for service of the crankshaft, transmission and kickstarter.
- The crankcase must be separated to service the crankshaft and transmission.
- The engine must be out of the frame for this service.
- The following parts must be removed before separating the crankcase.
 - Alternator (section 14)
 - Clutch/kickstarter/gearshift linkage (section 9)
 - Cylinder head/cylinder/piston (section 7)
 - Engine (section 6)

CRANKCASE/CRANKSHAFT/TRANSMISSION

SPECIFICATIONS

Unit: mm (in)

ITEM		STANDARD	SERVICE LIMIT	
Crankshaft	Side clearance	0.4 – 0.8 (0.02 – 0.03)	0.9 (0.04)	
	Radial clearance	0.010 – 0.022 (0.0004 – 0.0009)	0.032 (0.0013)	
	Runout	—	0.05 (0.002)	
Transmission	Gear I.D.	M4, M5	23.020 – 23.041 (0.9063 – 0.9071)	23.06 (0.908)
		C1	20.020 – 20.041 (0.7882 – 0.7890)	20.06 (0.790)
		C2, C3	25.020 – 25.041 (0.9850 – 0.9859)	25.06 (0.987)
	Bushing O.D.	M4, M5	22.979 – 23.000 (0.9047 – 0.9055)	22.95 (0.904)
		C1	19.979 – 20.000 (0.7866 – 0.7874)	19.95 (0.785)
		C2, C3	24.979 – 25.000 (0.9834 – 0.9843)	24.95 (0.982)
	Bushing I.D.	M5	20.000 – 20.021 (0.7874 – 0.7782)	20.04 (0.789)
		C1	17.000 – 17.018 (0.6693 – 0.6700)	17.03 (0.670)
		C2, C3	22.000 – 22.021 (0.8661 – 0.8670)	22.04 (0.868)
	Gear-to-bushing clearance	M4, C1, C2, C3	0.020 – 0.062 (0.0008 – 0.0024)	0.11 (0.004)
		M5	0.040 – 0.082 (0.0016 – 0.0032)	0.12 (0.005)
	Mainshaft O.D.	M5	19.959 – 19.980 (0.7858 – 0.7866)	19.94 (0.785)
	Countershaft O.D.	C1 bushing	16.983 – 16.994 (0.6686 – 0.6691)	16.97 (0.668)
		C2 bushing, C3 bushing	21.959 – 21.980 (0.8645 – 0.8654)	21.94 (0.864)
		Starter idle gear	16.983 – 16.994 (0.6686 – 0.6691)	16.97 (0.668)
Bushing-to-shaft clearance	M5, C2, C3	0.020 – 0.062 (0.0008 – 0.0024)	0.10 (0.004)	
	C1	0.006 – 0.035 (0.0002 – 0.0014)	0.06 (0.002)	
Shift fork, shaft	Fork claw thickness	4.93 – 5.00 (0.194 – 0.197)	4.8 (0.19)	
	Shift fork I.D.	11.035 – 11.056 (0.4344 – 0.4353)	11.065 (0.4356)	
	Fork shaft O.D.	10.983 – 10.994 (0.4324 – 0.4328)	10.973 (0.4320)	

TORQUE VALUES

Primary drive gear bolt	64 N•m (6.5 kgf•m, 47 lbf•ft)	
Countershaft bearing set plate bolt	10 N•m (1.0 kgf•m, 7 lbf•ft)	Apply a locking agent to the threads.
Gearshift drum bearing set plate screw	10 N•m (1.0 kgf•m, 7 lbf•ft)	Apply a locking agent to the threads.
Drive sprocket bolt	26 N•m (2.7 kgf•m, 20 lbf•ft)	

TOOLS

Universal bearing puller	07631 – 0010000	
Gear holder	07724 – 0010200	Not available in U. S. A.
Universal holder	07725 – 0030000	
Attachment, 37 x 40 mm	07746 – 0010200	
Attachment, 42 x 47 mm	07746 – 0010300	
Attachment, 52 x 55 mm	07746 – 0010400	
Pilot, 17 mm	07746 – 0040400	
Pilot, 20 mm	07746 – 0040500	
Pilot, 25 mm	07746 – 0040600	
Pilot, 28 mm	07746 – 0041100	
Driver	07749 – 0010000	
Bearing remover, 17 mm	07936 – 3710300	
– Remover weight	07741 – 0010201	or 07936 – 371020A or 07936 – 3710200
– Remover handle	07936 – 3710100	
Crankcase puller	07937 – 4300001	or 07937 – 4300000 or 07631 – 0010000 use with 6 x 100 mm bolts and large washers
Crankcase assembly tool set	07965 – 1660102	Not available in U.S.A. or 07965 – 1660101 or 07965 – 1660100
– Assembly tool shaft	07965 – 1660200	
– Assembly collar	07965 – 1660302	or 07965 – 1660301 or 07965 – 1660302 or 07965 – 166030A (Not available in U.S.A.) or 07VMF – HM8010A
Threaded adapter	07965 – KA30000	
Assembly collar	07965 – VM00100	
Threaded shaft	07995 – VM00200	or 07931 – ME4010B and 07931 – HB3020A (U.S.A. only)

TROUBLESHOOTING

Excessive noise

- Worn crankpin bearing
- Worn transmission bearing (s)
- Worn crankshaft bearing

Transmission jumps out of gear

- Worn gear dogs and slots
- Bent fork shaft
- Broken shift drum stopper
- Worn or bent shift forks
- Broken shift linkage return spring

Hard to shift

- Improper clutch operation
- Incorrect transmission oil weight
- Incorrect clutch adjustment
- Bent shift fork
- Bent fork shaft
- Bent fork claw
- Damaged shift drum cam grooves
- Bent shift spindle

Engine vibration

- Excessive crankshaft runout

CRANKCASE SEPARATION

NOTE:

Refer to service information (page 10-1) for removal of necessary parts before separating the crankcase.

Remove the drive sprocket guard by removing the two bolts.

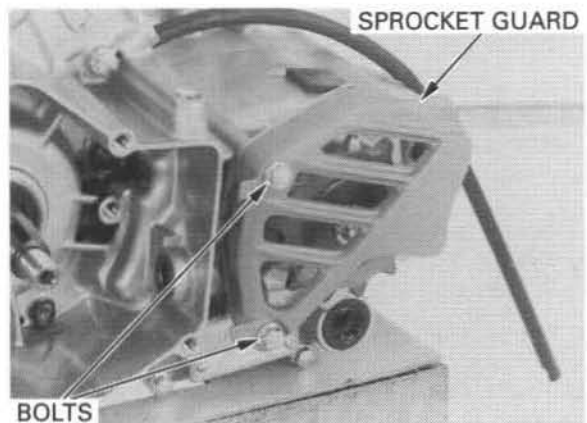

Loosen the drive sprocket bolt while holding the sprocket with the universal holder.

TOOL:

Universal holder 07725 - 0030000

Remove the cone spring washer and drive sprocket.



Temporarily install the clutch outer guide, needle bearing and clutch outer onto the mainshaft.

Insert the gear holder between the primary drive and driven gear.

Remove the primary drive gear bolt, then remove the washer and drive gear.

TOOL:

Gear holder 07724 - 0010200 Not available in U.S.A.

Check the primary drive gear for wear or damage.

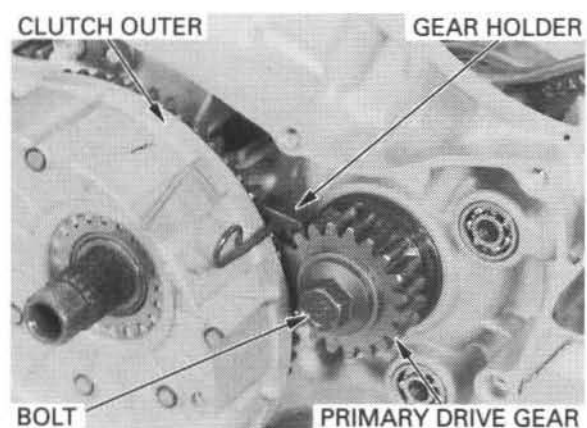

Remove the clutch outer, needle bearing and outer guide.

Remove the collar from the crankshaft.

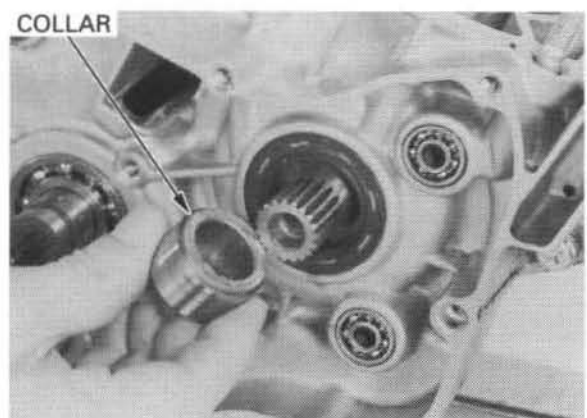

Remove the countershaft collar and O-ring.

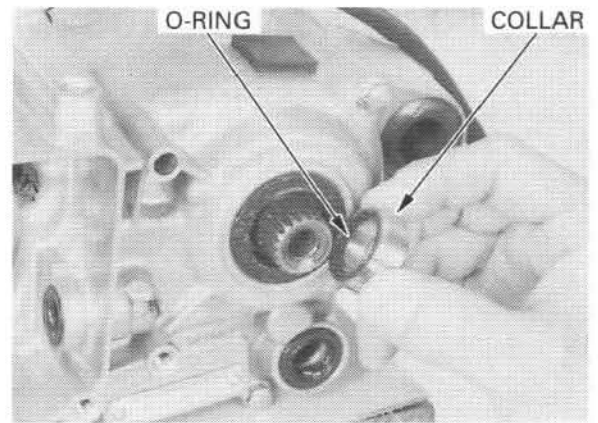

Loosen the crankcase bolts in a crisscross pattern in two or three steps.
Remove the ten crankcase bolts.

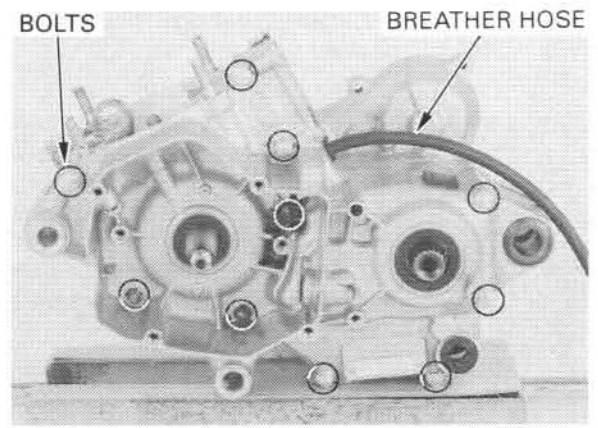

Attach the crankcase puller and 6 X 100 mm bolts with large washer to the left crankcase and separate the crankcase halves.

NOTE:

Separate the right and left crankcase from each other while tapping them at several locations with a soft hammer.

CAUTION:

Do not pry the crankcase halves apart with a screwdriver.

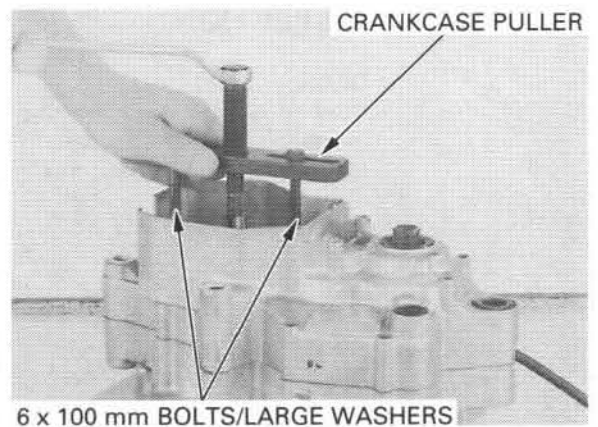

TOOLS:

Crankcase puller

07937 - 4300001 or
07937 - 4300000 or
07631 - 0010000
use with 6 x 100 mm
bolts and large
washers

Remove the gaskets, breather hose and dowel pins.

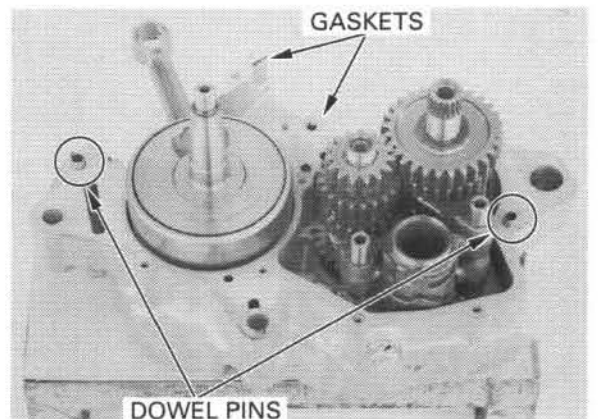

TRANSMISSION DISASSEMBLY

DISASSEMBLY

Separate the crankcase halves (page 10-4).

Remove the shift fork shafts and shift forks.

Remove the shift drum.

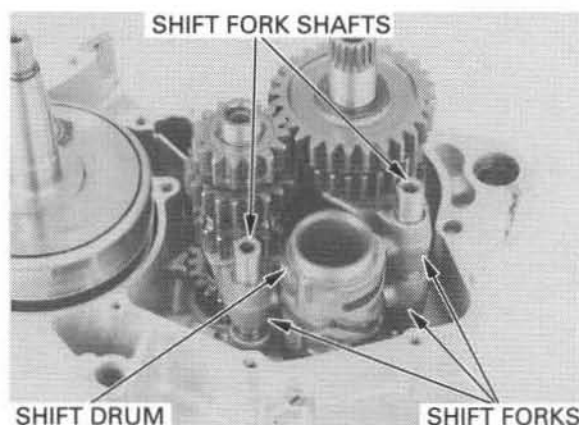

Remove the mainshaft and countershaft assemblies as a set.

NOTE:

- Keep track of the disassembled parts (gears, bushings, washers, and snap rings) by stacking them on a tool onto a piece of wire.
- Do not remove the snap ring by spreading the ends and sliding off shaft, instead expand the snap ring and pull it off using the gear behind it.

Disassemble the mainshaft and countershaft.

MAINSHAFT/COUNTERSHAFT ASSEMBLY

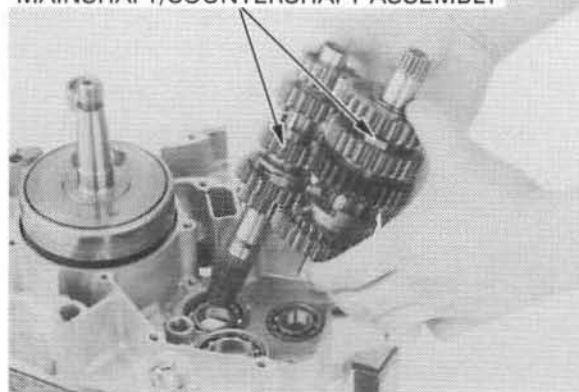

INSPECTION

GEAR

Check the gear dogs, dog holders and teeth for damage or excessive wear.

Measure the I.D. of each gear.

SERVICE LIMITS: M4, M5: 23.06 mm (0.908 in)
C1: 20.06 mm (0.790 in)
C2, C3: 25.06 mm (0.987 in)

BUSHING

Check the bushings for damage or excessive wear.
Measure the O.D. of each bushing.

SERVICE LIMITS: M4, M5: 22.95 mm (0.904 in)
C1: 19.95 mm (0.785 in)
C2, C3: 24.95 mm (0.982 in)

Measure the I.D. of each bushing.

SERVICE LIMITS: M5: 20.04 mm (0.789 in)
C1: 17.03 mm (0.670 in)
C2, C3: 22.04 mm (0.868 in)

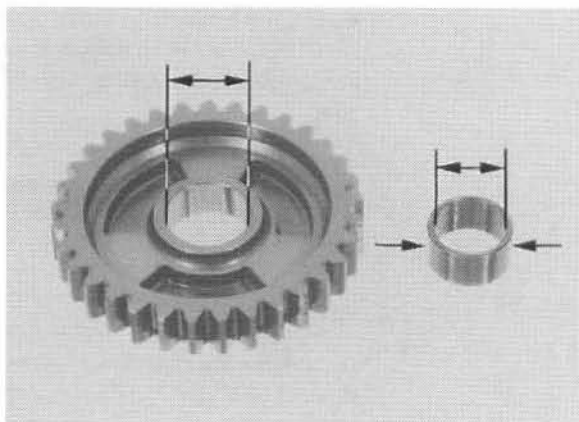

MAINSHAFT/COUNTERSHAFT

Check the spline grooves and sliding surfaces for damage or abnormal wear.
Measure the O.D. of the mainshaft and countershaft at the gear and bushing sliding area.

SERVICE LIMITS:

Mainshaft: M5:	19.94 mm (0.785 in)
Countershaft:	
C1 bushing:	16.97 mm (0.668 in)
C2 bushing:	21.94 mm (0.864 in)
C3 bushing:	21.94 mm (0.864 in)
Starter idle gear:	16.97 mm (0.668 in)

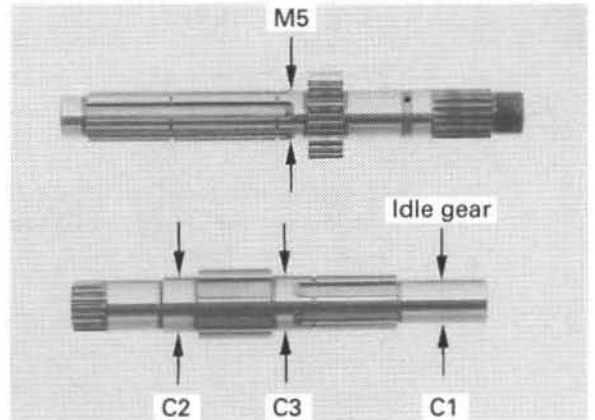

SHIFT FORK

Check the shift fork for abnormal wear or deformation.
Measure the shift fork I.D. and claw thickness.

SERVICE LIMITS:

I.D.:	11.065 mm (0.4356 in)
Claw thickness:	4.8 mm (0.19 in)

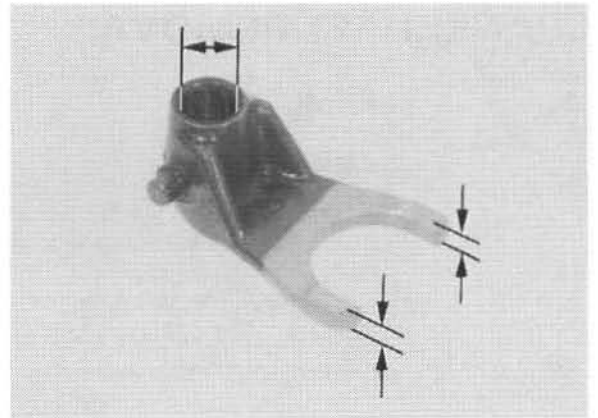

SHIFT FORK SHAFT

Check the shift fork shaft for abnormal wear or deformation.
Measure the shift fork shaft O.D.

SERVICE LIMIT: 10.973 mm (0.4320 in)

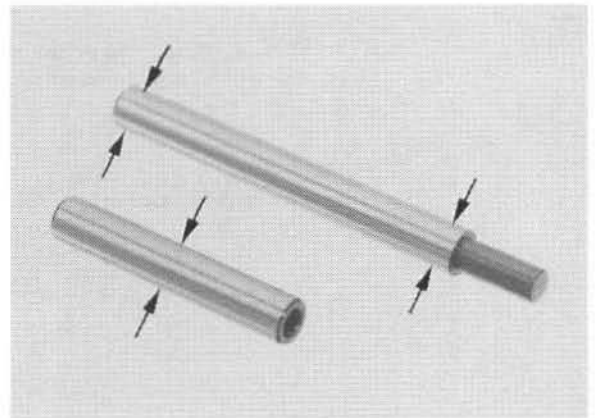

SHIFT DRUM

Inspect the shift drum for scoring, scratches or evidence of insufficient lubrication.
Check the shift drum grooves for abnormal wear or damage.

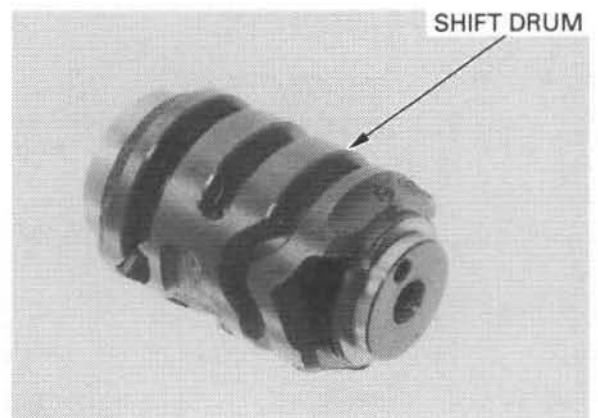

TRANSMISSION BEARING

Turn the inner race of each bearing with your finger. The bearings should turn smoothly and quietly. Also check that the bearing outer race fits tightly in the crankcase.

Replace the bearings if the race does not turn smoothly and quietly, or if they fit loosely in the crankcase (page 10-7).

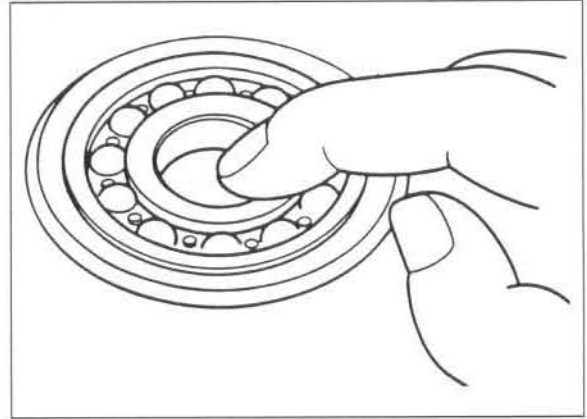

CRANKSHAFT REMOVAL

REMOVAL

CAUTION:

When removing, installing and inspecting the crankshaft, be careful not to damage or nick the hollow crank weight.

Separate the crankcase (page 10-4).
Remove the transmission (page 10-6).

Remove the crankshaft from the right crankcase using a hydraulic press as shown.

If the crankshaft bearing is removed with the crankshaft, remove the bearing using the bearing puller and discard the bearing.

TOOL:

Universal bearing puller

07631 - 0010000 or equivalent commercially available in U.S.A.

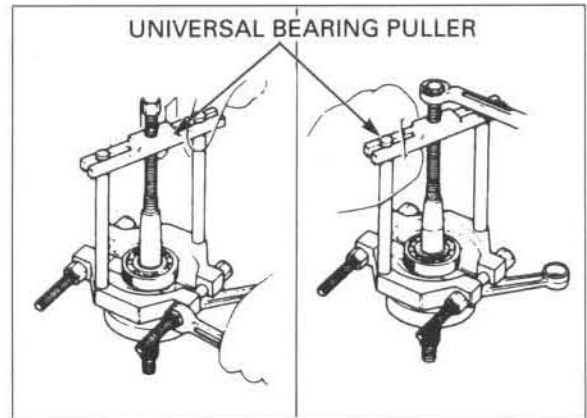
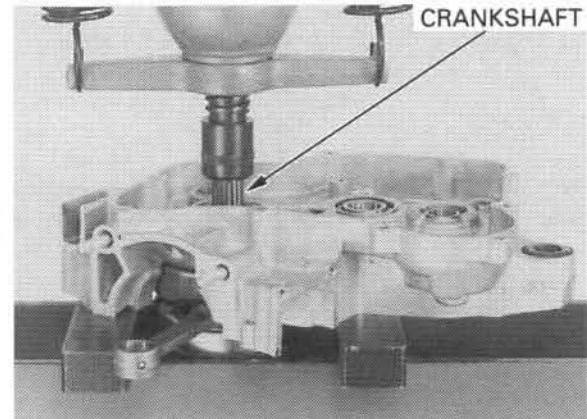

INSPECTION

Place the crankshaft on a stand or V-blocks. Set the indicator on the main journal. Rotate the crankshaft two revolutions and read the runout.

SERVICE LIMIT: 0.05 mm (0.002 in)

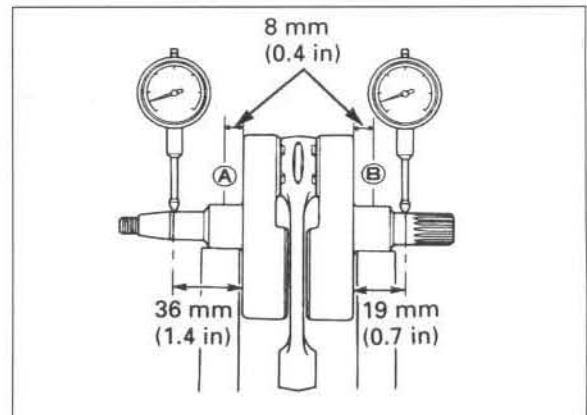

Measure the connecting rod big end axial/radial play by moving the rod in the appropriate direction after zeroing the gauge.

SERVICE LIMIT: 0.032 mm (0.0013 in)

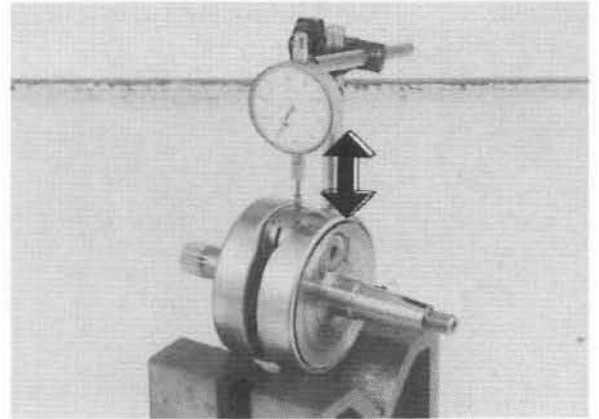

Measure the connecting rod big end side clearance.

SERVICE LIMIT: 0.9 mm (0.04 in)

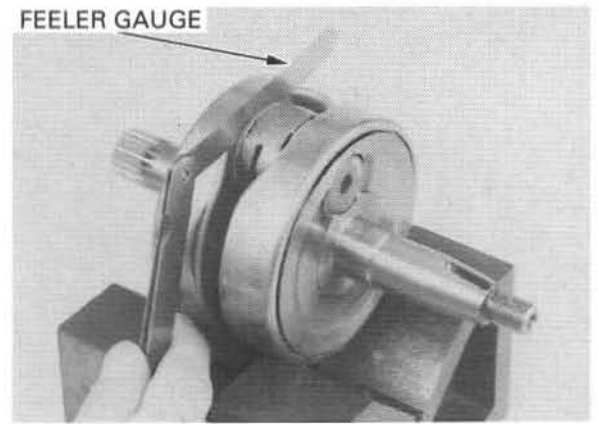

CRANKCASE BEARING REPLACEMENT

CRANKCASE BEARING/OIL SEAL LOCATION

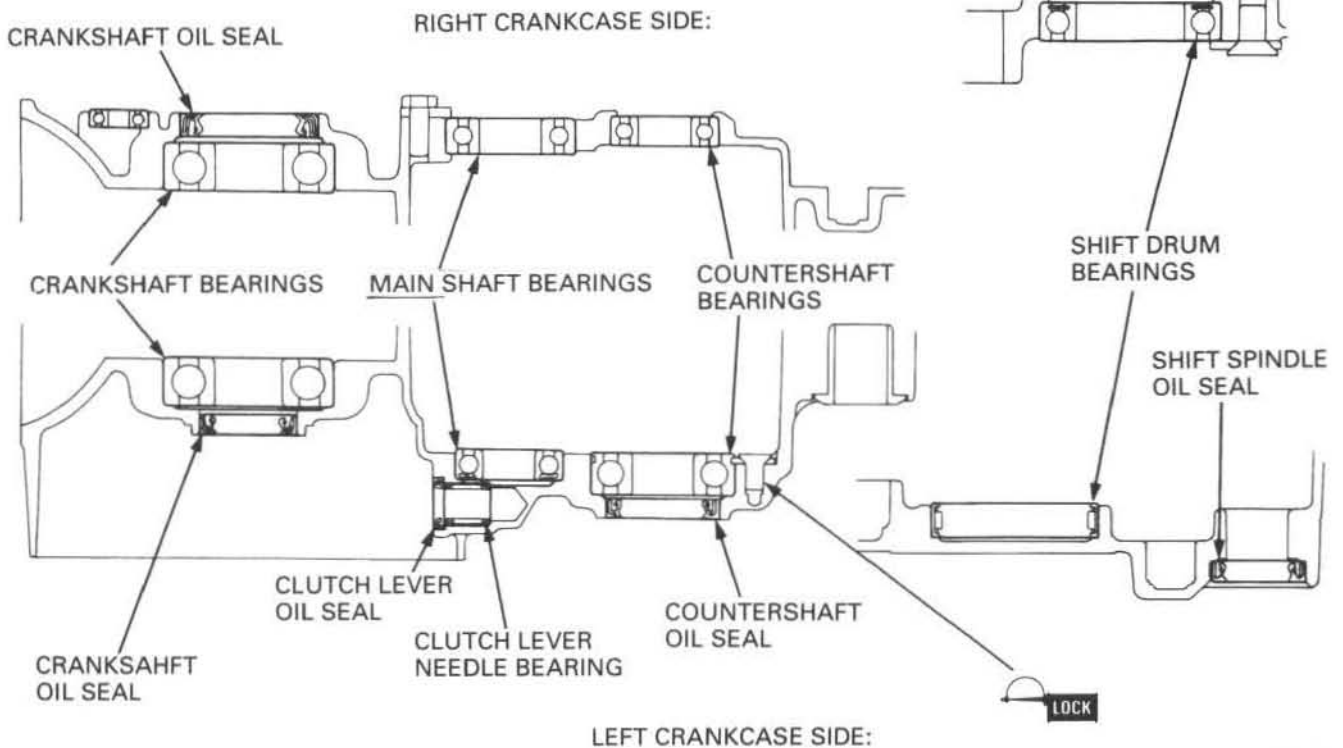

CRANKSHAFT BEARING

Remove the crankshaft oil seals and bearings from both crankcase halves.

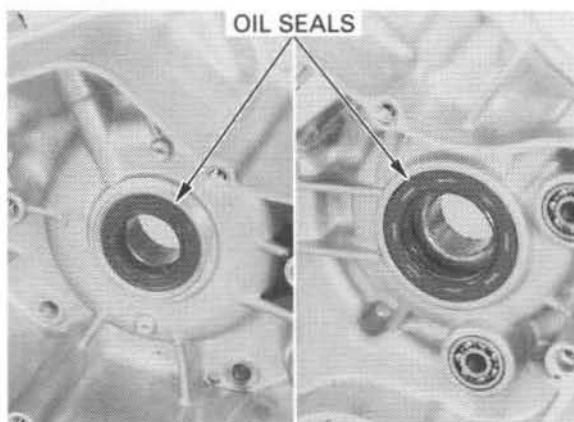

Drive in the new bearings squarely.

Drive in the new crankshaft bearings into both crankcase using the special tools as shown.

TOOLS:

Driver	07749 - 0010000
Attachment, 52 x 55 mm	07746 - 0010400
Pilot, 22 mm	07746 - 0041000

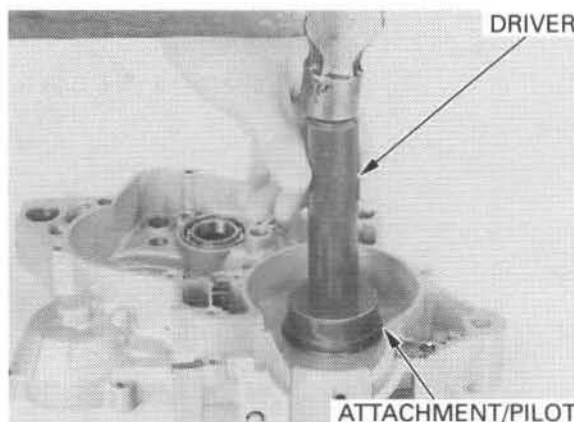

TRANSMISSION BEARINGS

LEFT CRANKCASE

Remove the countershaft oil seal.

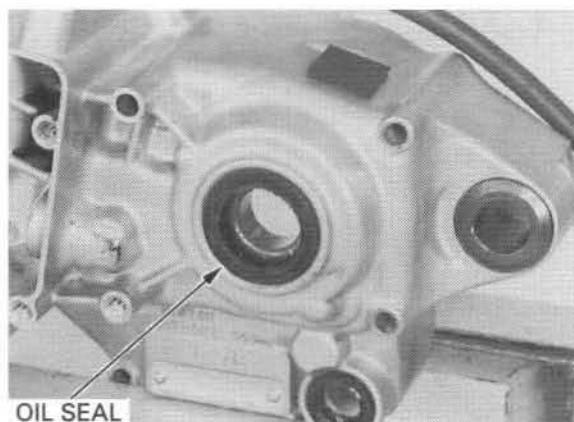

Remove the screws and countershaft bearing set plates.

Remove the countershaft bearing and shift drum bearing.

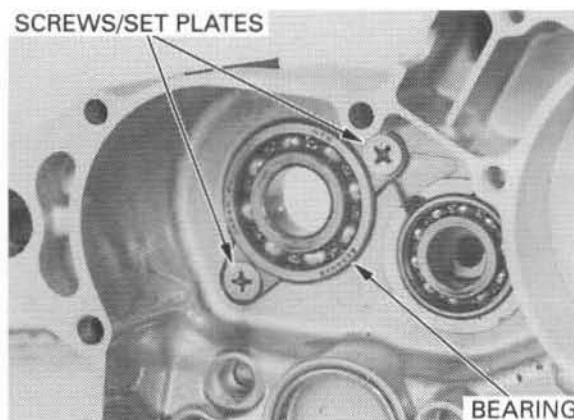

Remove the mainshaft bearing using the special tools as shown.

TOOLS:

- | | |
|-------------------------------|---|
| Bearing remover, 17 mm | 07936 - 3710300 |
| - Remover handle | 07936 - 3710100 |
| - Remover weight | 07741 - 0010201 or
07936 - 371020A or
07936 - 3710200 |

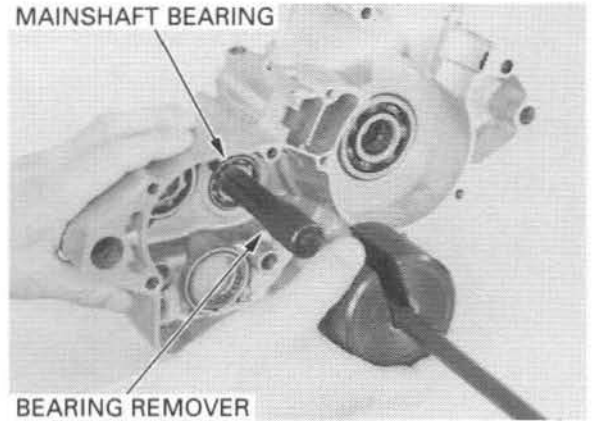

Drive in the new bearings squarely. Drive in new bearings into the left crankcase using the special tools as shown.

TOOLS:

- | | |
|----------------------------|-----------------|
| Shift drum bearing: | |
| Driver | 07749 - 0010000 |
| Attachment, 37 x 40 mm | 07746 - 0010200 |

- | | |
|---------------------------|-----------------|
| Mainshaft bearing: | |
| Driver | 07749 - 0010000 |
| Attachment, 37 x 40 mm | 07746 - 0010200 |
| Pilot, 17 mm | 07746 - 0040400 |

- | | |
|------------------------------|-----------------|
| Countershaft bearing: | |
| Driver | 07749 - 0010000 |
| Attachment, 42 x 47 mm | 07746 - 0010300 |
| Pilot, 20 mm | 07746 - 0040500 |

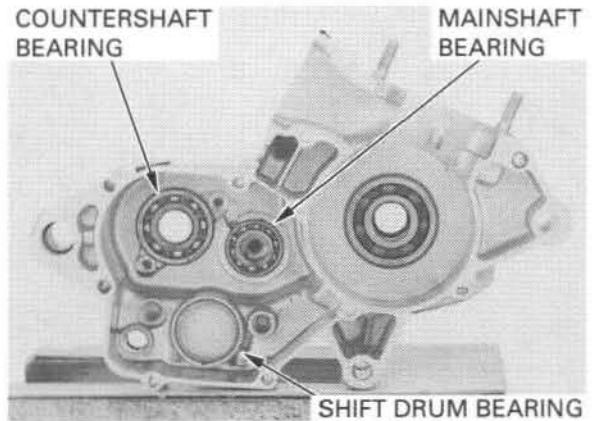
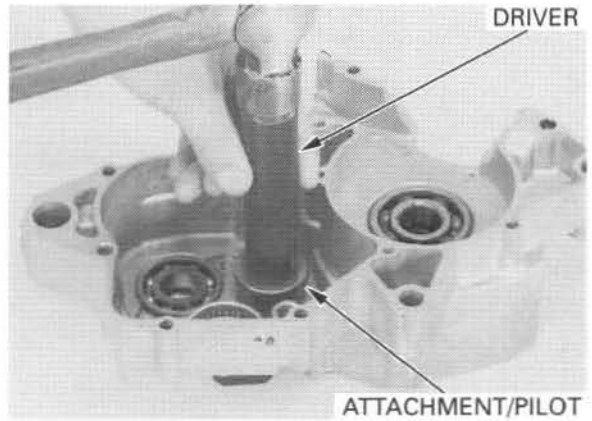

Clean and apply a locking agent to the countershaft bearing set plate screws and tighten the screws with the set plates.

TORQUE: 10 N·m (1.0 kgf·m, 7 lbf·ft)

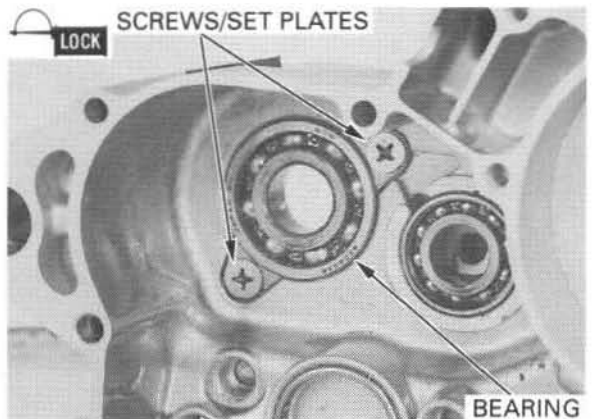

CRANKCASE/CRANKSHAFT/TRANSMISSION

Apply grease to the countershaft oil seal lips.
Install the countershaft oil seal flush with the case as shown.

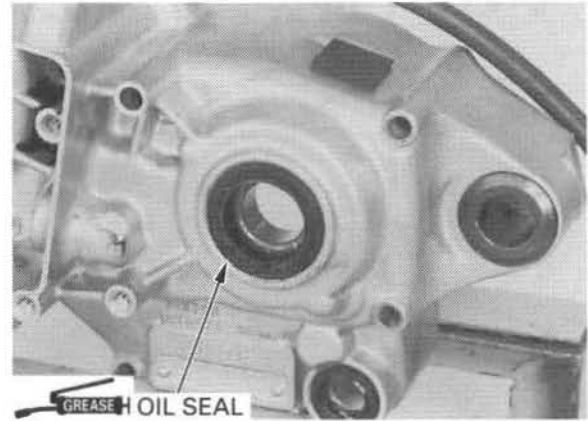

RIGHT CRANKCASE

Remove the mainshaft and countershaft bearings.

Remove the shift drum bearing set plate bolts and set plates.

Remove the shift drum bearing.

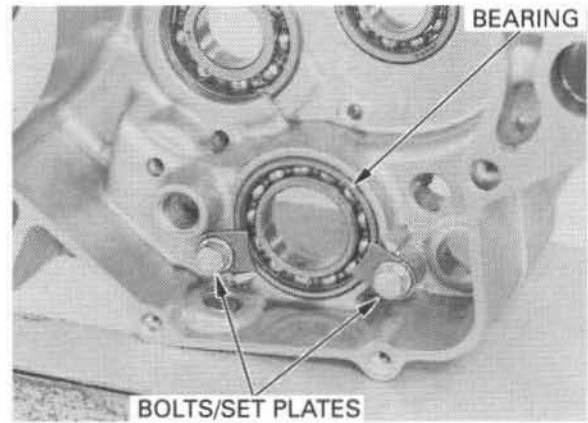

Drive in the new bearings squarely.

Drive in new bearings into the right crankcase.

TOOLS:

Shift drum bearing:

Driver	07749 - 0010000
Attachment, 37 x 40 mm	07746 - 0010200
Pilot, 25 mm	07746 - 0040600

Mainshaft bearing:

Driver	07749 - 0010000
Attachment, 42 x 47 mm	07746 - 0010300
Pilot, 20 mm	07746 - 0040500

Countershaft bearing:

Driver	07749 - 0010000
Attachment, 37 x 40 mm	07746 - 0010200
Pilot, 17 mm	07746 - 0040400

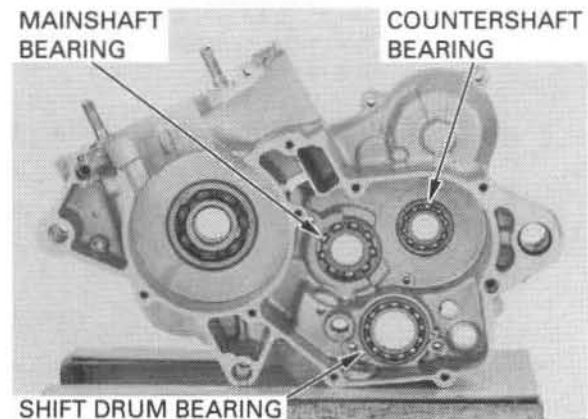
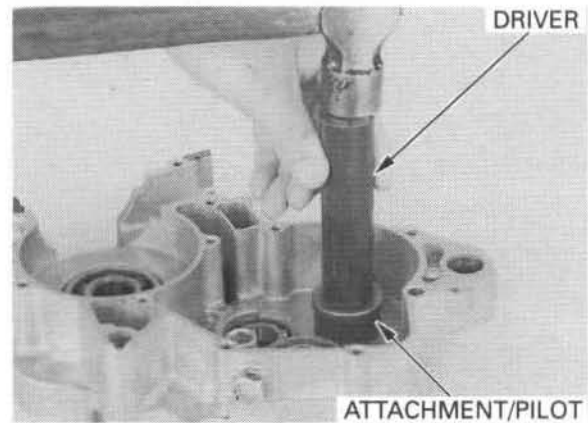

Clean and apply a locking agent to the shift drum bearing set plate bolts and tighten the bolts with the set plates.

TORQUE: 10 N·m (1.0 kgf·m, 7 lbf·ft)

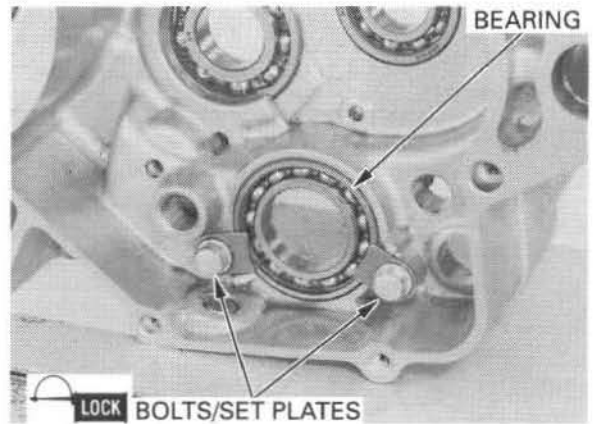

CRANKSHAFT INSTALLATION

Clean both crankcase mating surfaces before assembling and check for wear or damage.

NOTE:

- If there is minor roughness or irregularities on the crankcase mating surfaces, dress them with an oil stone.
- After cleaning, lubricate the crankshaft bearings with recommended clean 2-stroke oil.

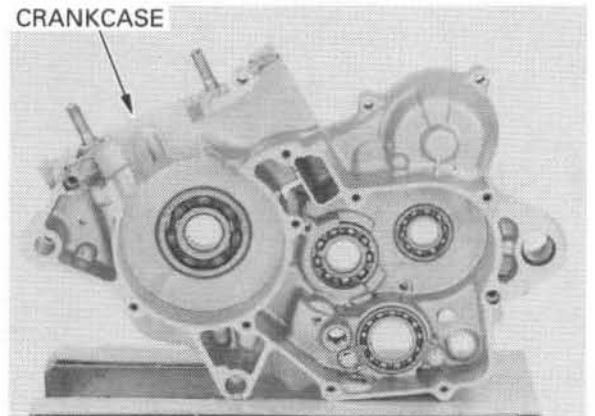

Install the threaded adapter on to the crankshaft.

TOOL:

Threaded adapter 07965 - KA30000

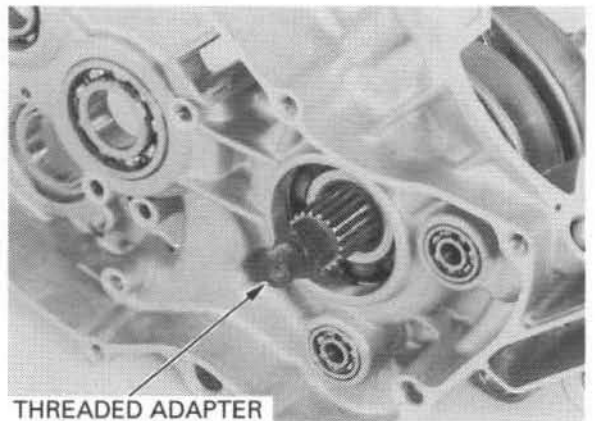

Install the crankshaft into the right crankcase using the special tools.

TOOLS:

Crankcase assembly tool set 07965 - 1660102 Not available in U.S.A. or 07965 - 1660101 or 07965 - 1660100

- Assembly tool shaft 07965 - 1660200

- Assembly collar 07965 - 1660302 or 07965 - 1660301 or 07965 - 1660300 or 07965 - 166030A (U.S.A. only)



TRANSMISSION ASSEMBLY

NOTE:

- Check the gear freedom of movement or rotation on the shaft.
- Install the washers and snap rings with the chamfered edge facing the thrust load side.
- Do not reuse worn snap rings which could easily spin in the grooves.
- Check that the snap rings are seated in the grooves. Align their end gaps with the grooves of the spline.

Clean all parts in solvent.
Assemble all parts into original positions.

MAINSHAFT:

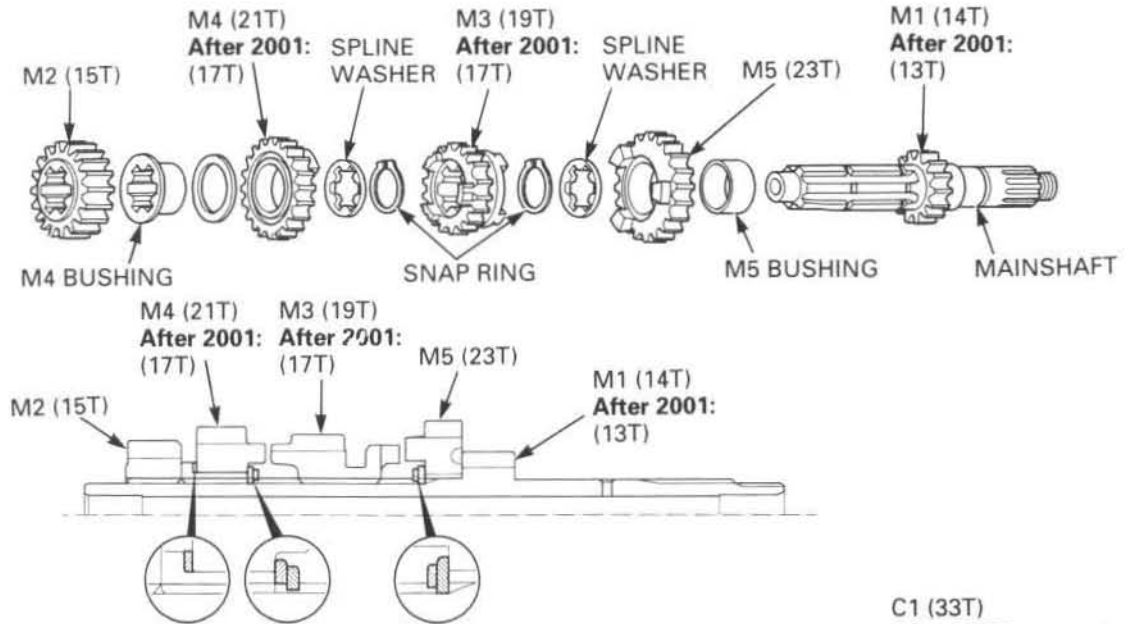

COUNTERSHAFT:

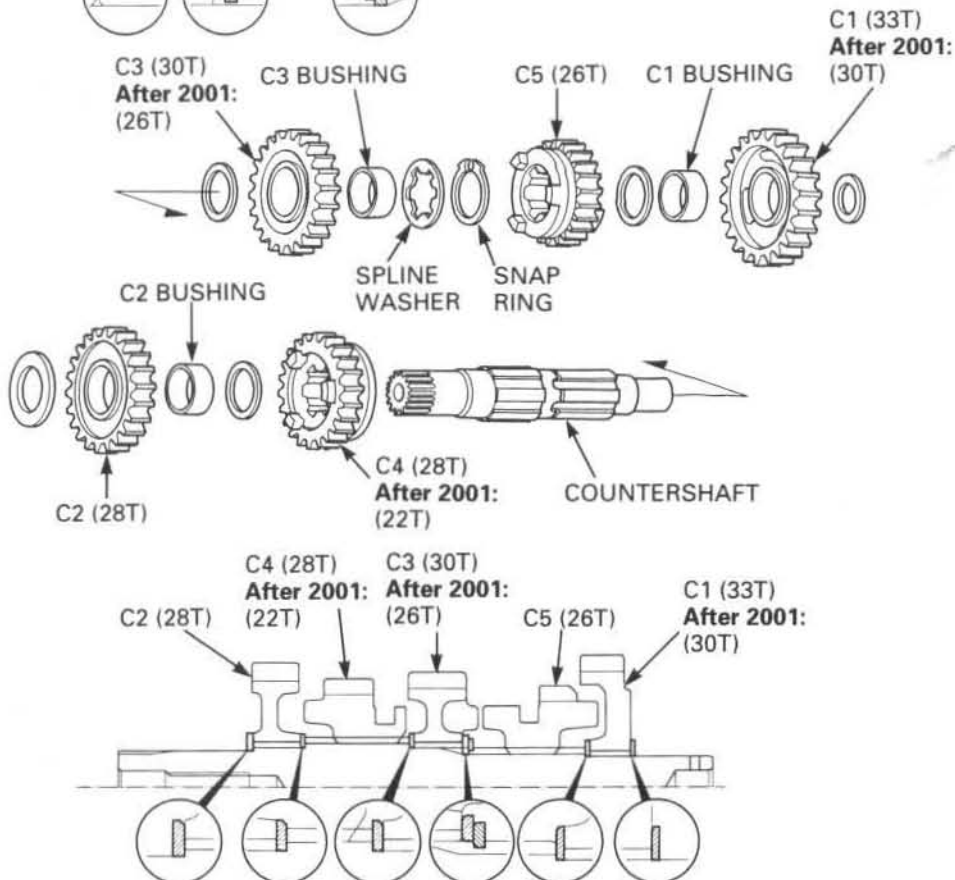

Apply transmission oil to the following parts:

- Mainshaft
- Countershaft
- Each gear
- Mainshaft bearing
- Countershaft bearing
- Shift drum bearing

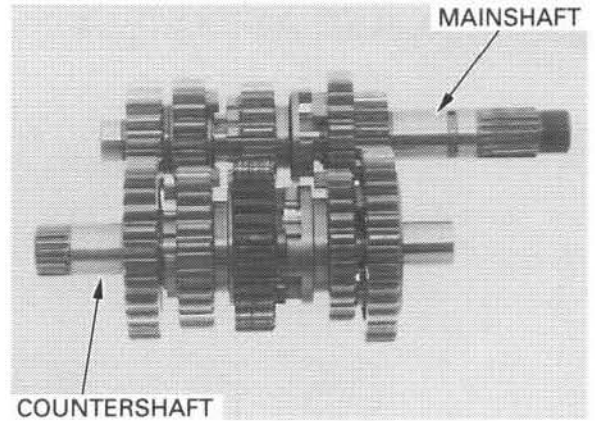

Engage the mainshaft and countershaft gears and place the transmission assembly into the right crankcase.

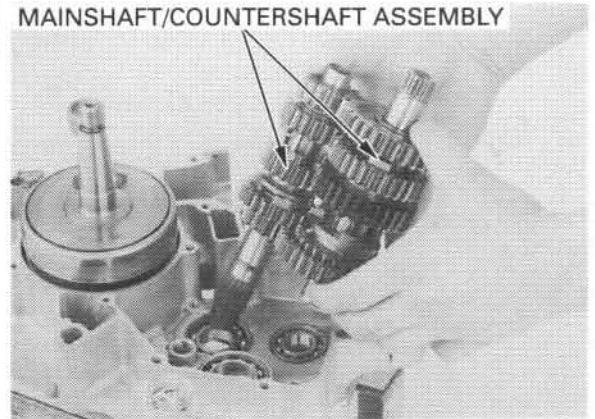

Install the shift forks into the shifter gear grooves.

NOTE:

- Each shift fork has an identification mark, "R" (three marks) is for the right shift fork, "L" is the left shift fork and "C" is for the center shift fork.
 - Face the shift fork marks as toward the left crankcase.
- All marks face left crankcase.

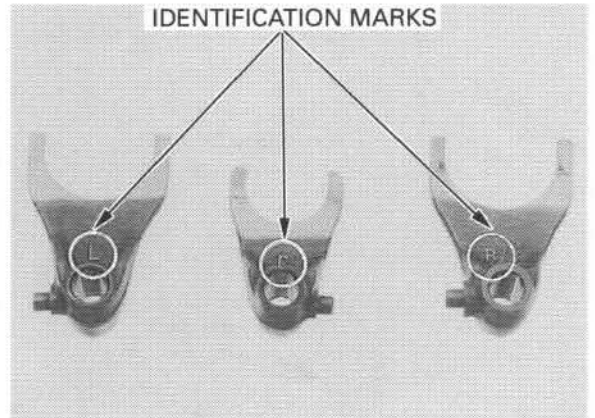

Apply transmission oil to the following parts:

- Shift drum guide grooves
- Shift fork claws and guide pins
- Shift fork sliding surfaces
- Shift fork shaft

Install the shift forks to the grooves of the shifter gear.

Install the shift drum by aligning the guide pins on the shift forks with the guide grooves of the shift drum.

Slide the shift fork shafts through the shift forks, and into the crankcase.

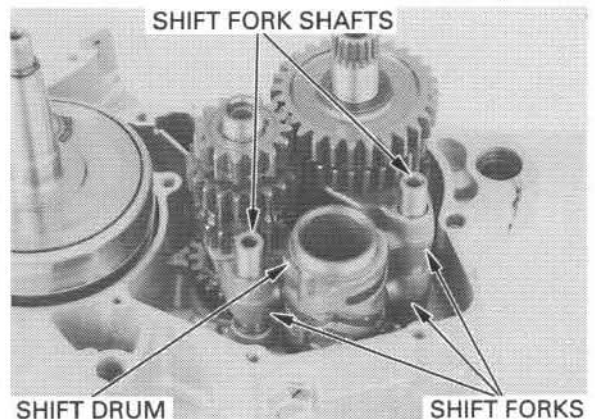

CRANKCASE ASSEMBLY

NOTE:

Before assembly, lubricate the transmission bearings with clean transmission oil.

Install the dowel pins and new gaskets.

Install the crankcase breather hose onto the left crankcase.

Place the left crankcase onto the right crankcase using the special tools as shown.

TOOLS:

Crankcase assembly tool set 07965 - 1660102 Not available in U.S.A. or 07965 - 1660101 or 07965 - 1660100
 - Assembly tool shaft 07965 - 1660200
 - Assembly collar 07965 - 1660302 or 07965 - 1660301 or 07965 - 1660300 or 07965 - 166030A (U.S.A. only)

Pack grease into the cavity between the oil seal lips.

Press the oil seals into the crankcase using the crankcase assembly tool until seals are flush with the case as shown.

TOOLS:

Left crankshaft oil seal:
Crankcase assembly tool set 07965 - 1660102 Not available in U.S.A. or 07965 - 1660101 or 07965 - 1660100
 - Assembly tool shaft 07965 - 1660200
 - Assembly collar 07965 - 1660302 or 07965 - 1660301 or 07965 - 1660300 or 07965 - 166030A (U.S.A. only)

Right crankshaft oil seal:
Threaded adapter 07965 - KA30000 or
Threaded adapter, 10 x 12.5 x 16 x 15 07VMF - HM8010A
Assembly collar 07965 - VM00100
Threaded shaft 07965 - VM00200 or
Assembly shaft 07931 - ME4010B and
Special nut 07931 - HB3020A (U.S.A. only)

Tighten the crankcase bolts in a crisscross pattern in two or three progressive steps.

Carefully trim the protruding gasket material from the cylinder base gasket surface.

CAUTION:

- Do not let gasket material fall into the crankcase.
- Do not damage the base gasket surface.

Check that the crankshaft turns smoothly.

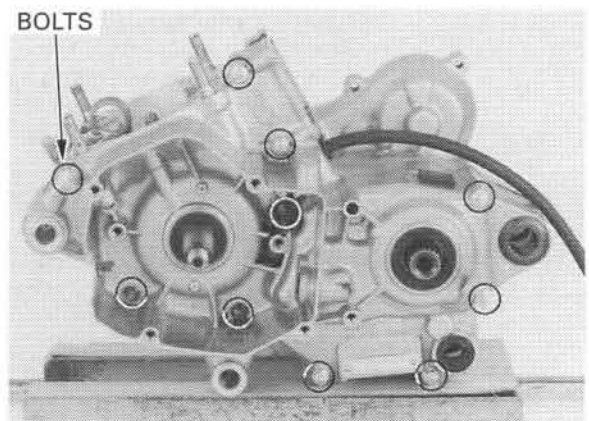
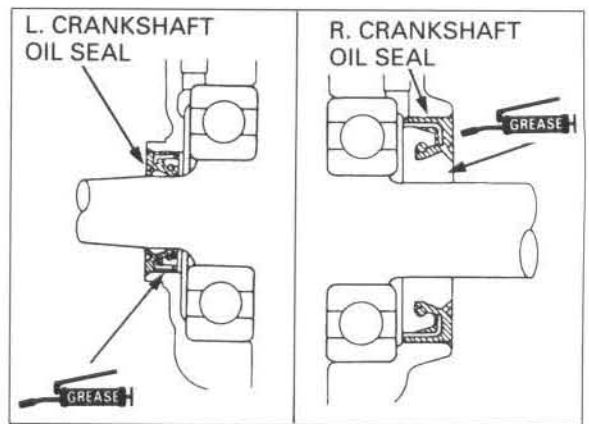
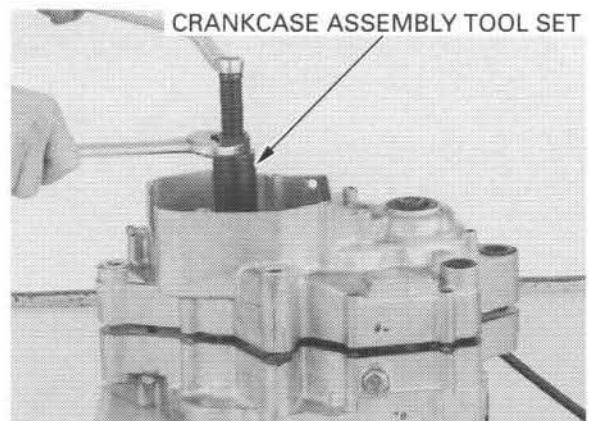
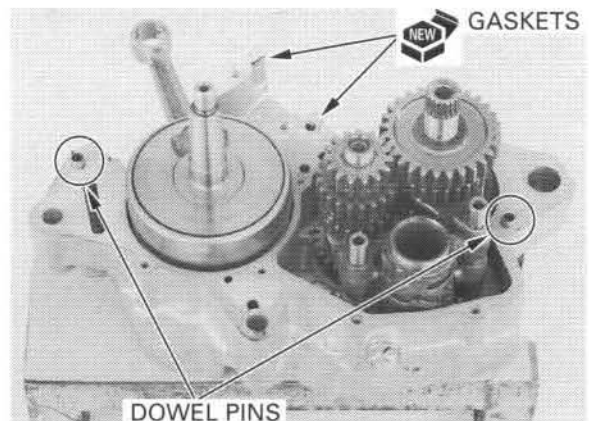

Coat the countershaft O-ring and the inside of the countershaft collar with grease.
Install the O-ring and collar onto the countershaft.

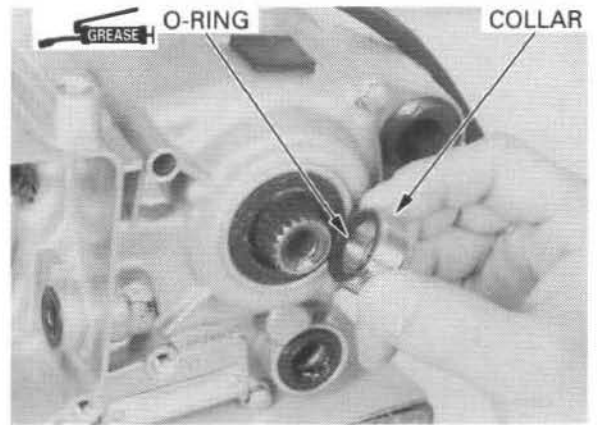

Install the drive sprocket onto the countershaft as described below.

CAUTION:

Install the drive sprocket with its flat side facing the outside.

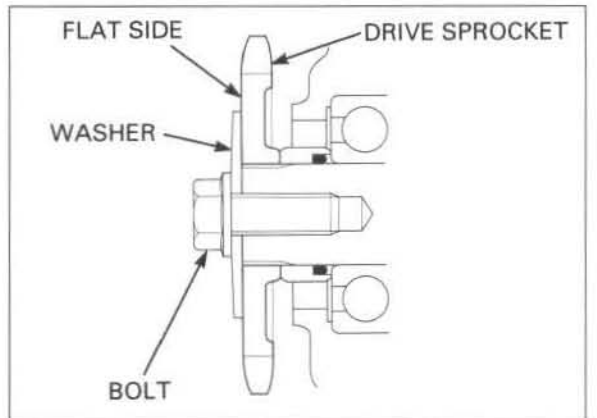

Install the cone washer with the "OUT SIDE" mark facing out.
Hold the drive sprocket with the universal holder and install and tighten the sprocket bolt to the specified torque.

TOOL:

Universal holder 07725 - 0030000

TORQUE: 26 N·m (2.7 kgf·m, 20 lbf·ft)

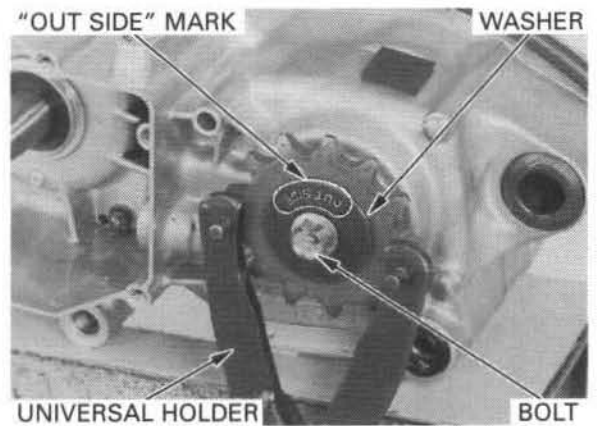

Install the drive sprocket guard and tighten the bolts.

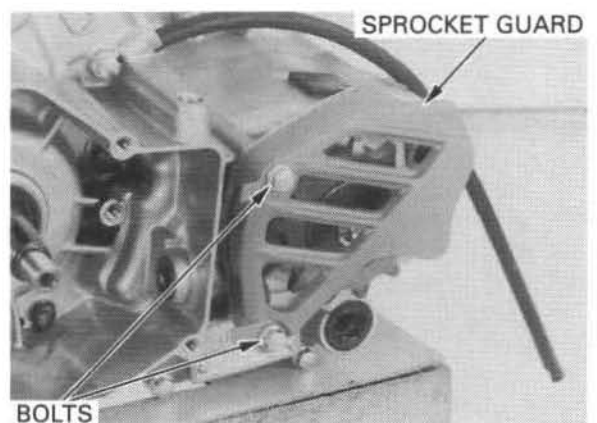

CRANKCASE/CRANKSHAFT/TRANSMISSION

Install the collar onto the crankshaft.

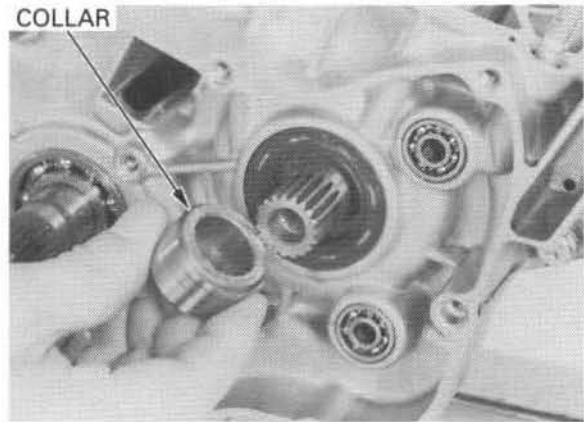

Install the primary drive gear, bolt and washer.

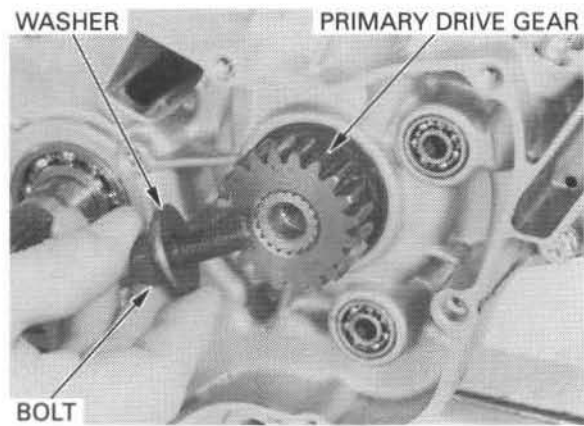

Temporarily install the clutch outer guide, needle bearing and clutch outer guide.

Attach the gear holder between the primary drive and driven gear.

TOOL:

Gear holder

07724 - 0010200 Not available in U.S.A.

Tighten the primary drive gear bolt to the specified torque.

TORQUE: 64 N·m (6.5 kgf·m, 47 lbf·ft)

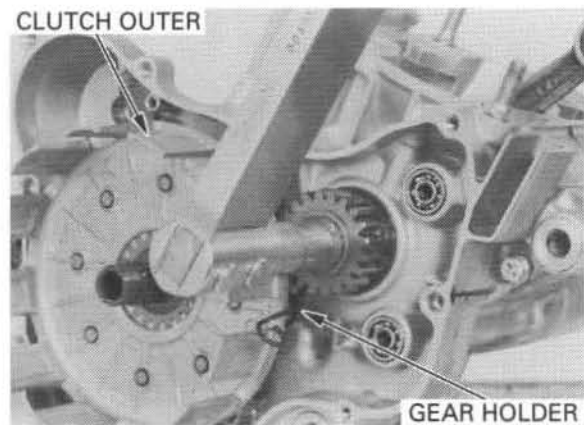

Install the remaining parts in the reverse order of removal.

NOTE:

Refer to Service Information (page 10-1) for installation of parts removed to perform crankcase/transmission service.

Start the engine and check for leaks from the inspection hole.

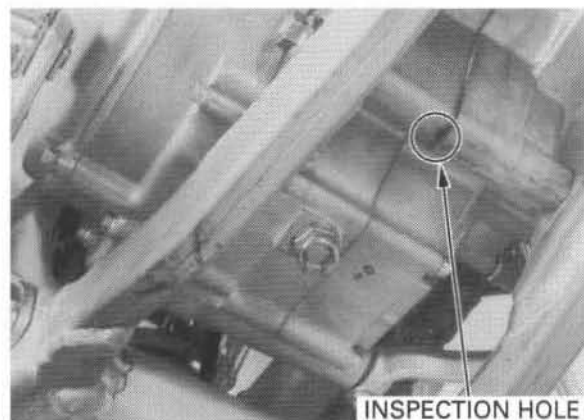

MEMO

FRONT WHEEL/SUSPENSION/STEERING

2000:
 147 N·m (15.0 kgf·m,
 108 lbf·ft)
After 2000:
 108 N·m (11.0 kgf·m,
 80 lbf·ft)

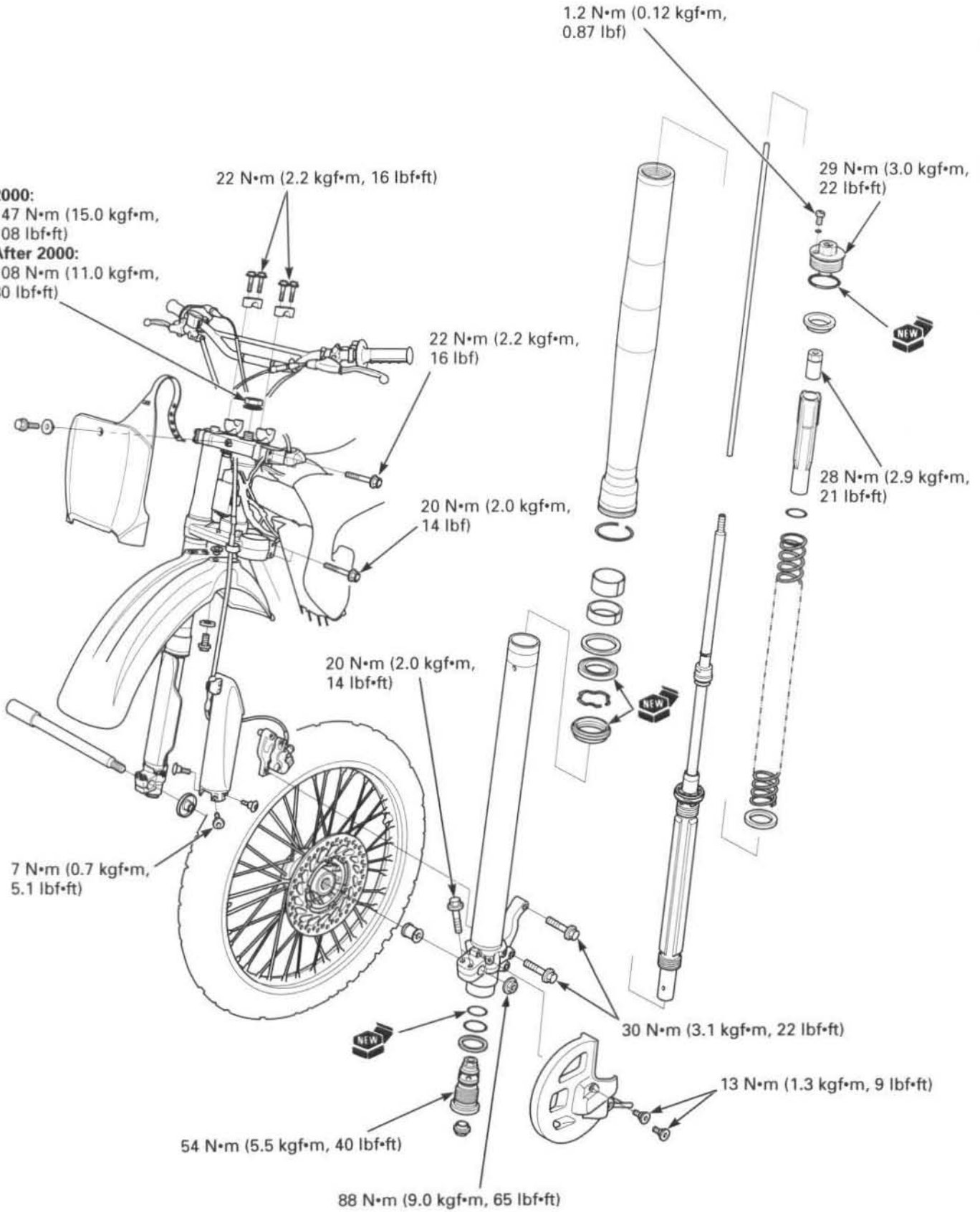

11. FRONT WHEEL/SUSPENSION/STEERING

SERVICE INFORMATION	11-1	FORK	11-9
TROUBLESHOOTING	11-3	HANDLEBAR	11-24
FRONT WHEEL	11-4	STEERING STEM	11-29

SERVICE INFORMATION

GENERAL

Keep grease off of brake pads and disc.

⚠ WARNING

A contaminated brake disc or pad reduces stopping power. Discard contaminated pads and clean a contaminated disc with a high quality brake degreasing agent.

- This section covers maintenance of the front wheel, fork and steering stem.
- When servicing the front wheel, fork or steering stem, support the motorcycle using a safety stand or hoist.
- Optional lighter and heavier than standard springs are available. Refer to General Information, Section 1 for details.
- For optimum performance, the fork should be completely disassembled and cleaned after the first 3 hours of riding. Thereafter it should be disassembled and cleaned on a regular basis to ensure maximum performance and service life from the internal parts.
- Refer to section 13 for brake system information.

11

SPECIFICATIONS

Unit: mm (in)

ITEM		STANDARD		SERVICE LIMIT
Cold tire pressure		100 kPa (1.0 kgf/cm ² , 14 psi)		—
Axle runout		—		0.20 (0.008)
Wheel rim runout	Radial	—		2.0 (0.08)
	Axial	—		2.0 (0.08)
Wheel hub-to-rim distance		27.25 (1.073)		—
Fork	Spring free length	2000:	470.0 (18.50)	467 (18.4)
		After 2000:	483.0 (19.02)	480 (18.9)
Tube runout		—		0.2 (0.01)
Recommended fork fluid		Pro-Honda HP Fork Oil 5W or equivalent		—
Fluid level		2000:	60 (2.4)	—
		2001:	59 (2.3)	—
		After 2001:	98 (3.9)	—
Fluid capacity		2000:	518 cm ³ (17.5 US oz, 18.2 Imp oz)	—
		2001:	502 cm ³ (17.0 US oz, 17.7 Imp oz)	—
		After 2001:	475 cm ³ (16.1 US oz, 16.7 Imp oz)	—
Compression damping adjuster standard position		2000:	11 clicks out from full in	—
		2001:	9 clicks out from full in	—
		After 2001:	8 clicks out from full in	—
Rebound damping adjuster standard position		2000 – 2001:	9 clicks out from full in	—
		After 2001:	12 clicks out from full in	—

FRONT WHEEL/SUSPENSION/STEERING

TORQUE VALUES

Front axle nut	88 N•m (9.0 kgf•m, 65 lbf•ft)	
Front axle holder bolt	20 N•m (2.0 kgf•m, 14 lbf•ft)	
Front spoke nipple	4 N•m (0.4 kgf•m, 3.0 lbf•ft)	
Front rim lock	13 N•m (1.3 kgf•m, 9 lbf•ft)	
Front brake disc nut	16 N•m (1.6 kgf•m, 12 lbf•ft)	U-nut.
Steering stem nut (2000)	147 N•m (15.0 kgf•m, 108 lbf•ft)	
(After 2000)	108 N•m (11.0 kgf•m, 80 lbf•ft)	
Steering stem adjust nut	7 N•m (0.7 kgf•m, 5.1 lbf•ft)	
Front brake hose guide bolt	5 N•m (0.5 kgf•m, 3.6 lbf•ft)	
Fork tube pinch bolt (top)	22 N•m (2.2 kgf•m, 16 lbf•ft)	
(bottom)	20 N•m (2.0 kgf•m, 14 lbf•ft)	
Fork cap	29 N•m (3.0 kgf•m, 22 lbf•ft)	
Fork cap lock nut	28 N•m (2.9 kgf•m, 21 lbf•ft)	
Fork center bolt	54 N•m (5.5 kgf•m, 40 lbf•ft)	Apply a locking agent to the threads.
Fork protector mounting bolt	7 N•m (0.7 kgf•m, 5.1 lbf•ft)	Apply a locking agent to the threads.
Front brake disc cover bolt	13 N•m (1.3 kgf•m, 9 lbf•ft)	
Front caliper mounting bolt	30 N•m (3.1 kgf•m, 22 lbf•ft)	Apply a locking agent to the threads.
Fork air pressure release screw	1.2 N•m (0.12 kgf•m, 0.87 lbf•ft)	
Handlebar upper holder bolt	22 N•m (2.2 kgf•m, 16 lbf•ft)	
Clutch lever pivot bolt	2 N•m (0.2 kgf•m, 1.4 lbf•ft)	
Clutch lever pivot nut	10 N•m (1.0 kgf•m, 7 lbf•ft)	
Clutch lever holder bolt	9 N•m (0.9 kgf•m, 6.5 lbf•ft)	
Throttle housing bolt	9 N•m (0.9 kgf•m, 6.5 lbf•ft)	
Throttle housing cover screw	2 N•m (0.2 kgf•m, 1.4 lbf•ft)	
Engine stop button screw	2 N•m (0.2 kgf•m, 1.4 lbf•ft)	

TOOLS

Spoke wrench, 5.8 x 6.1 mm	07701 - 0020300	or equivalent commercially available in U. S. A.
Attachment, 37 x 40 mm	07746 - 0010200	
Attachment, 30 mm I. D.	07746 - 0030300	
Pilot, 20 mm	07746 - 0040500	
Bearing remover shaft	07746 - 0050100	
Bearing remover head, 20 mm	07746 - 0050600	
Driver	07749 - 0010000	
Steering stem socket	07916 - 3710101	or 07702 - 0020001
Ball race remover	07946 - 3710500	or 07949 - 3710001 and 07946 - 1870100
Fork rod holder handle	07TMB - 001010A	
Fork seal driver, 46 mm	07TMD - MAC0100	or 07TMD - MAC010A
Bearing race installer	07VMF - KZ30100	
Installer shaft	07VMF - KZ30200	
Fork rod holder attachment, 32 mm	07YMB - KZ40100	

TROUBLESHOOTING

Hard steering

- Steering adjusting nut too tight
- Faulty or damaged steering head bearings
- Insufficient tire pressure

Steers to one side or does not track straight

- Bent fork tube
- Bent axle
- Wheel installed incorrectly
- Unequal oil quantity in each fork tube
- Faulty steering head bearings
- Bent frame
- Worn wheel bearing
- Worn swingarm pivot components
- Unevenly adjusted right and left fork legs

Front wheel wobbling

- Bent rim
- Worn front wheel bearings
- Bent spokes
- Faulty tire
- Axle not tightened properly
- Unbalanced tire and wheel

Wheel turns hard

- Faulty wheel bearing
- Bent front axle
- Brake drag

Soft suspension

- Insufficient fluid fork
- Fork oil viscosity too high
- Weak fork springs
- Tire pressure too low

Hard suspension

- Excess fork oil
- Fork oil viscosity too thick
- Bent or damage fork tubes
- Clogged fork fluid passage

Front suspension noisy

- Insufficient fluid in fork
- Loose fork fasteners

FRONT WHEEL

⚠ WARNING

A contaminated brake disc or pad reduces stopping power. Discard contaminated pads and clean a contaminated disc with a high quality brake degreasing agent.

REMOVAL

Remove the front brake disc cover bolts.

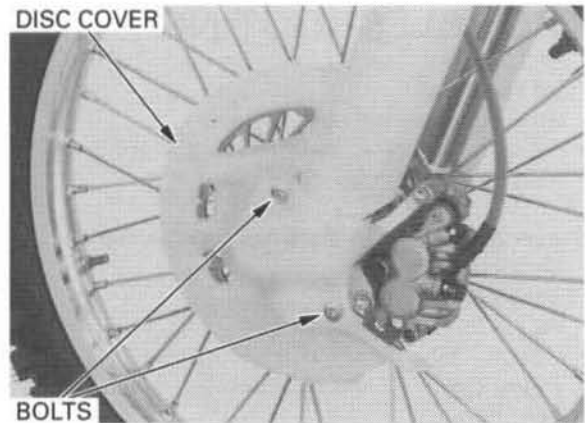

Support the motorcycle using the safety stand or hoist under the engine.

Remove the axle nut.

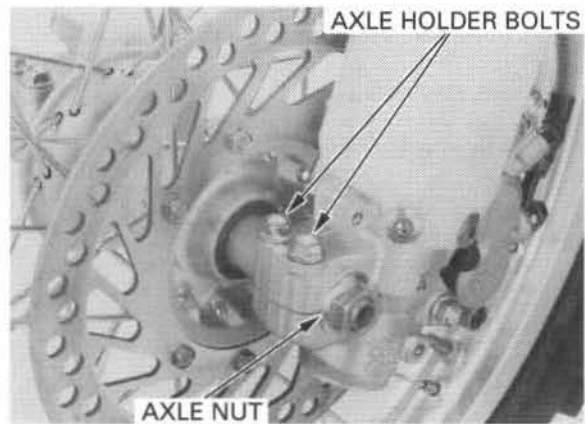

Loosen the axle holder bolts and pull out the axle.

Remove the front wheel assembly.

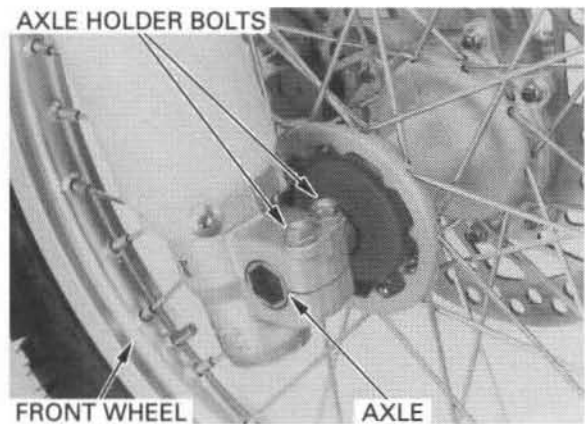

INSPECTION

AXLE

Set the axle in V-blocks and measure the runout. Turn the axle and measure the runout using a dial indicator. Actual runout is 1/2 the total indicator reading.

SERVICE LIMIT: 0.2 mm (0.008 in)

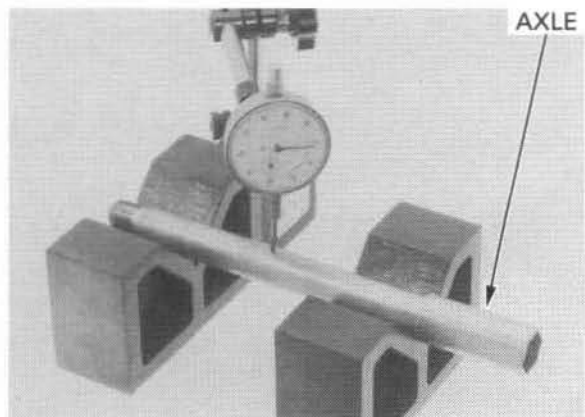

WHEEL BEARING

Turn the inner race of each bearing with your finger. The bearings should turn smoothly and quietly. Also check that the bearing outer race fits tightly in the hub.

Replace the bearing in pairs.

Remove and discard the bearings if the races do not turn smoothly, quietly, or if they fit loosely in the hub.

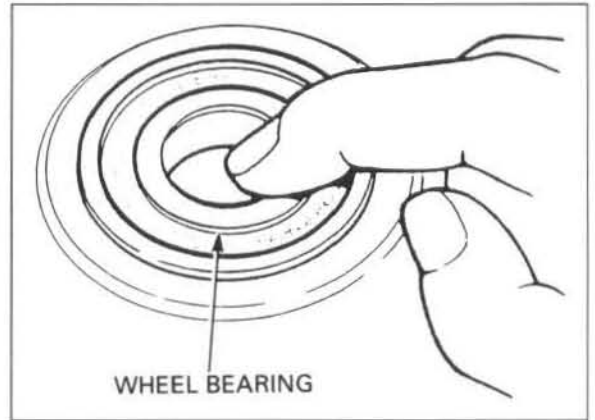

WHEEL RIM

Check the rim runout by placing the wheel on a turning stand. Then rotate the wheel by hand, and read the runout using a dial indicator. Actual runout is 1/2 the total indicator reading.

SERVICE LIMITS: Radial: 2.0 mm (0.08 in)
Axial: 2.0 mm (0.08 in)

Check the spokes and tighten any distance collar.

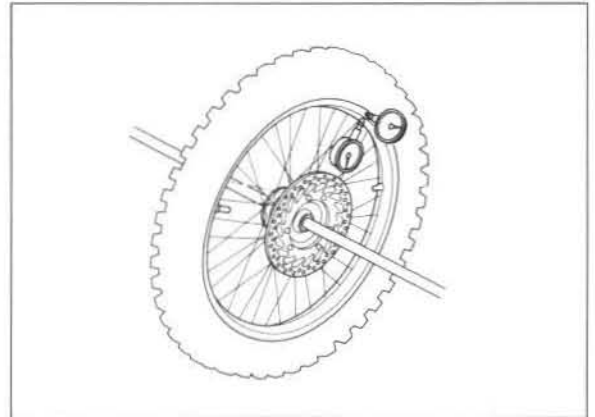

DISASSEMBLY

Remove the right side collar and dust seal.

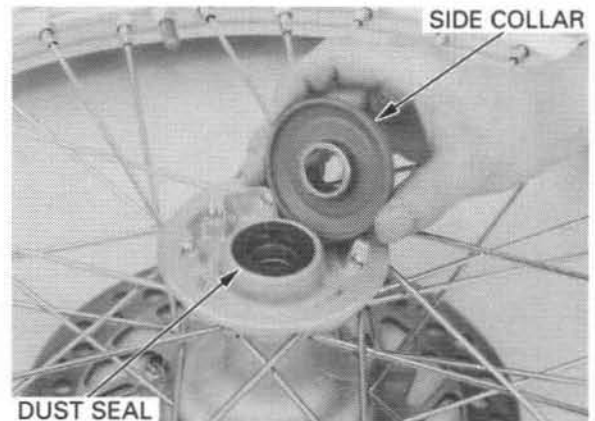

Remove the left side collar and dust seal.
Remove the brake disc bolts and nuts.
Remove the brake disc.

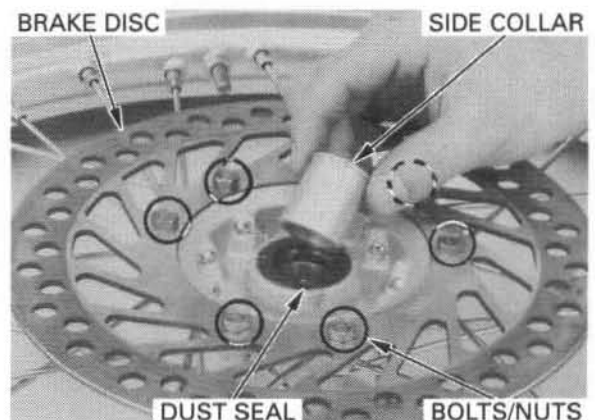

FRONT WHEEL/SUSPENSION/STEERING

Remove the wheel bearings and distance collar.

TOOLS:

Bearing remover head, 20 mm 07746 - 0050600

Bearing remover shaft 07746 - 0050100

NOTE:

- Never reinstall the old bearings; once the bearings have been removed, they must be replaced with new ones.
- Replace the bearing in pairs

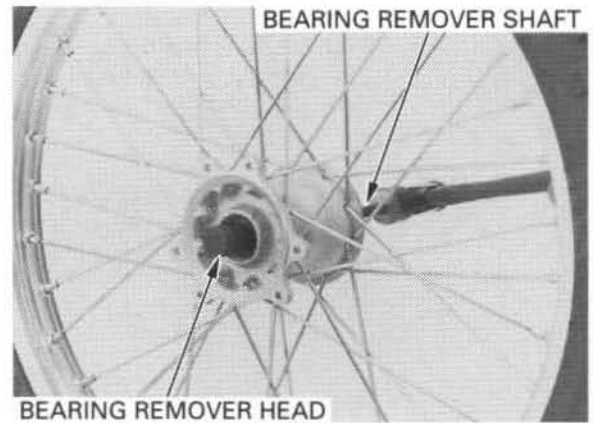

ASSEMBLY

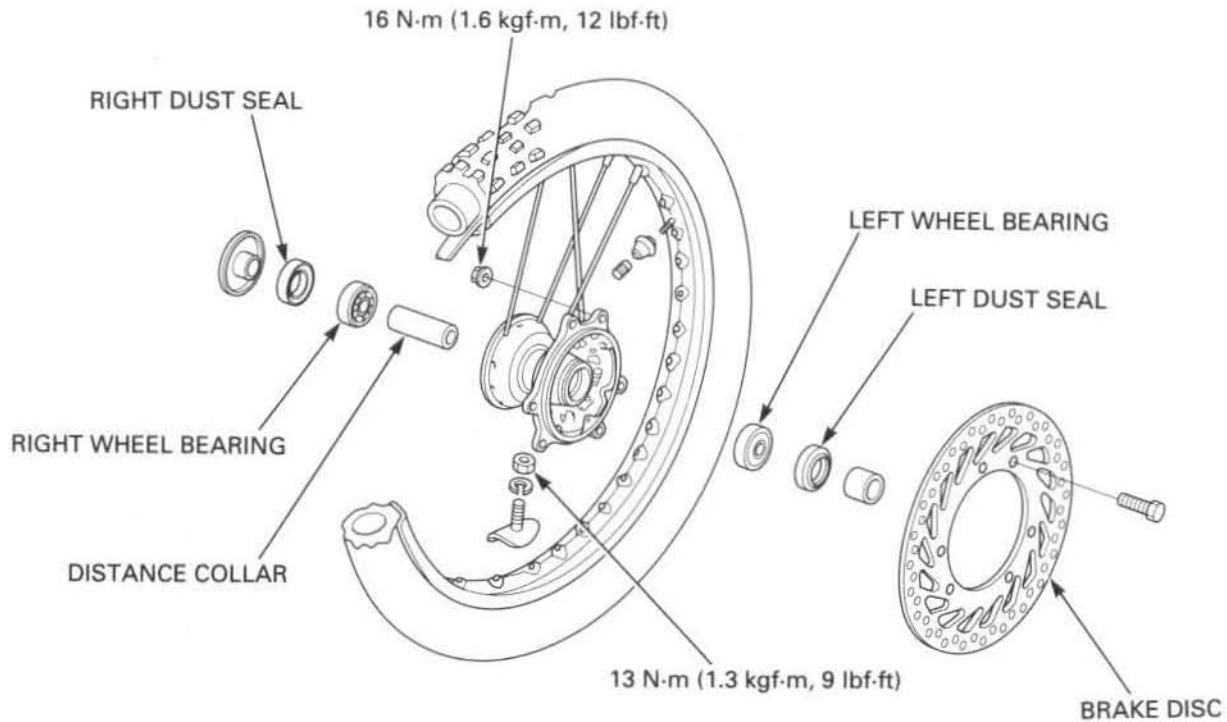

Place the rim on the work bench.

Place the hub with the disc side down and begin lacing with new spokes.

Adjust the hub position so that the distance from the hub left end surface to the side of rim is as shown.

STANDARD: 27.25 mm (1.073 in)

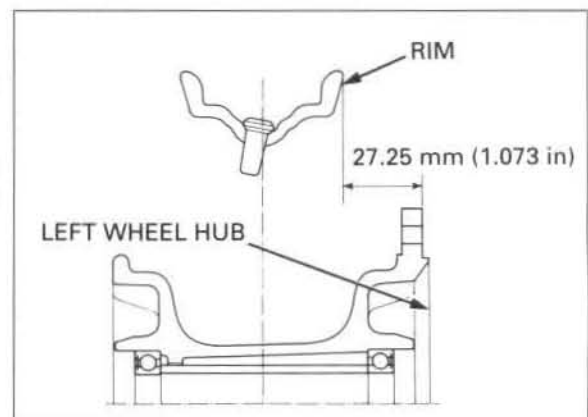

Torque the spokes in 2 or 3 progressive steps.

TOOL:

Spoke wrench, 5.8 x 6.1 mm 07701 – 0020300 or equivalent commercially available in U.S.A.

TORQUE: 4 N·m (0.4 kgf·m, 3.0 lbf·ft)

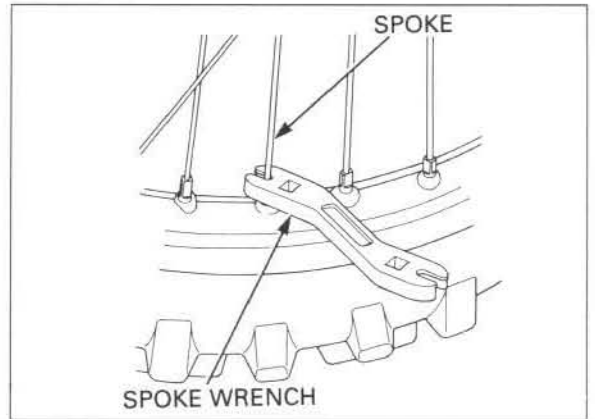

Install the rim lock, rim band, tube and tire.

Torque the rim lock to the specified torque.

TORQUE: 13 N·m (1.3 kgf·m, 9 lbf·ft)

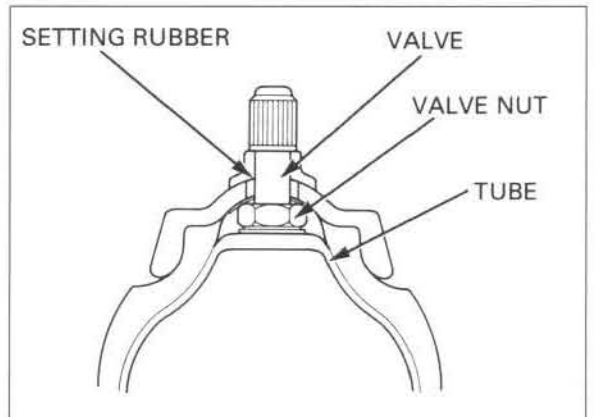

Pack all bearing cavities with grease.

Drive in the left wheel bearing into the hub using the special tools as shown.

TOOLS:

Driver	07749 – 0010000
Attachment, 37 x 40 mm	07746 – 0010200
Pilot, 20 mm	07746 – 0040500

Install the distance collar into place, then drive the right wheel bearing using the same special tools.

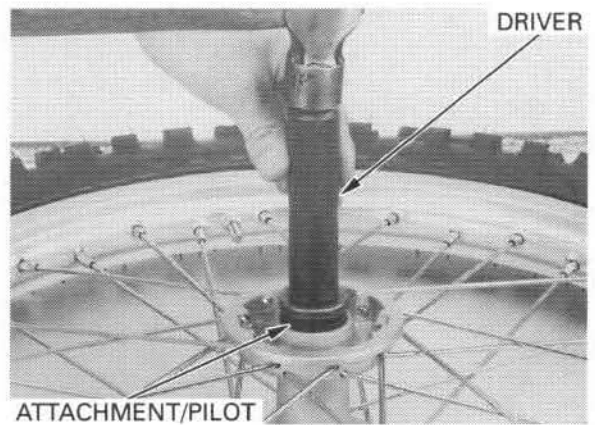

Pack the right dust seal lip with the grease and install the right dust seal.

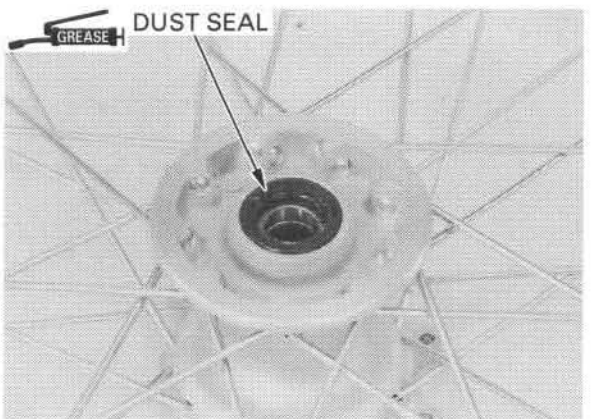

FRONT WHEEL/SUSPENSION/STEERING

Install the brake disc onto the wheel hub with the "DRIVE" mark facing out.

Clean and apply a locking agent to the brake disc bolt threads.

Install the brake disc bolts and nuts.
Tighten the nuts to the specified torque.

TORQUE: 16 N·m (1.6 kgf·m, 12 lbf·ft)

Pack the left dust seal lip with the grease and install the left dust seal.

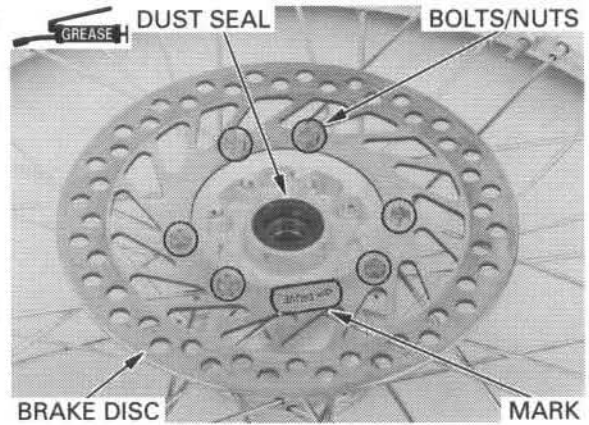

Check the right and left wheel collars for wear or damage.

Install the right and left wheel collars to the wheel as shown.

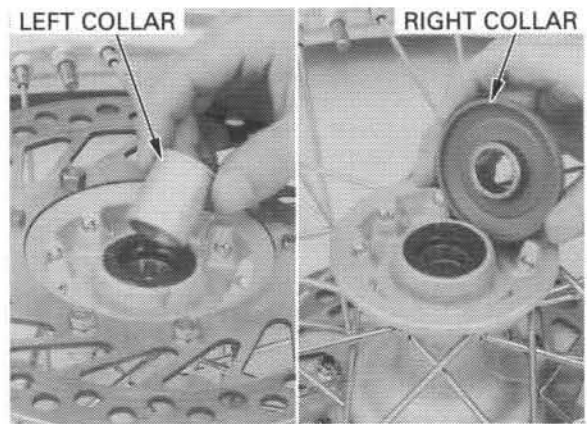

INSTALLATION

Clean the clamping surface of the axle shaft and axle holders.

Install the front wheel between the fork legs.

Fit the caliper over the disc, taking care not to damage the brake pads.

Apply a thin layer of grease to the axle and insert the axle from the right side.

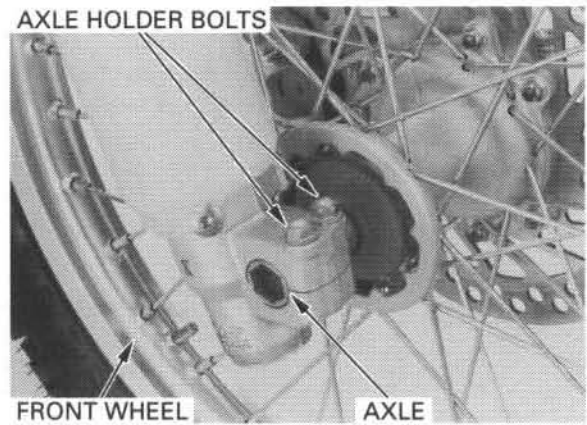

Install and tighten the axle nut to the specified torque.

TORQUE: 88 N·m (9.0 kgf·m, 65 lbf·ft)

Tighten the left axle holder bolts to the specified torque.

TORQUE: 20 N·m (2.0 kgf·m, 14 lbf·ft)

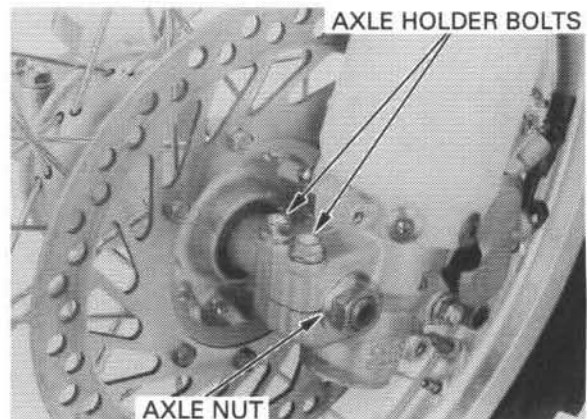

With the front brake applied, pump the front suspension up and down several times to seat the axle and check front brake operation.

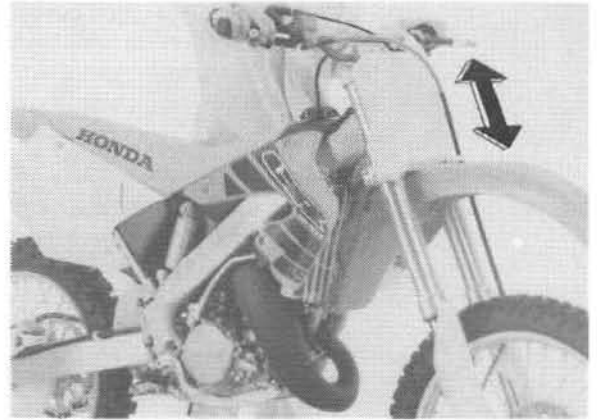

Be sure the fork legs are parallel, then tighten the right axle holder bolts to the specified torque.

TORQUE: 20 N·m (2.0 kgf·m, 14 lbf·ft)

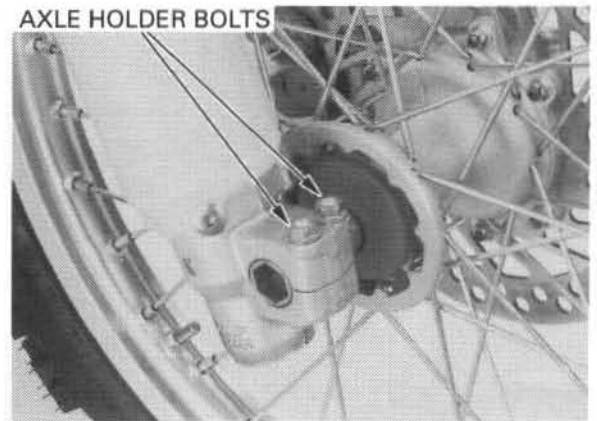

Install the front brake disc cover. Install and tighten the front brake disc cover bolts to the specified torque.

TORQUE: 13 N·m (1.3 kgf·m, 9 lbf·ft)

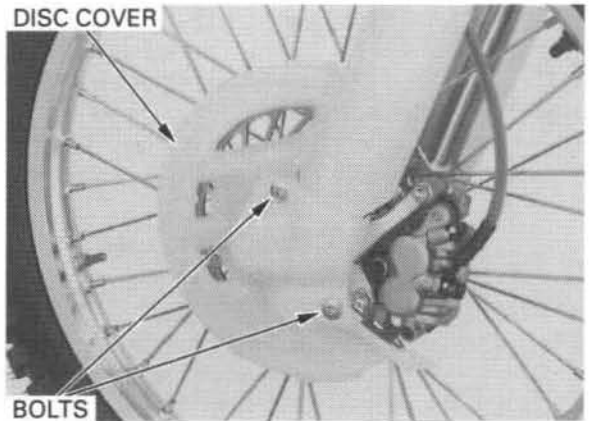

FORK

REMOVAL

Remove the front wheel (page 11-4).
Remove the brake caliper (page 13-14).

CAUTION:

Do not suspend the brake caliper from the brake hose. Do not twist the brake hose.

NOTE:

Do not operate the brake lever after removing the caliper and front wheel. To do so will cause difficulty in fitting the brake disc between the brake pad.

Remove the bolts and fork protector.

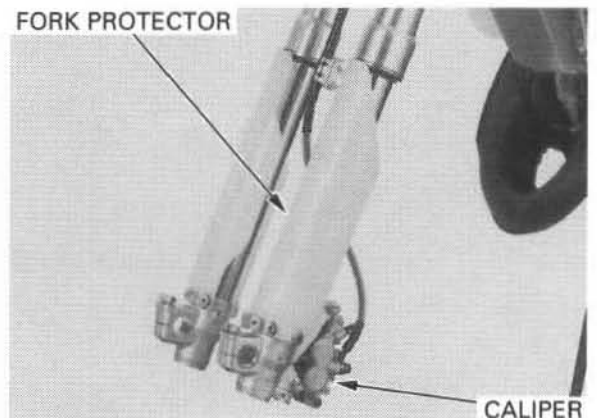

FRONT WHEEL/SUSPENSION/STEERING

Loosen the fork top pinch bolts.
When the fork is ready to be disassembled, remove the handlebar and loosen the fork cap, but do not remove it.

CAUTION:

- *Do not use a crescent or adjustable wrench to loosen the fork cap; they could be damaged.*
- *When disassembling the fork leg, record the number of clicks to hardest position then turn the rebound adjuster and compression adjuster counterclockwise to the softest position to prevent damage the needle.*

COMPRESSION ADJUSTER

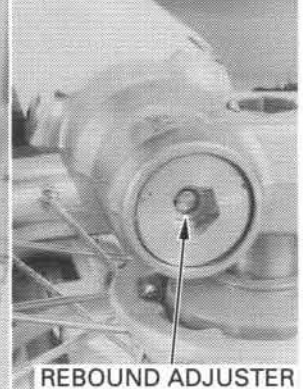
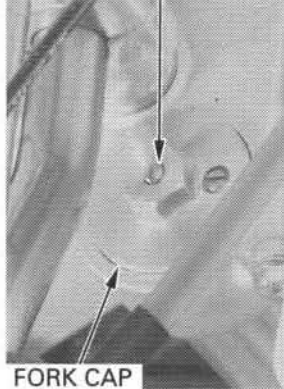

Loosen the fork bottom pinch bolts and pull the fork leg down and out.

TOP PINCH BOLTS

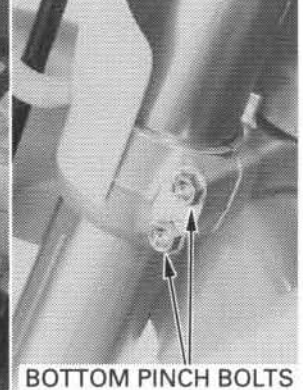
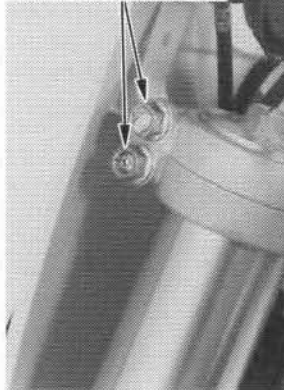

DISASSEMBLY

Clean the fork assembly, especially the sliding surface of the fork slider and bottom of the slider around the center bolt before disassembling the fork.

CAUTION:

Be careful not to scratch the slider and not to damage the dust seal.

Hold the outer tube, remove the fork cap from the outer tube and slide the outer tube down to the dust seal on the axle holder.

FORK CAP

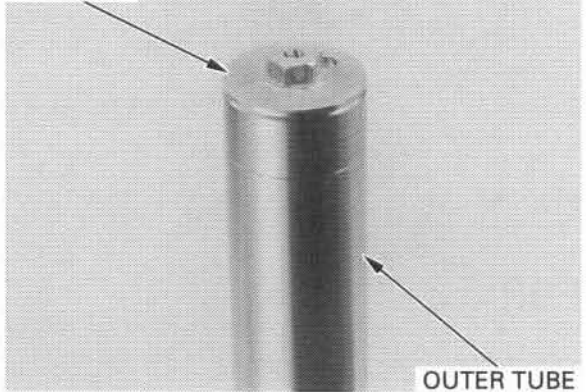

DUST SEAL

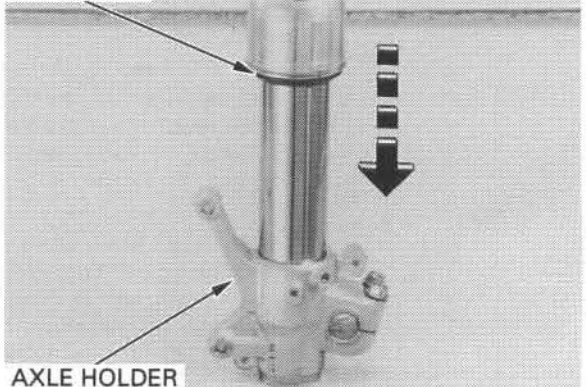

Hold the lock nut and remove the fork cap from the damper rod.

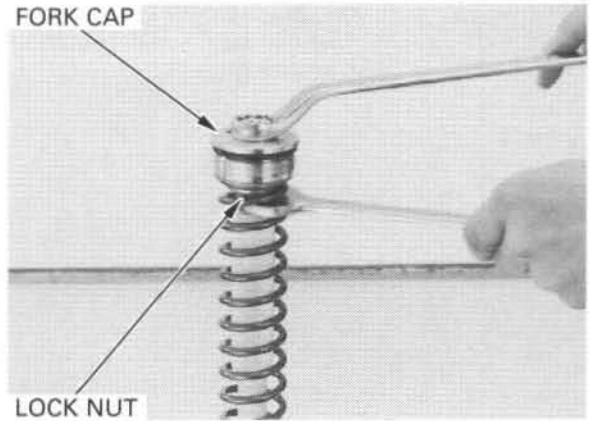

Remove the spring seat and fork spring.

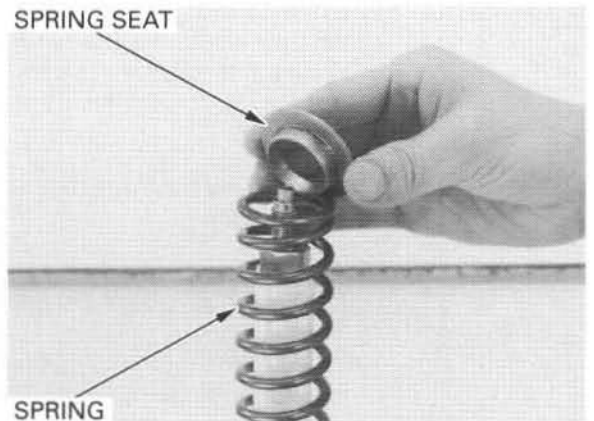

CAUTION:

When the fork cap removed from the damper rod, the slider can move up and down freely on the outer tube. Always hold both the outer tube and slider with your hands after removing the fork cap, or the guide and slider bushings might be damaged.

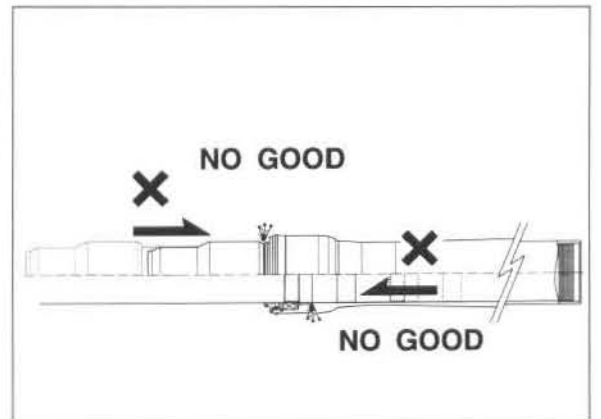

Remove the distance collar, lock nut, spring guide and O-ring.

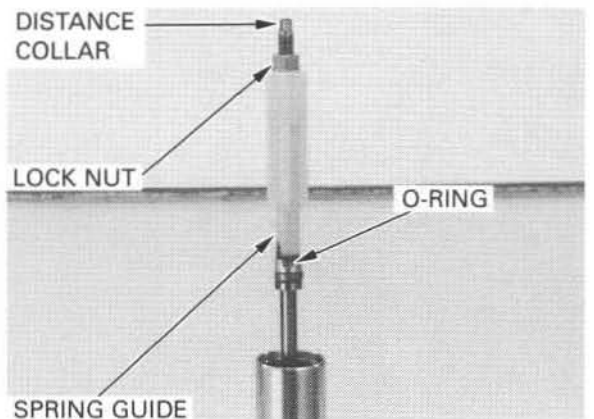

Remove the dust seal and stop ring.

CAUTION:

Be careful not to scratch the slider.

Check that the slider moves smoothly in the outer tube.

If it does not, check the slider for bend or damage, and the bushings for wear or damage.

If the slider and bushings are normal, check the outer tube.

In quick successive motions, pull the slider out of the outer tube.

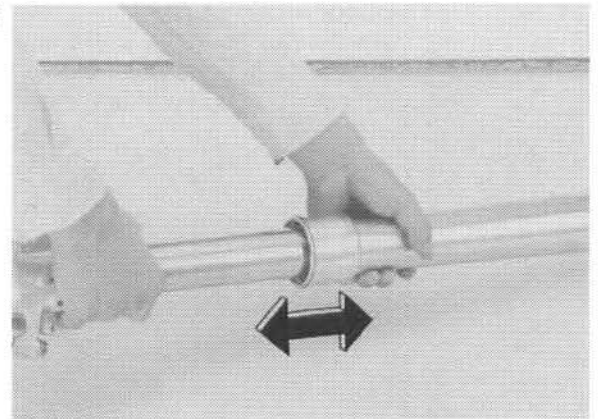
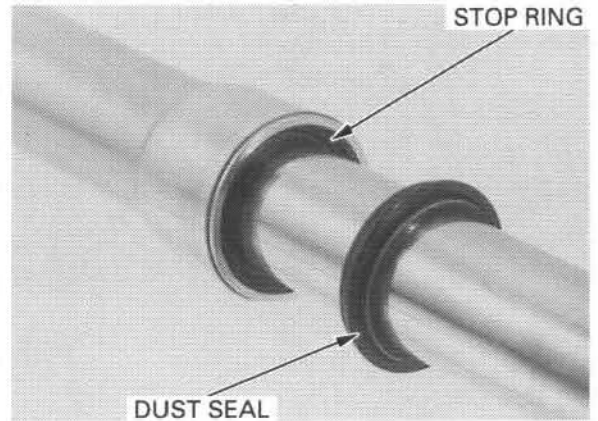

Carefully remove the slider bushing by prying the slot with a screwdriver until the bushing can be pulled off by hand.

CAUTION:

Do not damage the slider bushing, especially the sliding surface. To prevent loss of tension, do not open the bushing more than necessary.

Remove the following from the slider.

- Guide bushing
- Back-up ring
- Oil seal
- Stop ring
- Dust seal

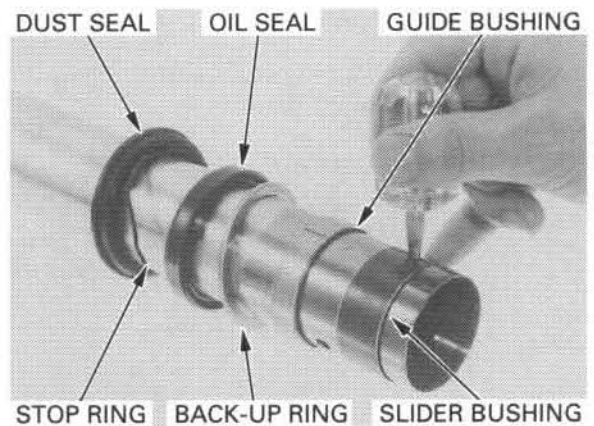

INSPECTION

FORK CAP

Check that the O-ring on the fork cap is in good condition.

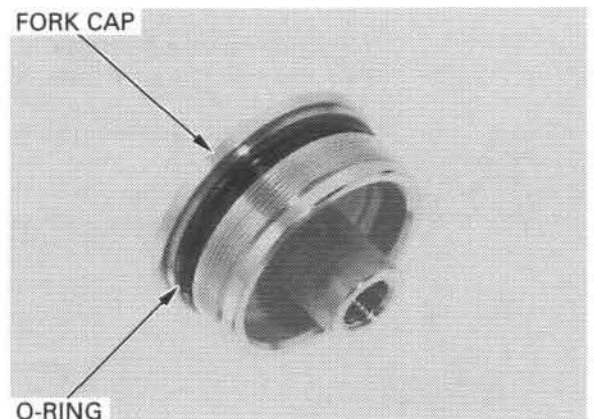

FRONT WHEEL/SUSPENSION/STEERING

FORK CENTER BOLT

Check the fork center bolt for damage.
Replace the O-rings and sealing washer with a new one.

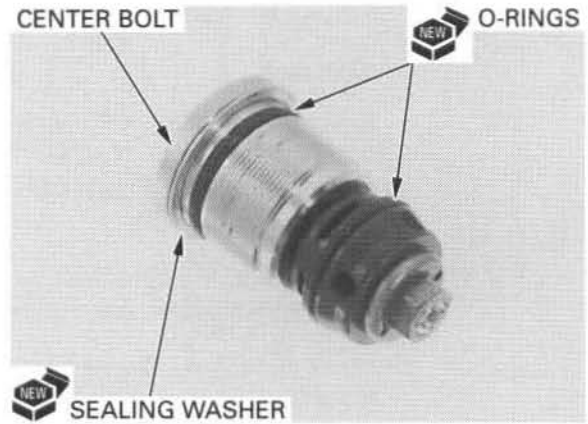

SLIDER/OUTER TUBE

Check the slider for score marks, scratches and excessive or abnormal wear.
Check the outer tube for damage or deformation.

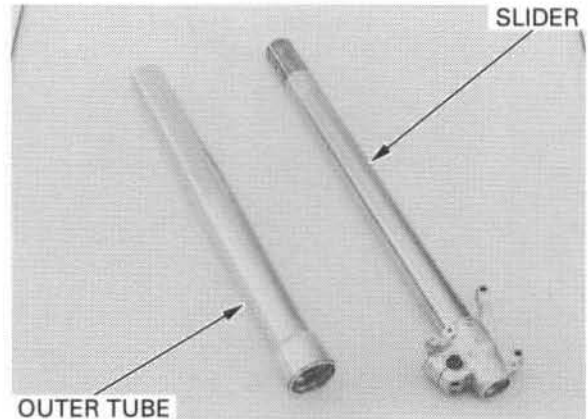

Inspect the wear ring for wear or damage.

Install the wear ring securely in the protector guide groove

Replace the wear ring, if it is within 1.5 mm (0.05 in) of the protector guide.

CAUTION:

The outer tube can move up and down freely on the slider. Always hold the slider and fork tube with your hands, or the guide and slider bushings might be damaged.

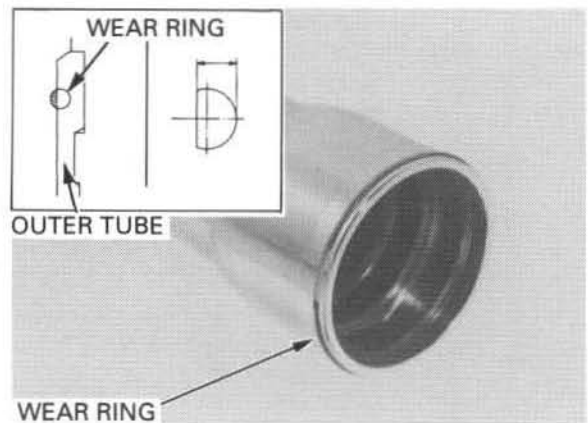

Set the slider in V-blocks and measure the fork tube runout by rotating it with a dial indicator.
Actual runout is 1/2 the total indicator reading.

SERVICE LIMIT: 0.20 mm (0.008 in)

Do not reuse the slider if it bent.

Replace if the service limit is exceeded, or there are scratches or nicks that will allow fork oil to leak past the seals.

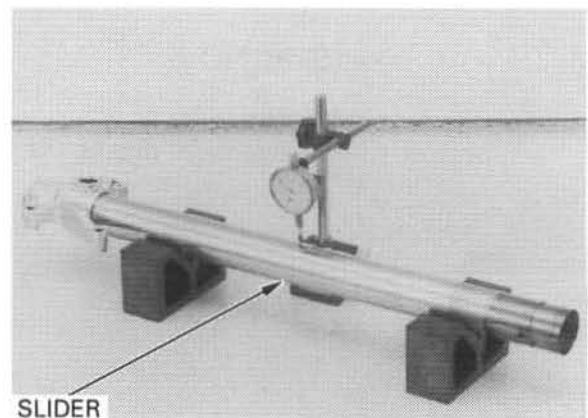

FORK SPRING

Measure the fork spring free length by placing on a flat surface.

SERVICE LIMIT: 467 mm (18.4 in)

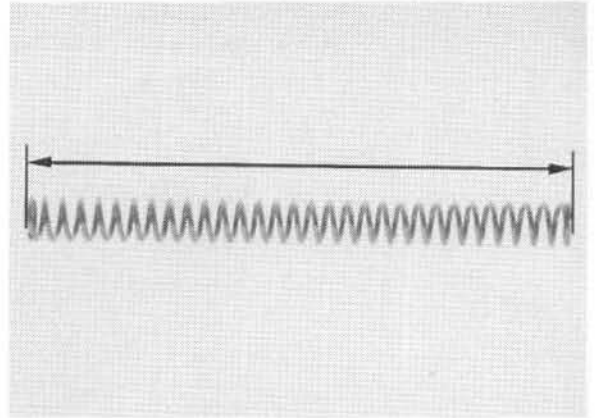

SPRING GUIDE

Check the spring guide for wear or damage.

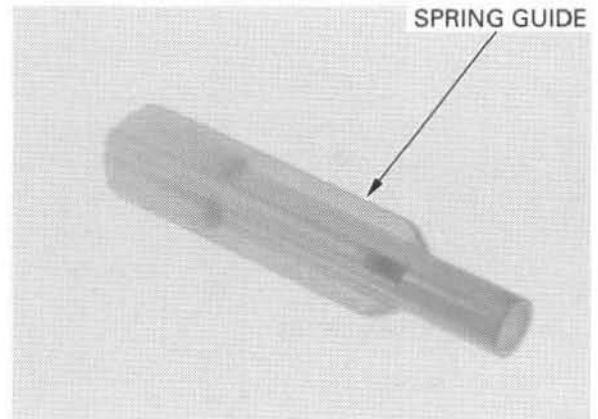

BUSHING/BACK-UP RING

Check the bushings for excessive wear or scratches. If copper appears on the entire surface, replace the bushings.

Replace the back-up ring if there is distortion at the points shown.

Remove any metal powder from the slider and guide bushings with a nylon brush and fork oil.

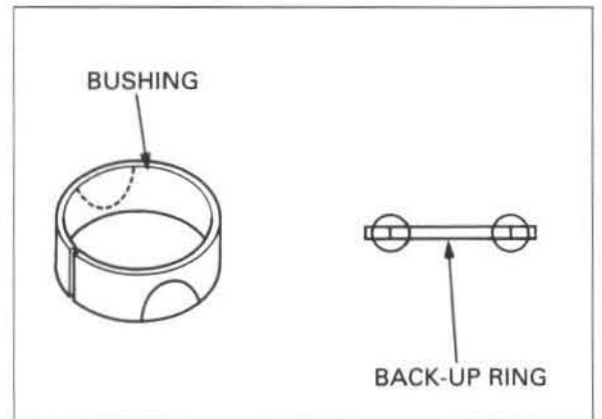

FORK DAMPER

Check the damper rod of the damper for bend, wear or damage.

Check the bladder and stop rings for damage.

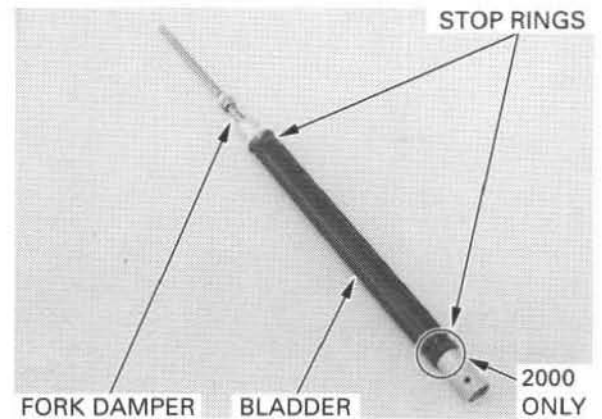

FRONT WHEEL/SUSPENSION/STEERING

DISTANCE COLLAR

Check the distance collar for bend, wear or damage.

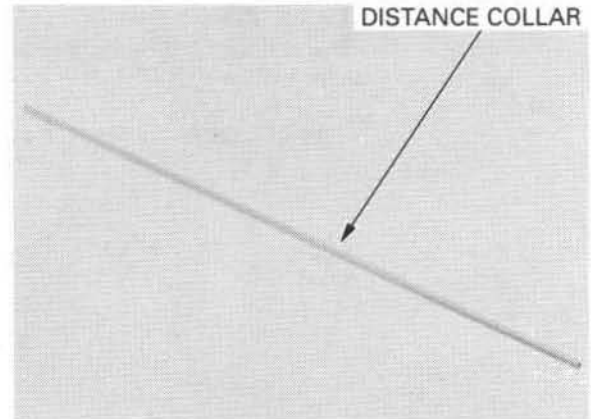

ASSEMBLY

NOTE:

Clean the disassembled parts thoroughly with nonflammable or high flash point solvent before assembly.

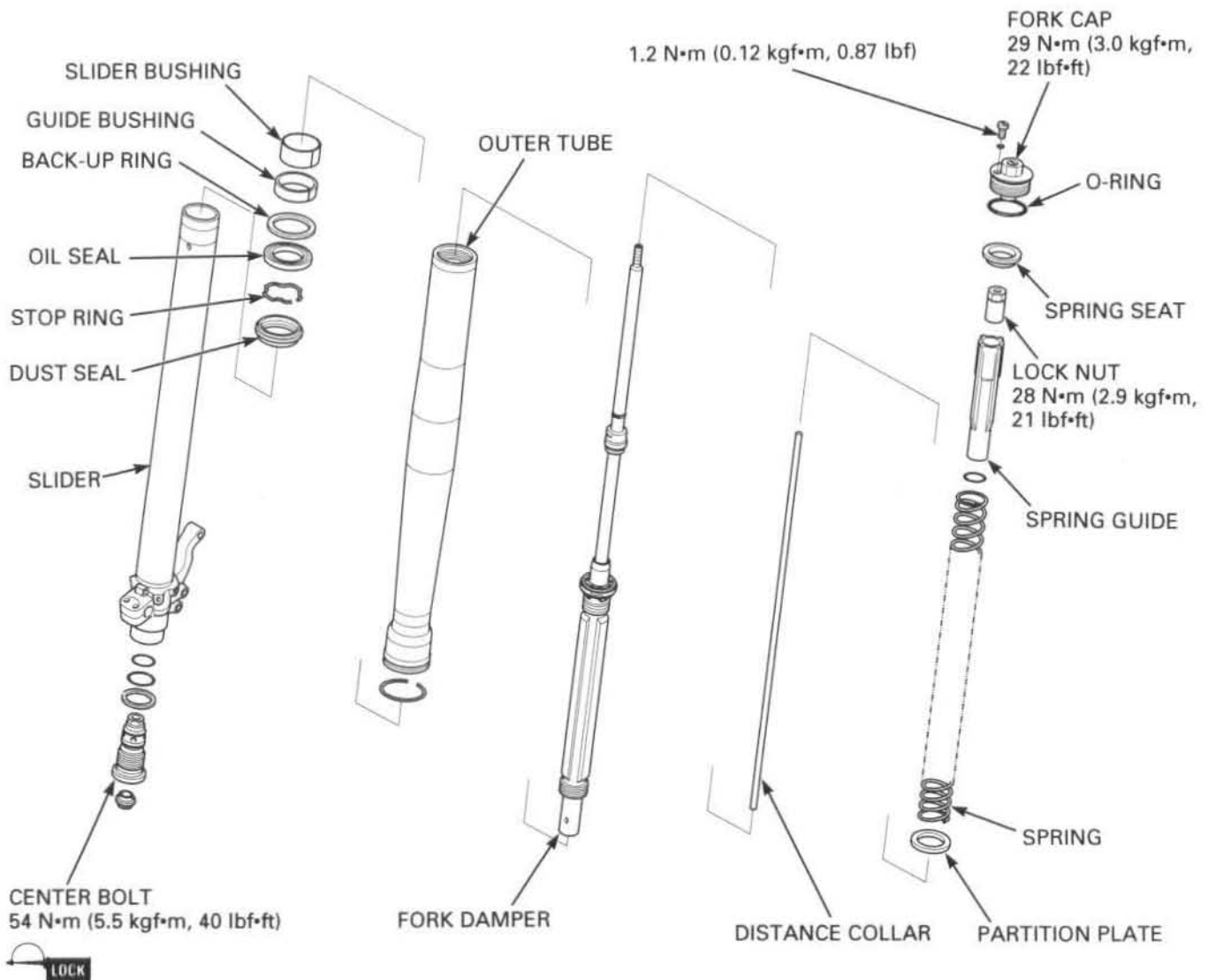

Wrap the end of the slider with tape.
Coat the new oil seal lips with fork oil.

Install the following to the slider:

- Dust seal
- Stop ring
- Oil seal

NOTE:

Install the oil seal with its marked side facing the dust seal.

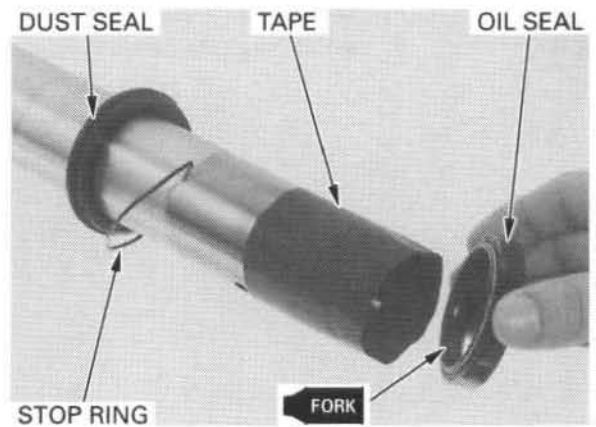

Remove the tape from the end of slider.

Install the following on to the slider.

- Back-up ring
- Guide bushing
- Slider bushing

NOTE:

Remove the burrs from the bushing taking care not to peel of its coating.

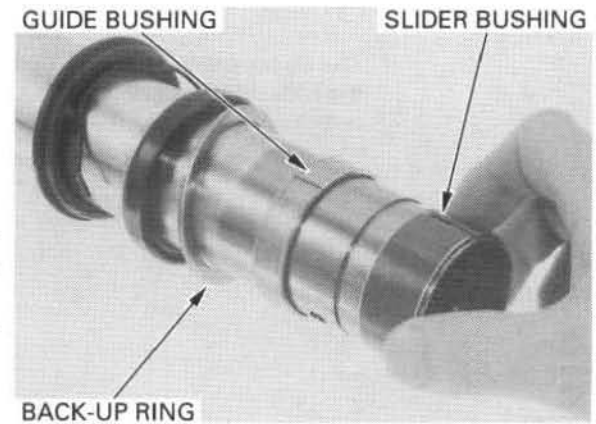

Coat the slider and guide bushings with the recommended fork oil and install the slider into the outer tube.

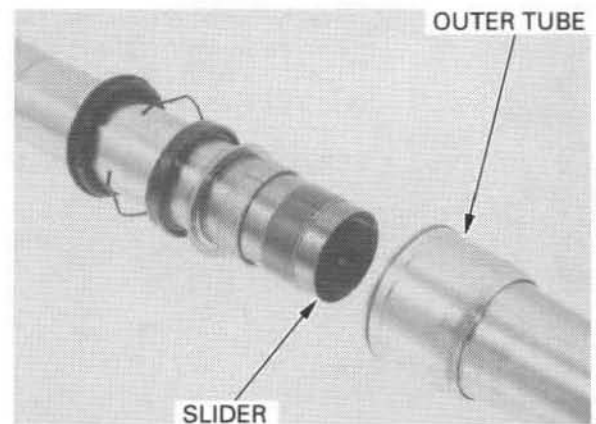

Drive in the guide bushing together with the back-up ring and oil seal into the outer tube, using the special tool.

TOOL:

Fork seal driver, 46 mm

07TMD - MAC0100 or
07TMD - MAC010A
(U.S.A. only)

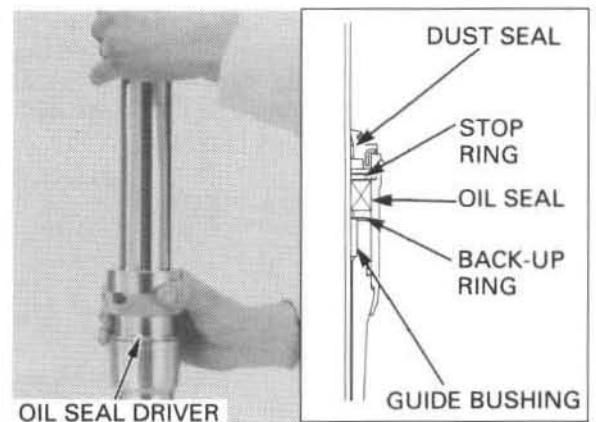

FRONT WHEEL/SUSPENSION/STEERING

Install the stop ring to the groove of the slider.
Install the dust seal.

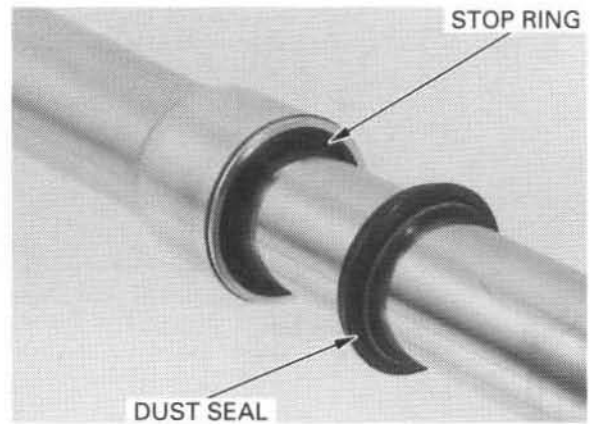

CAUTION:

The outer tube can move up and down freely on the slider. Always grip both the outer tube and slider with your hands, or the guide, bushings and dust seal might be damaged.

To avoid damaging the dust seal, lower the outer tube gently onto the axle holder.

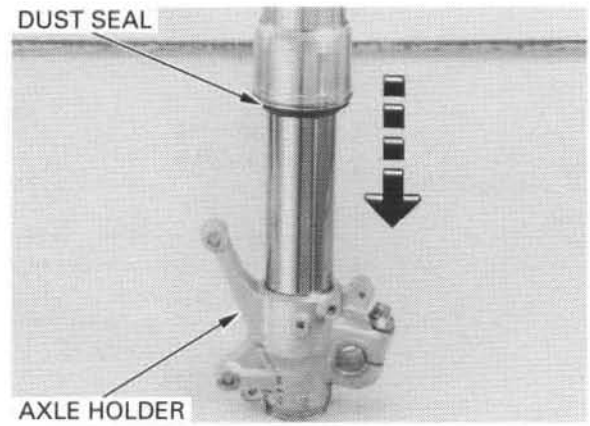

If you removed the bladder from the fork damper, measure the full length of bladder.
If the full length is under the service limit, replace with a new one.

SERVICE LIMIT: 387 mm (15.2 in)

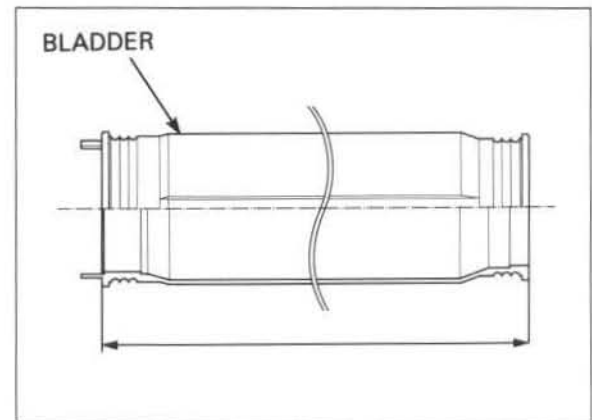

Apply fork oil to the bladder lips.
Install the bladder aligning the lips on the bladder with the grooves on the fork damper.
Check the bladder is not twisted.
Install the new six stop rings securely.

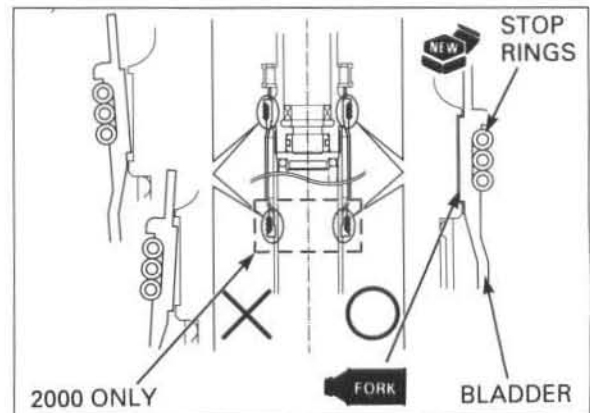

Install the fork damper into the fork tube.

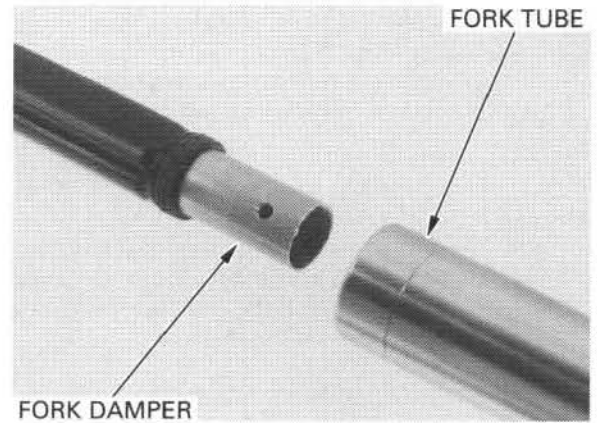

Coat the O-ring of the center bolt with the recommended fork oil.

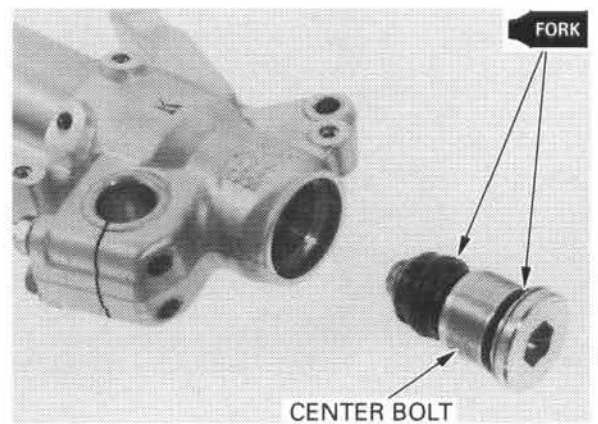

Hold the axle holder in a vise with a piece of wood or soft jaws.

CAUTION:

Do not overtighten the axle holder.

Apply a locking agent to the center bolt threads.

Install the center bolt with a new sealing washer.

Scribe the index line to the fork rod holder handle (page 11-12).

Attach the fork rod holder assembly to the center bolt aligning it index line to the fork outer tube end.

Tighten the bolt using the special tools as shown.

TOOLS:

- Fork rod holder handle 07TMB – 001010A
- Fork rod holder attachment, 32 mm 07YMB – KZ40100

TORQUE: 54 N•m (5.5 kgf•m, 40 lbf•ft)

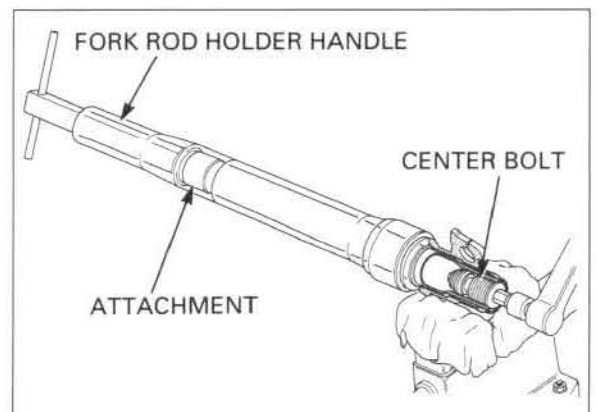
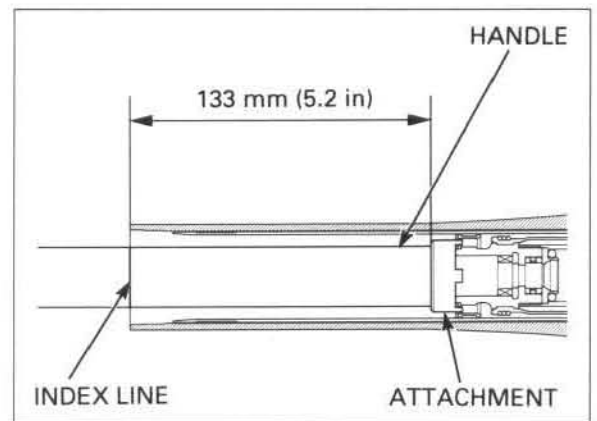

FRONT WHEEL/SUSPENSION/STEERING

Install the lock nut with the threaded side facing up. Install the distance collar into the fork damper. Install the spring guide, new O-ring and lock nut to the fork damper and turn the lock nut by hand until it bottoms on the damper rod.

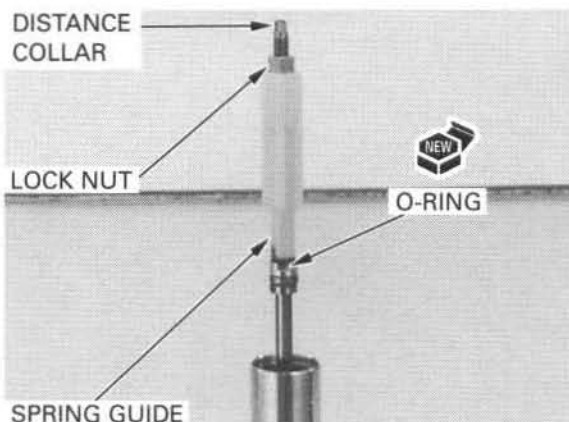

Make sure that the partition plate is removed. Pour the recommended fork oil into the damper rod until the oil flows out the damper rod end. Pour half the amount of the recommended fork oil into the fork leg.

RECOMMENDED OIL:

Pro Honda HP Fork Oil 5W or equivalent

STANDARD OIL LEVEL:

2000: 60 mm (2.4 in)
2001: 59 mm (2.3 in)
After 2001: 98 mm (3.9 in)

STANDARD OIL CAPACITY:

2000: 518 cm³ (17.5 US oz, 18.2 Imp oz)
2001: 502 cm³ (17.0 US oz, 17.7 Imp oz)
After 2001: 475 cm³ (16.1 US oz, 16.7 Imp oz)

Bleed the air as follows:

1. Extend the fork. Cover the top of the outer tube with your hand and compress the fork slowly.
2. With the damper rod pushed fully in, pour the recommended fork oil into the rod until a little flows out of the end rod.
3. Pump the outer tube and rod slowly eight or ten times.
4. Add additional oil up to the specified capacity and repeat step 3.

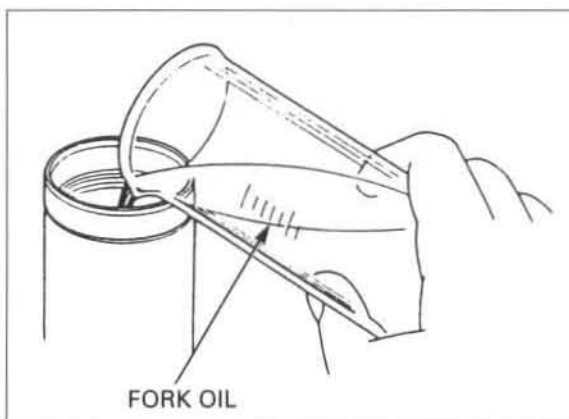

NOTE:

- Be sure the oil level is the same in both fork legs.
- Support the fork leg vertically and the fork is compressed fully whenever measuring the oil level.

2000:

Maximum oil level capacity	35 mm (1.4 in) 548 cm ³ (18.5 US oz, 19.3 Imp oz)	Slightly stiffer as the fork nears full compression.
Minimum oil level capacity	88 mm (3.5 in) 484 cm ³ (16.4 US oz, 17.0 Imp oz)	Slightly softer as the fork nears full compression.

2001:

Maximum oil level capacity	30 mm (1.2 in) 537 cm ³ (18.2 US oz, 18.9 Imp oz)	Slightly stiffer as the fork nears full compression.
Minimum oil level capacity	83 mm (3.3 in) 473 cm ³ (16.0 US oz, 16.7 Imp oz)	Slightly softer as the fork nears full compression.

After 2001:

Maximum oil level capacity	37 mm (1.5 in) 548 cm ³ (18.5 US oz, 19.3 Imp oz)	Slightly stiffer as the fork nears full compression.
Minimum oil level capacity	123 mm (4.8 in) 445 cm ³ (15.0 US oz, 15.7 Imp oz)	Slightly softer as the fork nears full compression.

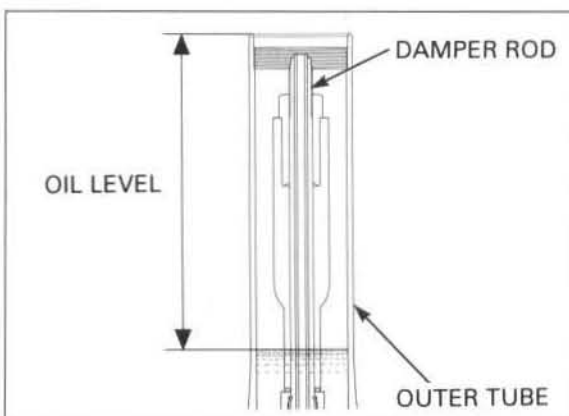
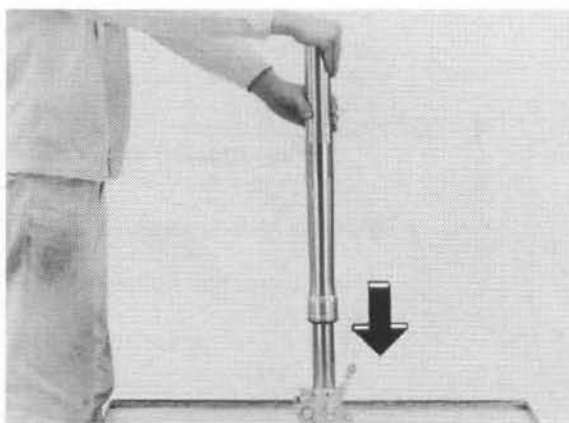

Remove the lock nut and spring guide.
Install the partition plate.
Reinstall the spring guide and lock nut

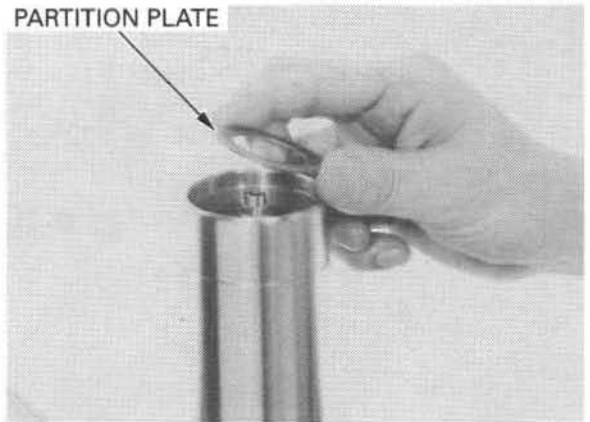

For details regarding the oil level adjustment, refer to the Owner's Manual.

Attach a 600 mm (2 feet) length of mechanic's wire to the lock nut on the damper rod.

Wipe off any excessive oil from fork spring, then install it over the wire and into the slider with tapered side facing up.

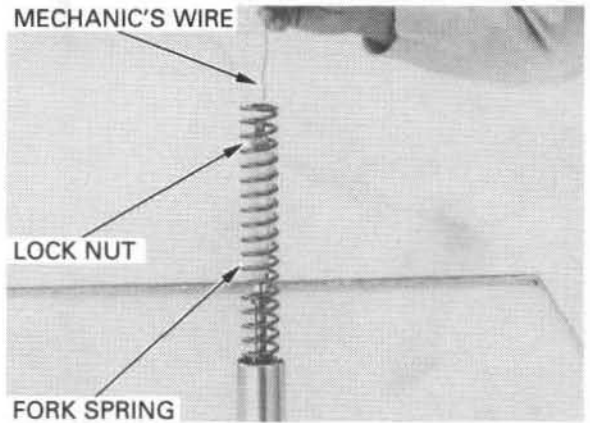

Pull the mechanic's wire up and hold the damper rod at the damper rod.
Remove the mechanic's wire from the damper rod.
Turn the lock nut by hand until it bottoms on the damper rod.

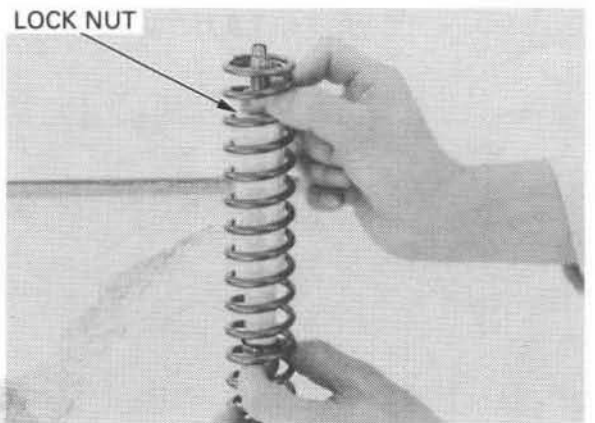

Install the spring seat onto the fork spring.

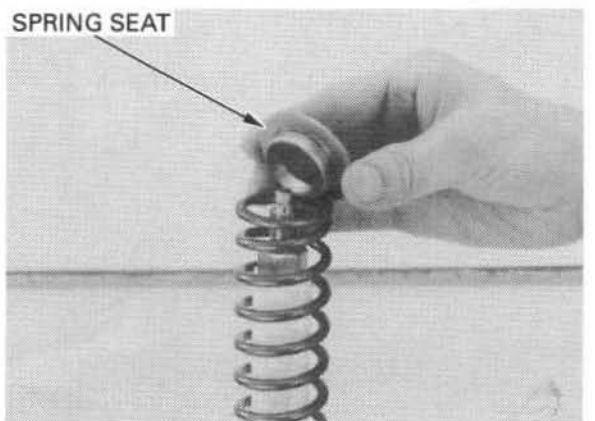

FRONT WHEEL/SUSPENSION/STEERING

Check that the fork cap O-ring is in good condition.

Screw the fork cap on the damper rod.

Hold the lock nut and tighten the fork cap to the specified torque.

TORQUE: 28 N·m (2.9 kgf·m, 21 lbf·ft)

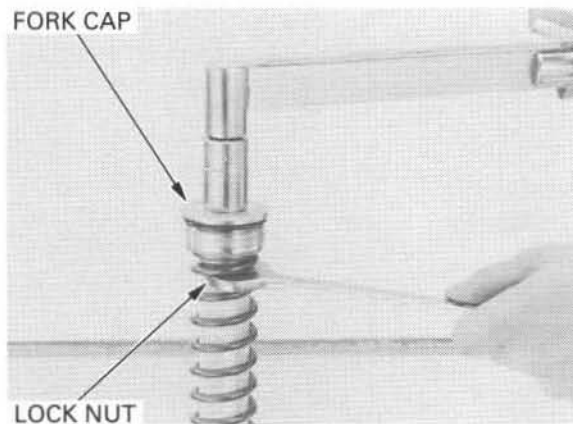

Temporarily install the fork cap in the outer tube.

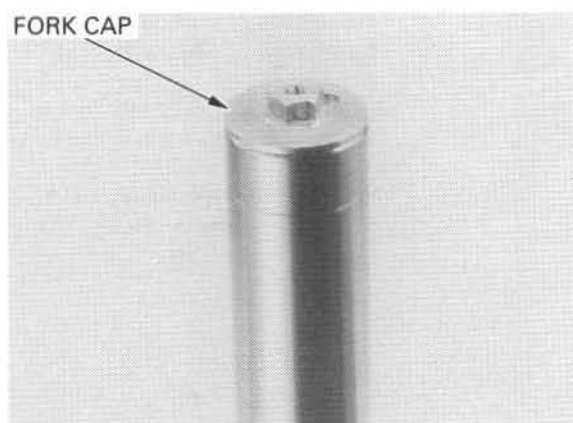

INSTALLATION

Install the fork leg.

Tighten the bottom bridge pinch bolts to the specified torque.

TORQUE: 20 N·m (2.0 kgf·m, 14 lbf·ft)

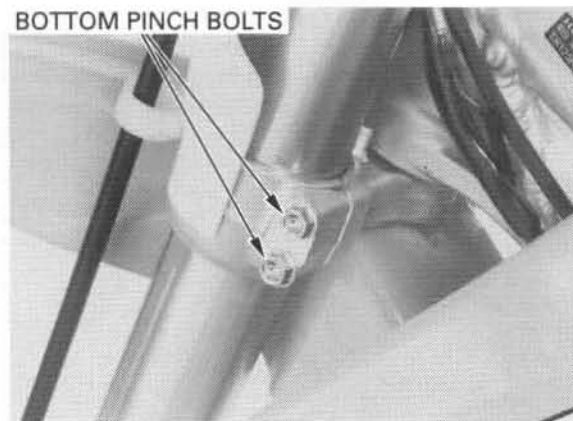

Tighten the fork cap to the specified torque.

TORQUE: 29 N·m (3.0 kgf·m, 22 lbf·ft)

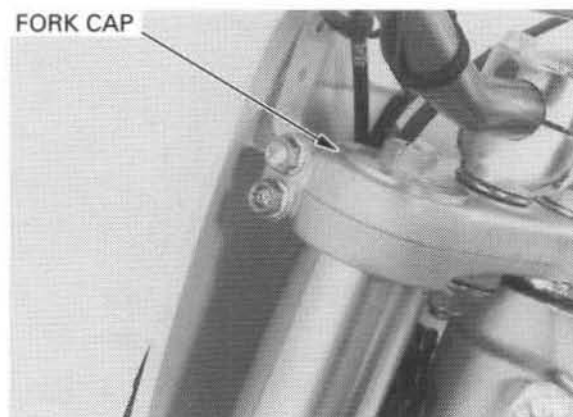

STANDARD POSITION

Loosen the bottom pinch bolts.
For ease of releasing the air pressure after the forks are installed, position the fork outer tubes so that the pressure release screws are in front of the rebound adjusters.

2000

Align the top surface of the top bridge with the top surface of the outer tube.

After 2000

Align the top surface of the top bridge with the index line of the outer tube.

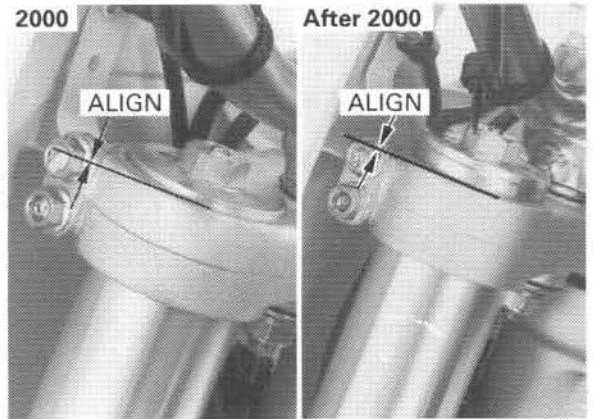

Tighten the bottom bridge pinch bolts to the specified torque.

TORQUE: 20 N·m (2.0 kgf·m, 14 lbf·ft)

Tighten the top bridge pinch bolts to the specified torque.

TORQUE: 22 N·m (2.2 kgf·m, 16 lbf·ft)

CAUTION:

Overtightening the pinch bolts can deform the outer tubes. A deformed outer tube must be replaced.

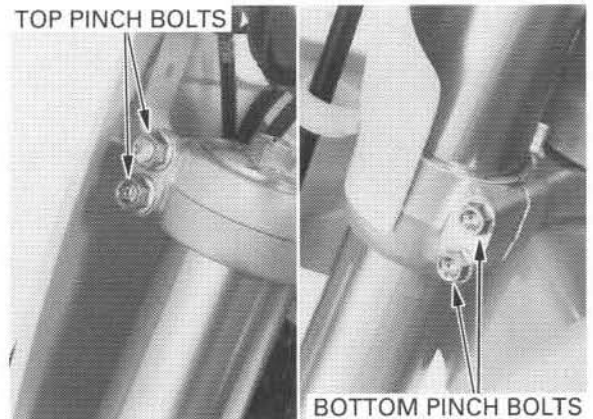

Turn the wear ring with the end gap facing rearward.

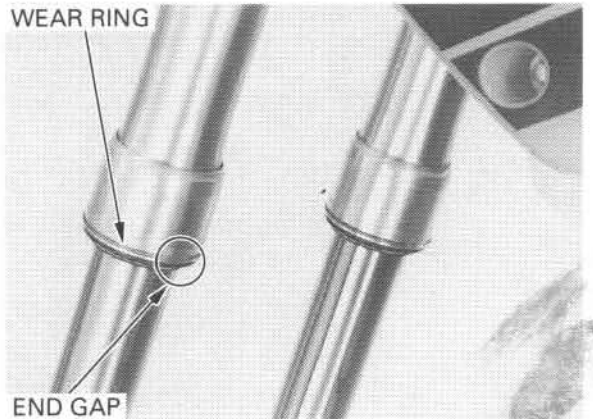

Tighten the brake hose guide bolts to the specified torque.

TORQUE: 5 N·m (0.5 kgf·m, 3.6 lbf·ft)

Clean and apply a locking agent to the fork protector mounting bolt threads.
Install the fork protector and tighten the mounting bolts to the specified torque.

TORQUE: 7 N·m (0.7 kgf·m, 5.1 lbf·ft)

Clean and apply a locking agent to the front brake caliper mounting bolt threads.
Install the front brake caliper and tighten the mounting bolts to the specified torque.

TORQUE: 30 N·m (3.1 kgf·m, 22 lbf·ft)

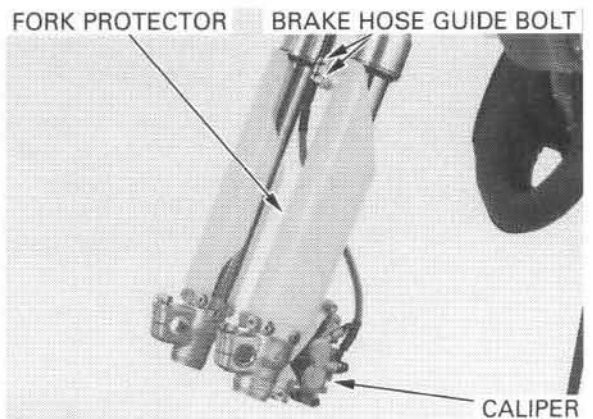

FRONT WHEEL/SUSPENSION/STEERING

Return rebound adjuster and compression adjuster to its original position as noted during removal.

Install the front wheel (page 11-8).

REBOUND ADJUSTER



COMPRESSION ADJUSTER

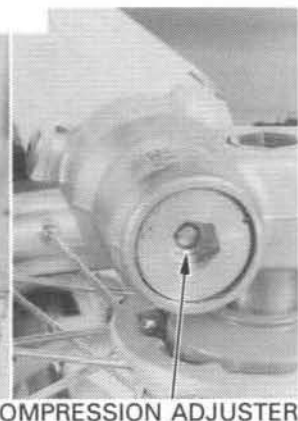

HANDLEBAR

REMOVAL

Disconnect the engine stop button connectors.

Unhook the holding tab of the number plate (page 2-3).

CONNECTORS

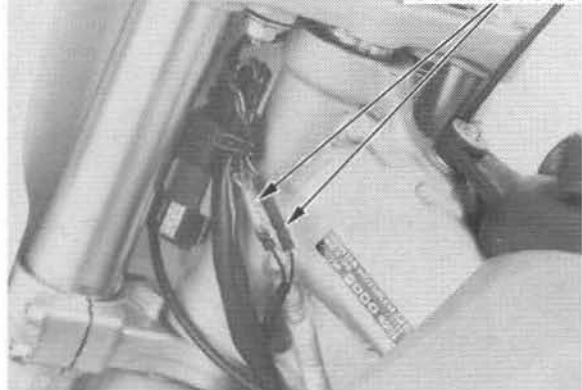

Remove the wire bands securing the engine stop button wire and remove the engine stop button.

Disconnect the clutch cable and remove the clutch lever bracket.

CLUTCH LEVER BRACKET

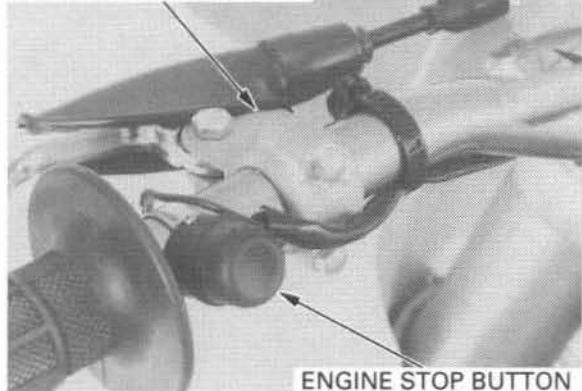

ENGINE STOP BUTTON

Remove the front brake master cylinder, with its holder, keeping it upright to prevent air from entering the hydraulic system.

CAUTION:

Do not disconnect the hydraulic line.

MASTER CYLINDER

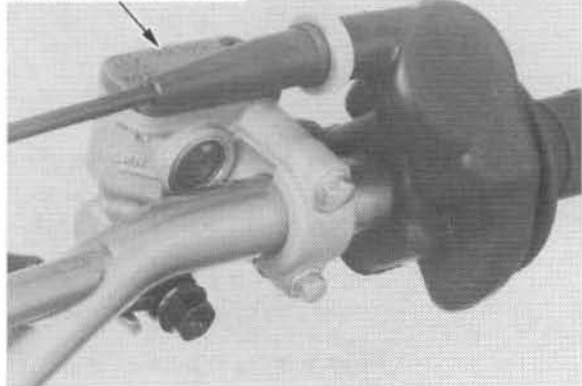

If you will not disassemble the throttle housing, remove the throttle housing as an assembly as follows.

Loosen the throttle housing bolts, turn the handlebar to the left fully, then remove the throttle housing.

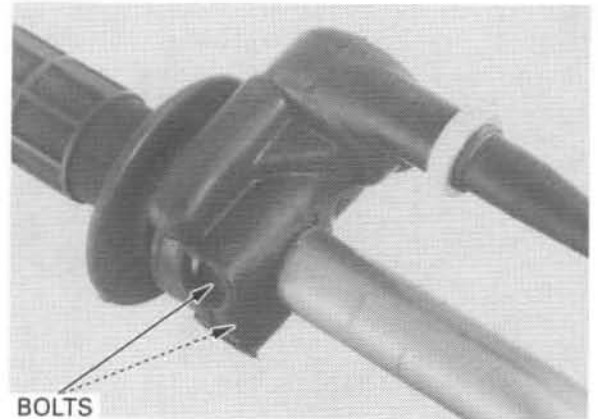

If you will disassemble the throttle housing, remove the throttle housing dust cover.

Remove the throttle housing cover by removing the screws. Slide the rubber protector off the throttle cable and loosen the lock nut and adjuster.

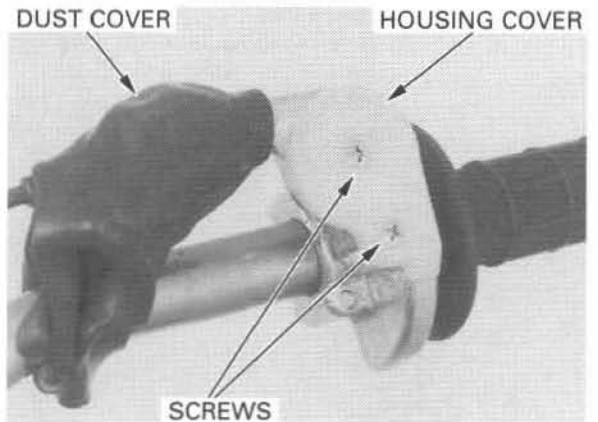

Remove the throttle cable roller and collar.

Disconnect the throttle cable end from the throttle drum remove the cable from the housing by removing the lock nut and adjuster.

Loosen the throttle housing mounting bolts and remove the throttle drum from the handlebar.

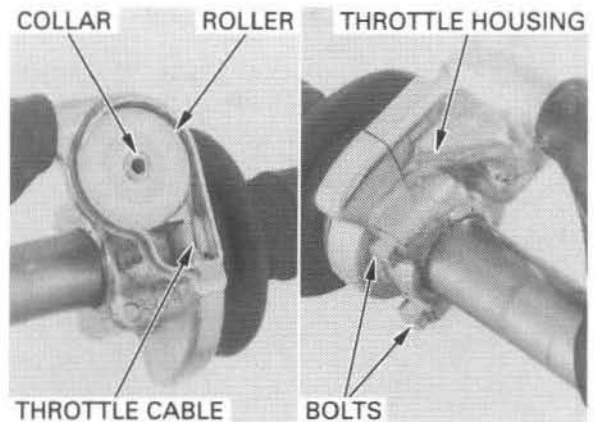

Remove the handlebar holder bolts, upper holders and handlebar.

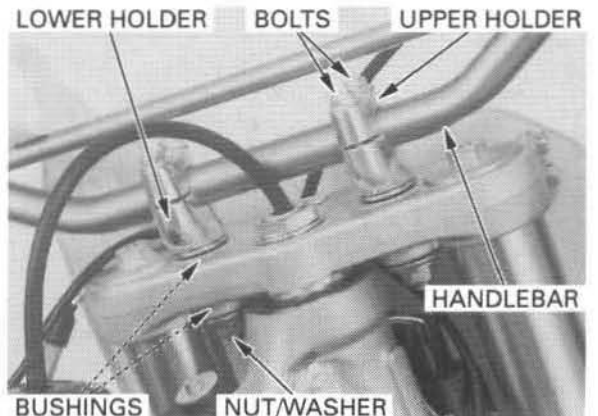

FRONT WHEEL/SUSPENSION/STEERING

If replace the handlebar grips as follows:
Apply Honda Bond A or Honda Hand Grip Cement (U.S.A. only) to the inside surface of the grips and to the clean surface of the left handlebar and throttle pipe.

Wait three or five minutes and install the grips.
Rotate the grips for even application of the adhesive.

Allow the adhesive to dry for an hour before using.



After 2000:

Align the index mark on the throttle grip flange with the edge of the throttle drum.

Align the "△" mark on the left handlebar grip flange with the punch mark on the handlebar.

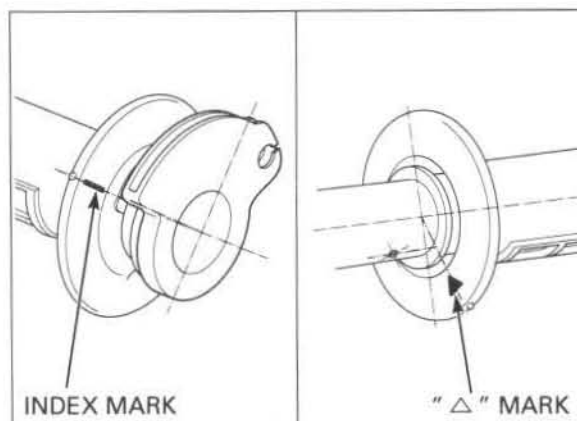

INSTALLATION

Install the bushings, lower holders, washers and handlebar holder nuts as shown (standard position).

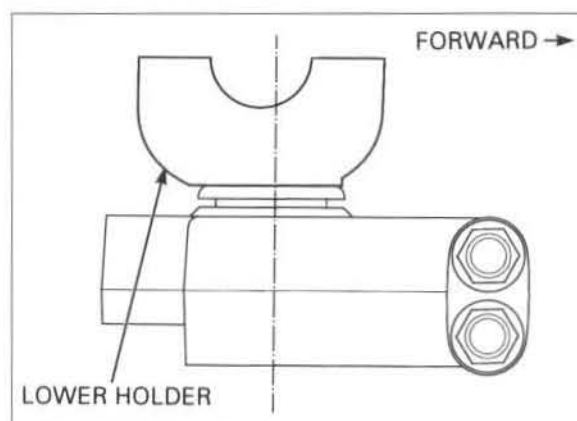

NOTE:

By turning the lower holder 180 degrees, you can install it 6 mm forward of the standard position. By installing the optional lower holder, you can set it 3 mm (0.12 in) forward of the standard position.

- Standard: 3 mm (0.12 in) offset to rearward
- Standard 180 degrees turn: 3 mm (0.12 in) offset to forward
- Optional: No offset

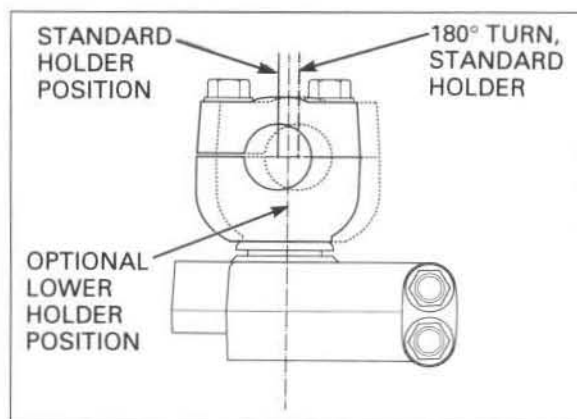

Temporarily install the handlebar and upper holders.
Tighten the lower holder nuts securely.

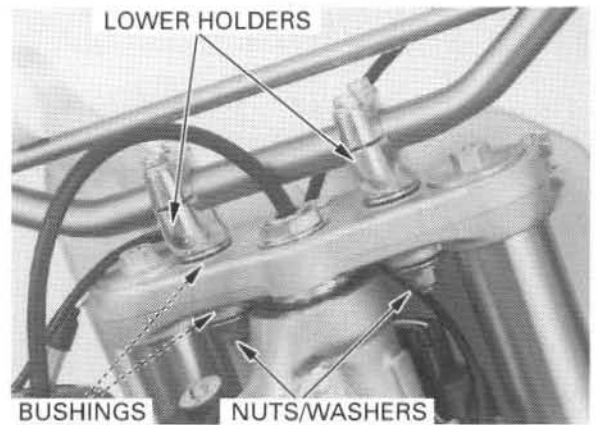

Align the punch mark on the handlebar with the top of the lower holder.

Place the upper holder on the handlebar with the punch marks facing forward.

Install and tighten the front handlebar holder bolts first, then tighten the rear bolts.

TORQUE: 22 N·m (2.2 kgf·m, 16 lbf·ft)

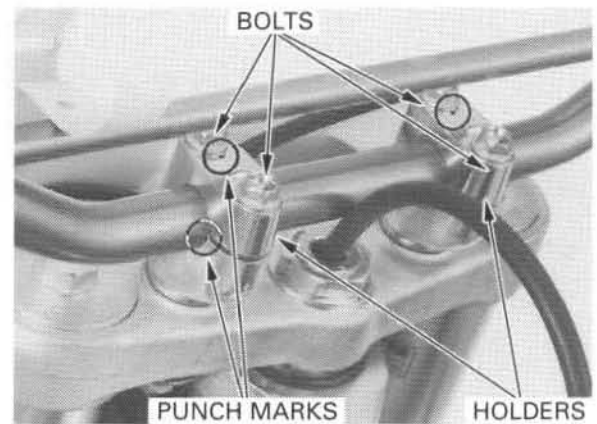

If you did not disassemble the throttle housing, place the dust cover over the throttle housing. Align the "△" mark on the dust cover with the punch mark on the handlebar. Tighten the throttle housing upper bolt first, then the lower bolt.

TORQUE: 9 N·m (0.9 kgf·m, 6.5 lbf·ft)

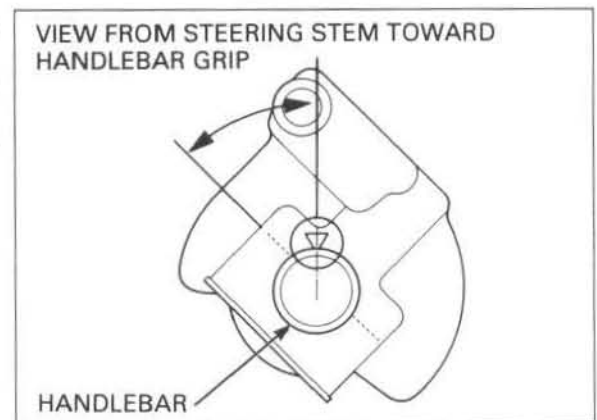

If you disassembled the throttle housing, install the throttle housing as follows:
Apply thin coat of oil to the sliding surface of the throttle grip and throttle housing.
Install the cable adjuster and lock nut into the throttle housing.

Connect the throttle cable end to the throttle drum.

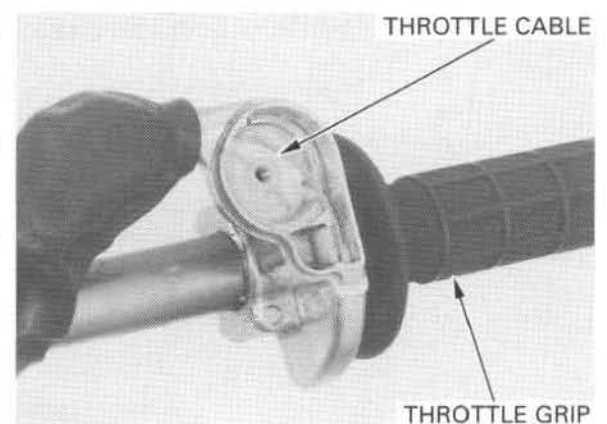

FRONT WHEEL/SUSPENSION/STEERING

Install the throttle housing by aligning the punch mark of the housing with the punch mark on the handlebar.
Tighten the upper bolt first, then the lower bolt.

TORQUE: 9 N·m (0.9 kgf·m, 6.5 lbf·ft)

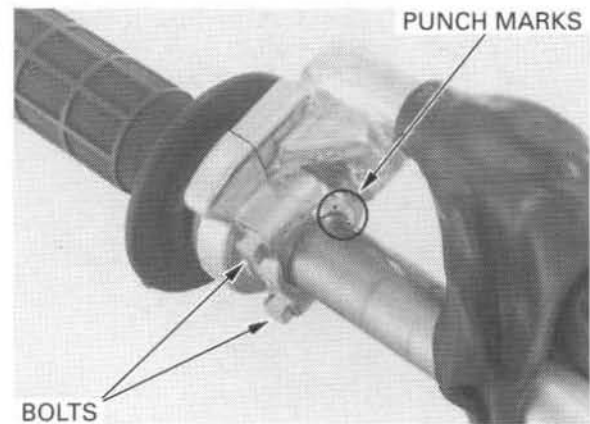

Install the throttle cable roller and collar.
Install the throttle housing cover and tighten the screws to the specified torque.

TORQUE: 2 N·m (0.2 kgf·m, 1.4 lbf·ft)

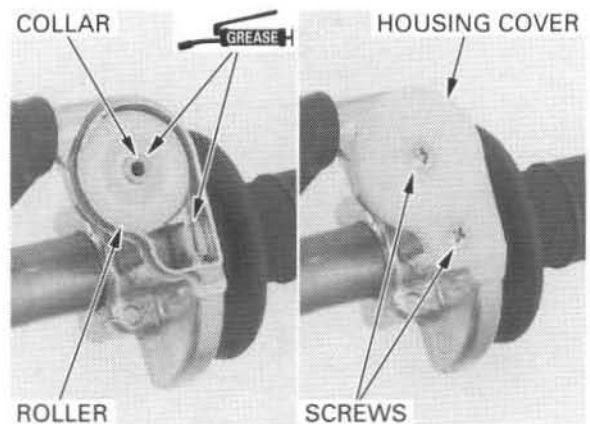

Place the dust cover over the throttle housing.
Align the "△" mark on the dust cover with the punch mark on the handlebar.
Tighten the throttle housing upper bolt first, then the lower bolt.

TORQUE: 9 N·m (0.9 kgf·m, 6.5 lbf·ft)

Adjust the throttle grip free play (page 3-5)

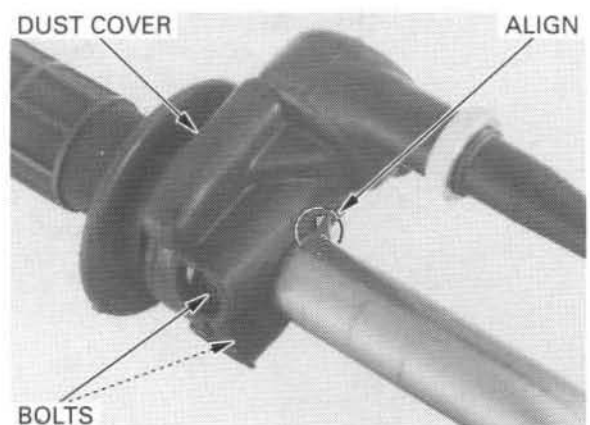

Position the brake master cylinder on the handlebar.

Install the master cylinder holder with the "UP" mark up and align the end of the holder with the punch mark on the handlebar.

Tighten the upper master cylinder holder bolt first, then tighten the lower bolt.

TORQUE: 10 N·m (1.0 kgf·m, 7 lbf·ft)

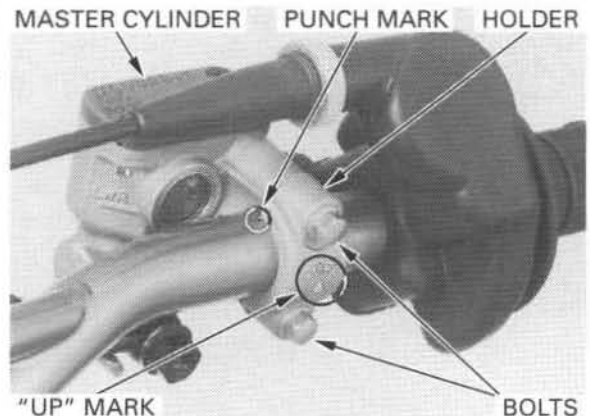

Install the clutch lever bracket and holder with the punch mark on the holder facing up. Align the end of holder with the punch mark on the handlebar. Tighten the upper bolt first, then the lower bolt.

TORQUE: 9 N·m (0.9 kgf·m, 6.5 lbf·ft)

Connect the clutch cable.

Adjust the clutch lever free play (page 3-15).

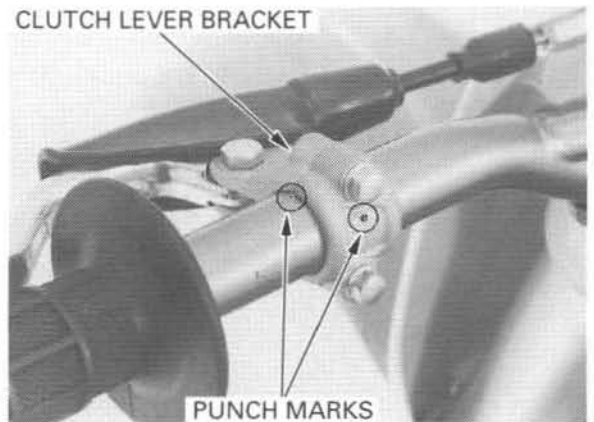

Route the engine stop button wire. Install the engine stop button on the handlebar and align the end of engine stop button holder with the punch mark on the handlebar. Install and tighten the engine stop button screw with the ground wire.

TORQUE: 2 N·m (0.2 kgf·m, 1.4 lbf·ft)

Attach the engine stop button wire to the handlebar using the wire bands.

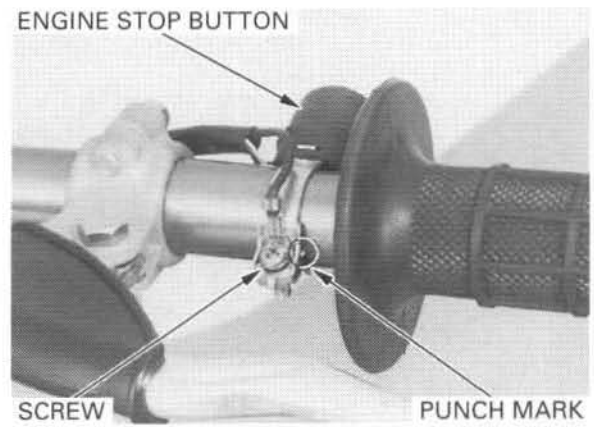

Route the number plate tab around the handlebar cross bar as shown.

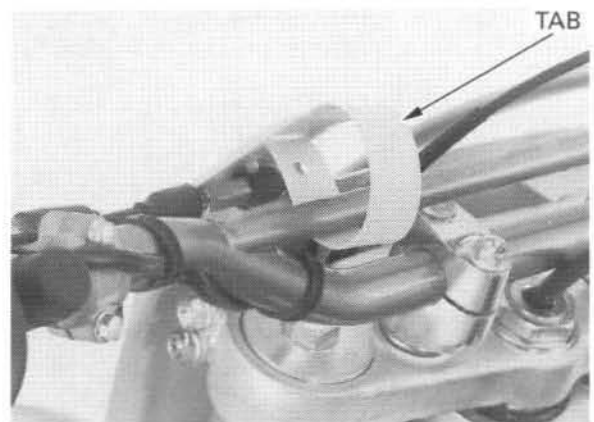

STEERING STEM

REMOVAL

Remove the number plate (page 2-3).
Remove the handlebar (page 11-24).
Remove the front wheel (page 11-4).

Remove the fender bolts, collars and washers.
Remove the front fender and brake hose guide.

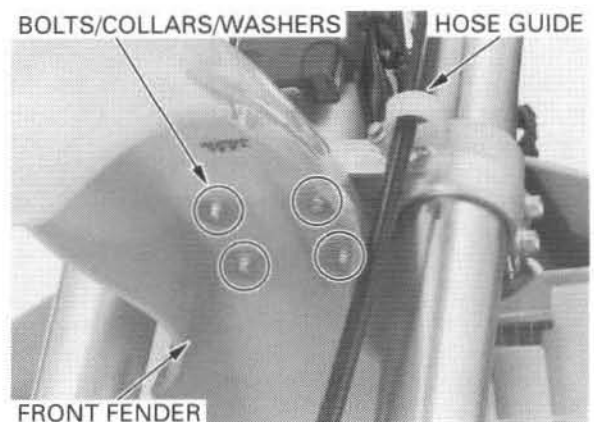

FRONT WHEEL/SUSPENSION/STEERING

Remove the steering stem nut and washer.

Remove the fork legs (page 11-9).

Remove the fork top bridge.

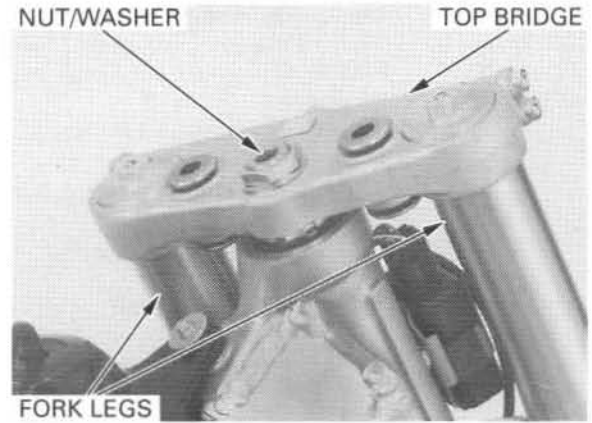

Remove the steering stem adjusting nut.

TOOLS:

Steering stem socket 07916 - 3710101 or
Adjustable pin spanner wrench 07702 - 0020001

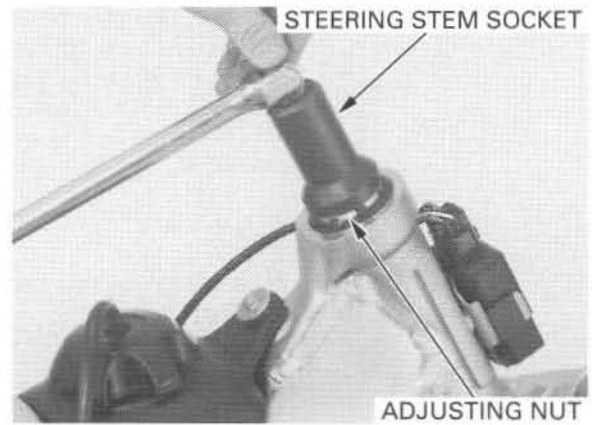

Remove the steering stem.

Remove the dust seal, upper tapered roller bearing.

Check the head bearings, outer races for wear or damage.

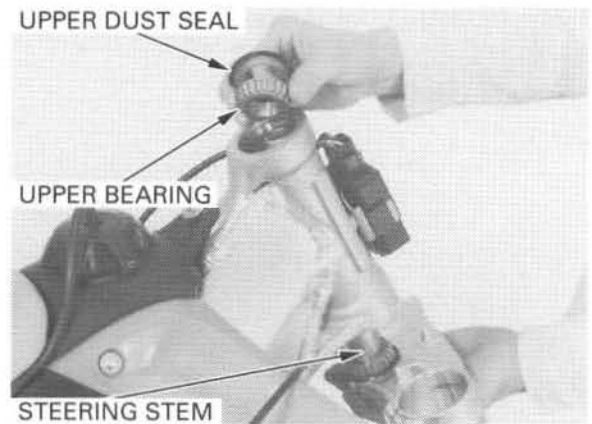

BEARING REPLACEMENT

Always replace the bearings and bearing races as a set.

Remove the upper and lower bearing outer races from the head pipe.

TOOL:

Ball race remover 07946 - 3710500 or
Driver handle 07949 - 3710001 and
Attachment, 28 x 30 mm 07946 - 1870100

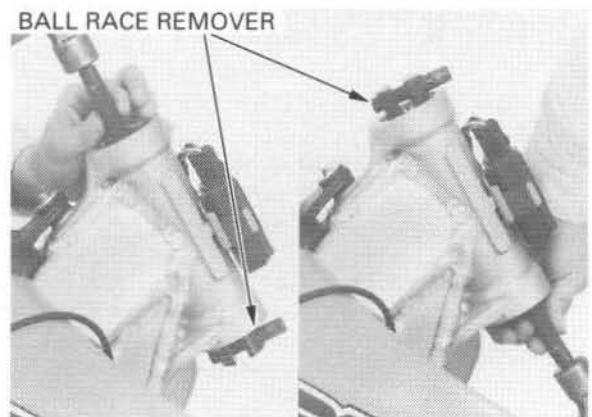

Install a new lower outer race, bearing race installer and install shaft as shown.
Hold the shaft with a wrench, turn the installer to install the lower outer race.

TOOLS:

Bearing race installer (2 required)

07VMF - KZ30100

Installer shaft

07VMF - KZ30200

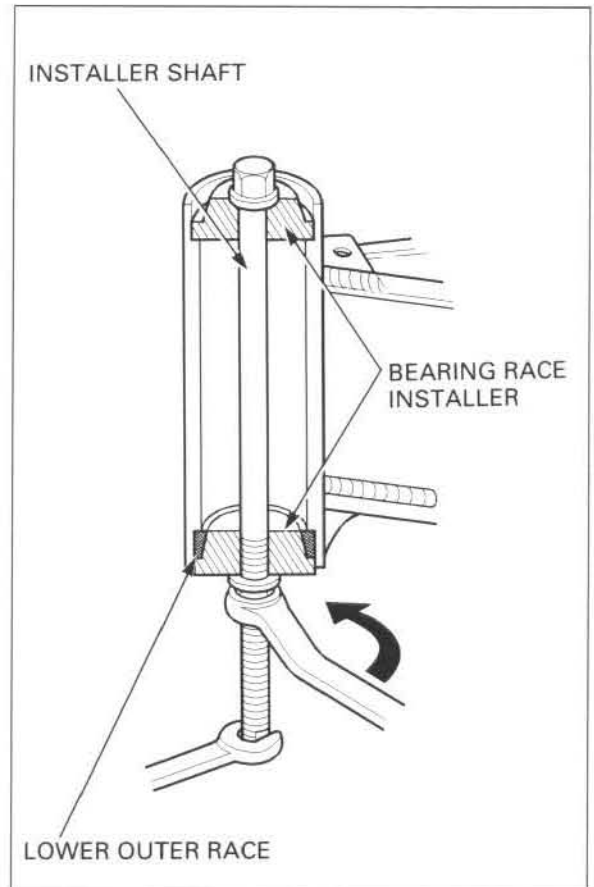

Install a new upper outer race, bearing race installer and install shaft as shown.
Hold the shaft with a wrench, turn the installer to install the upper outer race.

TOOLS:

Bearing race installer (2 required)

07VMF - KZ30100

Installer shaft

07VMF - KZ30200

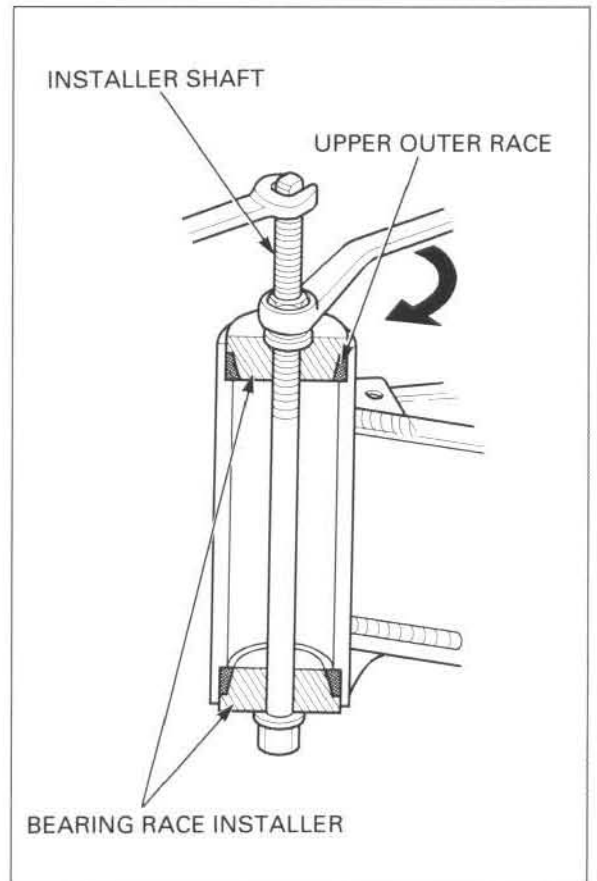

FRONT WHEEL/SUSPENSION/STEERING

Temporarily install the stem nut to avoid damaging the steering stem threads.

Remove the lower tapered roller bearing and dust seal from the steering stem.

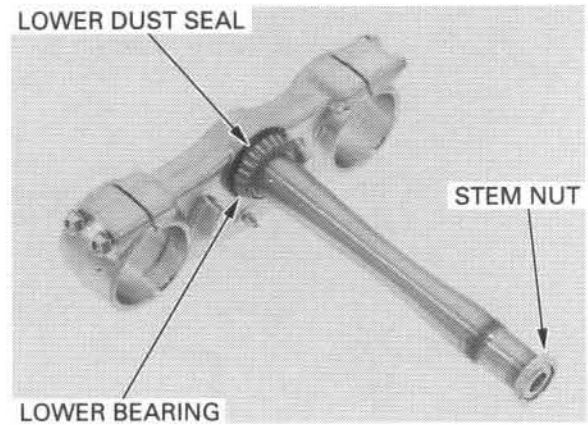

Install the new dust seal.

Pack the upper and new lower tapered roller bearings with grease.

Install the lower bearing using a hydraulic press and special tool as shown.

TOOL:

Attachment, 30 mm I.D. 07746 - 0030300

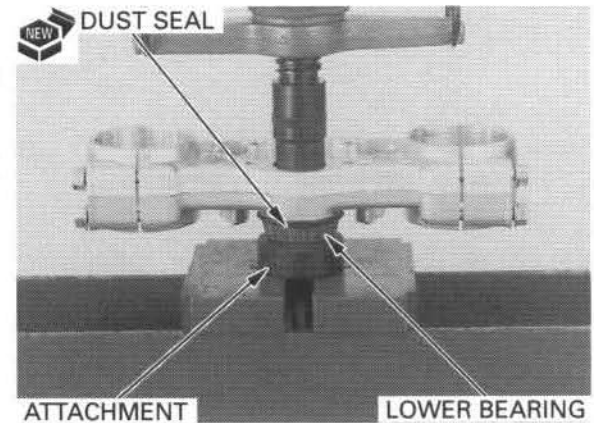

INSTALLATION

Apply grease to all of the bearing area.

Install the upper tapered roller bearing in the steering head.

Slide the steering stem into the steering head from the bottom.

Install the dust seal.

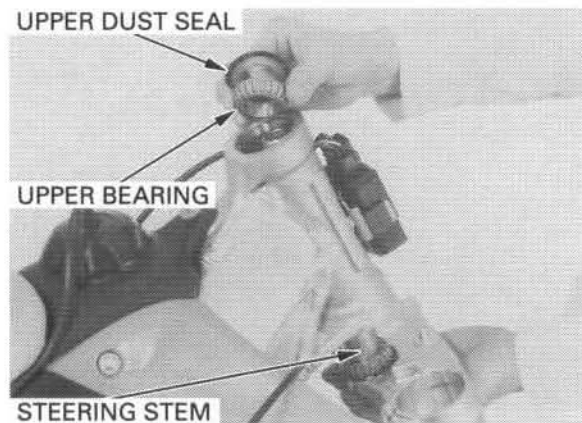

Install the steering head adjusting nut.

Tighten the steering head adjusting nut with the steering stem socket.

TORQUE: 7 N·m (0.7 kgf·m, 5.1 lbf·ft)

TOOL:

Steering stem socket 07916 - 3710101 or
Adjustable pin spanner wrench 07702 - 0020001

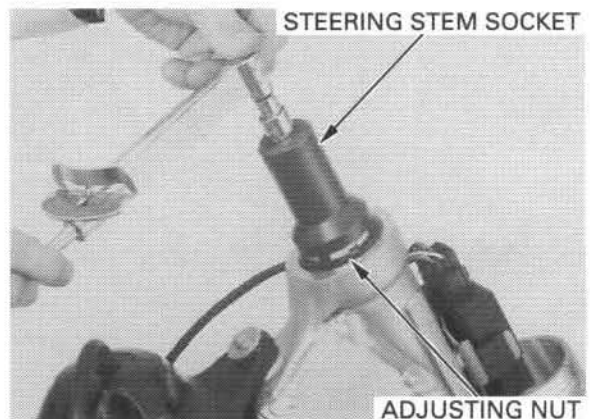

Turn the steering stem lock-to-lock five times to seat the bearings, then tighten the adjusting nut again.



Install the following:

- Top bridge
- Fork legs (page 11-22)
- Washer onto the top bridge

Install and tighten the stem nut to the specified torque.

TORQUE:

- 2000: 147 N·m (15.0 kgf·m, 108 lbf·ft)
- After 2000: 108 N·m (11.0 kgf·m, 80 lbf·ft)

Recheck the steering stem adjustment.

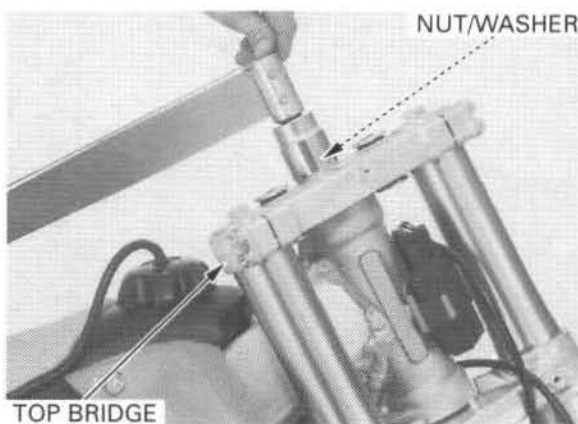

Turning the bridge side-to-side and check for smoothness and no binding.

Install the brake hose guide and tighten the bolt to the specified torque.

TORQUE: 5 N·m (0.5 kgf·m, 3.6 lbf·ft)

Install the front fender, washers, collars and tighten the bolts.

Install the following:

- Number plate (page 2-3)
- Front wheel (page 11-8)
- Handlebar (page 11-26)

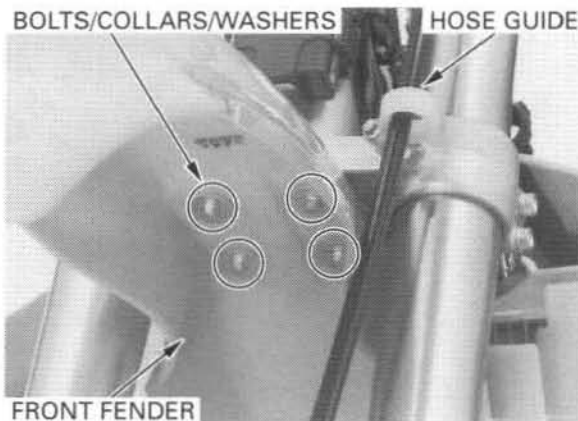

REAR WHEEL/SUSPENSION

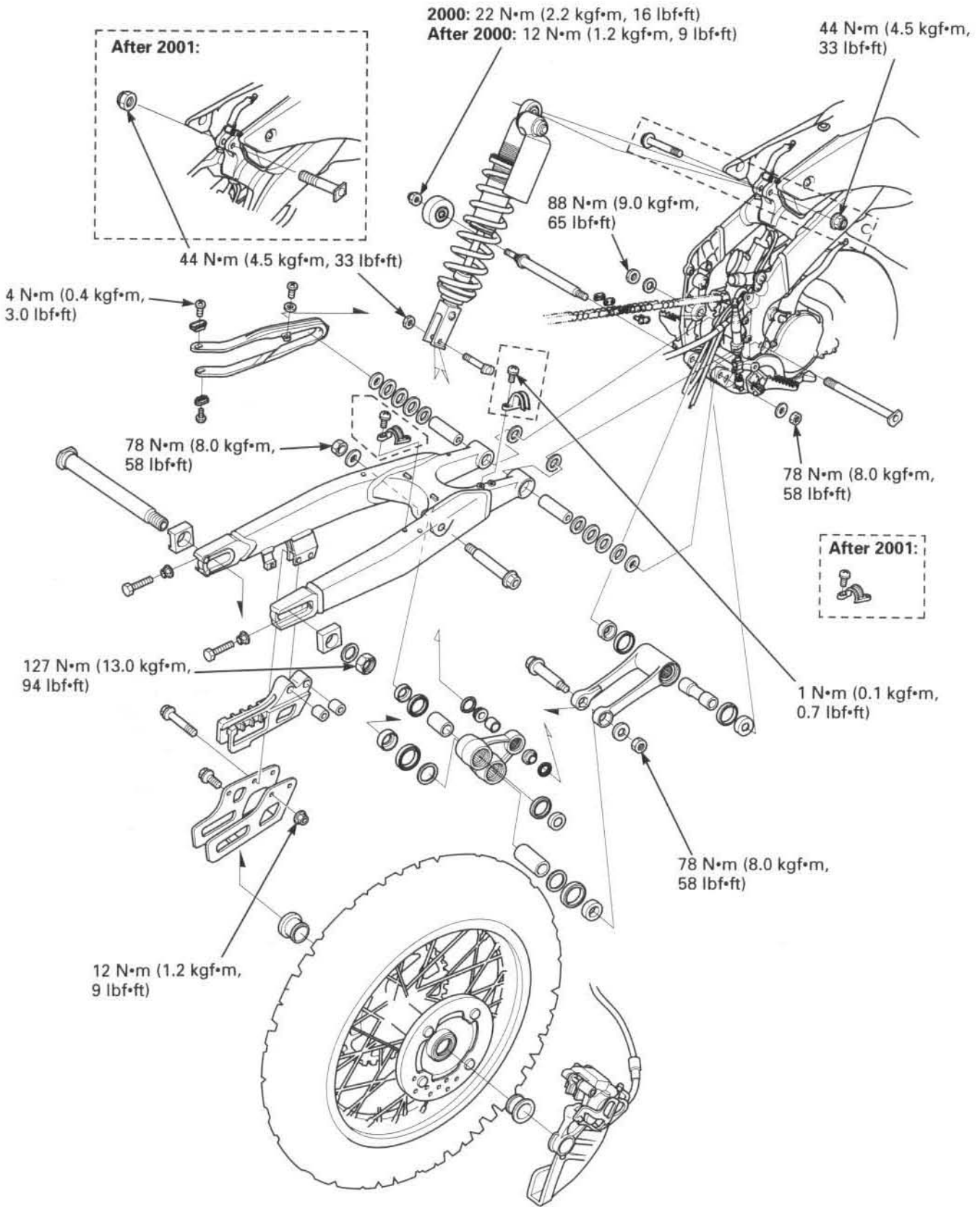

12. REAR WHEEL/SUSPENSION

SERVICE INFORMATION	12-1	SHOCK ABSORBER	12-10
TROUBLESHOOTING	12-3	SHOCK LINKAGE	12-26
REAR WHEEL	12-4	SWINGARM	12-31

SERVICE INFORMATION

GENERAL

⚠ WARNING

- Use only nitrogen to pressurize the shock absorber. The use of an unstable gas can cause a fire or explosion resulting in serious injury.
- The shock absorber contains nitrogen under high pressure. Do not allow fire or heat near the shock absorber.
- Before disposal of the shock absorber, release the nitrogen by pressing the valve core. Then remove the valve from the shock absorber.

Keep grease off of the brake pads and disc.

⚠ WARNING

A contaminated brake disc or pad reduces stopping power. Discard contaminated pads and clean a contaminated disc with a high quality brake degreasing agent.

- When servicing the rear wheel, support the motorcycle using a safety stand or hoist.
- For optimum suspension performance and linkage component service life, the swingarm and shock linkage pivot bearings (along with related seals and bushings) should be disassembled, cleaned, inspected for wear and lubricated with multipurpose grease NLGI No.2 (molybdenum disulfide additive) every 3 races or after 7.5 hours of running.
- Optional rear wheel sprockets, drive chain, shock springs and spring preload pin spanners are available. Refer to General Information, Section 1.
- Refer to section 13 for brake system information.
- Use genuine Honda replacement bolts and nuts for all suspension pivots and mounting points.

12

REAR WHEEL/SUSPENSION

SPECIFICATIONS

Unit: mm (in)

ITEM		STANDARD		SERVICE LIMIT
Cold tire pressure		100 kPa (1.0 kgf/cm ² , 14 psi)		_____
Axle runout		_____		0.20 (0.008)
Wheel rim runout	Radial	_____		2.0 (0.08)
	Axial	_____		2.0 (0.08)
Wheel hub-to-rim distance		51.00 (2.008)		_____
Drive chain slack		25 – 35 (1 – 1-3/8)		_____
Drive chain size/link	DID	2000:	520DM – 116	_____
		2001:	520DMA2 – 116	_____
		After 2001:	520DMA2 – 114	_____
	RK	2000:	520KZ6 – 116	_____
Drive chain slider thickness		_____		5 (0.2)
Drive chain roller O.D.		_____		25 (1.0)
Shock absorber	Damper gas pressure		981 kPa (10.0 kg/cm ² , 142 psi)	_____
	Damper compressed gas		Nitrogen gas	_____
	Damper rod compressed force at 10 mm compressed		18.1 – 22.1 kg (39.90 – 48.72 lbf)	_____
	Spring direction		Narrow wound end of coil facing down	_____
	Spring installed length (standard)	2000:	265 (10.4)	_____
After 2000:		267 (10.5)	_____	
High speed side compression damping adjuster standard position	2000 – 2001:	10/12 – 1-2/10 turns out from full in	_____	
	After 2001:	1-1/6 – 1-1/2 turns out from full in	_____	
Low speed side compression damping adjuster standard position	2000:	9 – 12 clicks out from full in	_____	
	2001:	8 – 11 clicks out from full in	_____	
	After 2001:	11 – 14 clicks out from full in	_____	
Rebound damping adjuster standard position	2000 – 2001:	22 – 26 clicks out from full in	_____	
	After 2001:	18 – 22 clicks out from full in	_____	

TORQUE VALUES

Rear axle nut	127 N•m (13.0 kgf•m, 94 lbf•ft)	U-nut.
Rear spoke nipple	4 N•m (0.4 kgf•m, 3.0 lbf•ft)	
Rear rim lock	13 N•m (1.3 kgf•m, 9 lbf•ft)	
Rear brake disc bolt (2000 – 2001:)	42 N•m (4.3 kgf•m, 31 lbf•ft)	Apply a locking agent to the threads.
Rear brake disc bolt/nut (After 2001:)	16 N•m (1.6 kgf•m, 12 lbf•ft)	
Final driven sprocket nut	32 N•m (3.3 kgf•m, 24 lbf•ft)	U-nut.
Rear wheel bearing retainer	44 N•m (4.5 kgf•m, 33 lbf•ft)	
Swingarm pivot nut	88 N•m (9.0 kgf•m, 65 lbf•ft)	
Shock arm (Swingarm side)	78 N•m (8.0 kgf•m, 58 lbf•ft)	U-nut.
	(Shock link side)	78 N•m (8.0 kgf•m, 58 lbf•ft)
Shock link (frame side)	78 N•m (8.0 kgf•m, 58 lbf•ft)	U-nut.
Shock absorber mounting nut	44 N•m (4.5 kgf•m, 33 lbf•ft)	U-nut.
Shock absorber spring lock nut	29 N•m (3.0 kgf•m, 22 lbf•ft)	
Drive chain roller bolt (2000:)	22 N•m (2.2 kgf•m, 16 lbf•ft)	
	(After 2000)	12 N•m (1.2 kgf•m, 9 lbf•ft)
Drive chain guide mounting nut	12 N•m (1.2 kgf•m, 9 lbf•ft)	U-nut.
Drive chain slider screw	4 N•m (0.4 kgf•m, 3.0 lbf•ft)	Apply a locking agent to the threads.
Rear brake hose guide screw	1.2 N•m (0.12 kgf•m, 0.87 lbf•ft)	
Shock absorber damper rod end nut	26 N•m (2.7 kgf•m, 20 lbf•ft)	Stake.
Shock absorber damping adjuster	29 N•m (3.0 kgf•m, 22 lbf•ft)	Stake.

TOOLS

Spoke wrench, 6.5 mm (2000 – 2001:)	07701 – 0020400	or equivalent commercially available in U.S.A.
Spoke wrench, 6.6 mm	070MA – KZ30100	
Bearing retainer wrench body	07710 – 0010401	
Lock nut wrench, 20 x 24 mm	07716 – 0020100	
Attachment, 42 x 47 mm	07746 – 0010300	
Attachment, 24 x 26 mm	07746 – 0010700	
Attachment, 30 mm I. D.	07746 – 0030300	
Pilot, 17 mm	07746 – 0040400	
Pilot, 20 mm	07746 – 0040500	
Pilot, 25 mm	07746 – 0040600	
Pilot, 22 mm	07746 – 0041000	
Pilot, 19 mm	07746 – 0041400	
Bearing remover shaft	07746 – 0050100	
Driver	07749 – 0010000	
Attachment, 28 x 30 mm	07946 – 1870100	
Spherical bearing driver	07946 – KA30200	Not available in U.S.A.
Driver	07949 – 3710000	
Slider guide attachment	07MAG – SP00102	Not available in U.S.A.
Slider guide, 16 mm	07PMB – KZ40100	Not available in U.S.A.
Oil seal driver	07TMD – MAC0100 or 07TMD – MAC010A (U.S.A. only)	
Retainer wrench, ø48 x 15	07YMA – KZ40100 or 07HMA – KS70100 (U.S.A. only)	
Pin spanner, 4 mm	89201 – KS6 – 810 or 07702 – 0020001 (2 piece)	

TROUBLESHOOTING

Soft suspension

- Weak shock absorber spring
- Incorrect suspension adjustment
- Oil leakage from damper unit
- Tire pressure too low

Hard suspension

- Damaged shock absorber mounting bearing
- Bent damper rod
- Damaged swingarm pivot
- Bent swingarm pivot
- Incorrect suspension adjustment
- Tire pressure too high

Steers to one side or does not track straight

- Bent rear axle
- Axle alignment/chain adjustment not equal on both sides

Rear wheel wobbling

- Bent rim
- Worn rear wheel bearings
- Faulty tire
- Tire pressure too low
- Faulty swingarm pivot bearings

REAR WHEEL

REMOVAL

Support the motorcycle securely using a hoist or equivalent.

Remove the axle nut and washer and adjusting block.

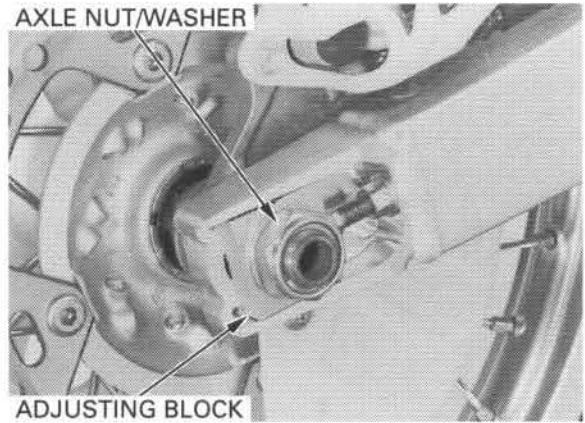

Push the rear wheel forward.
Derail the drive chain from the driven sprocket.

Remove the axle from the left side and remove the rear wheel.

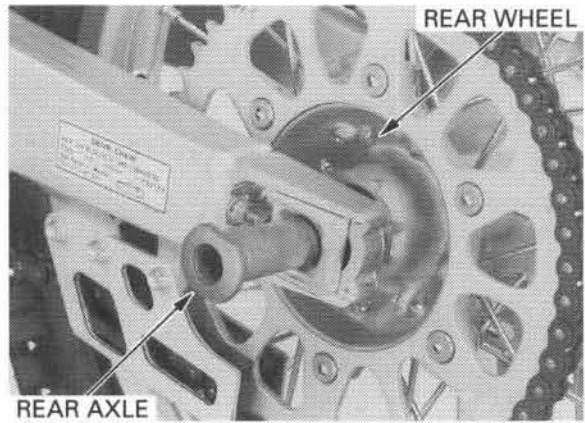

Remove the side collars.

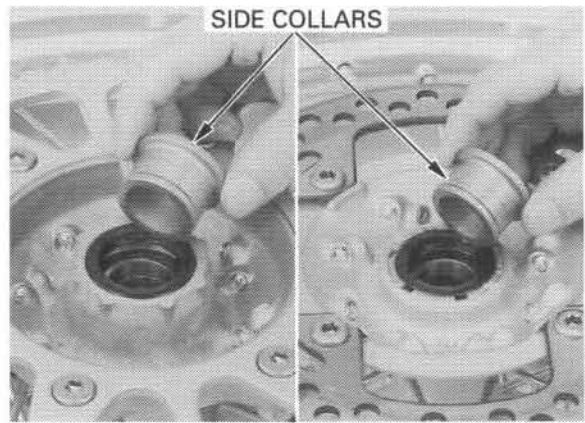

INSPECTION

AXLE

Place the axle in V-blocks and measure the runout. Actual runout is 1/2 the total indicator reading.

SERVICE LIMIT: 0.20 mm (0.008 in)

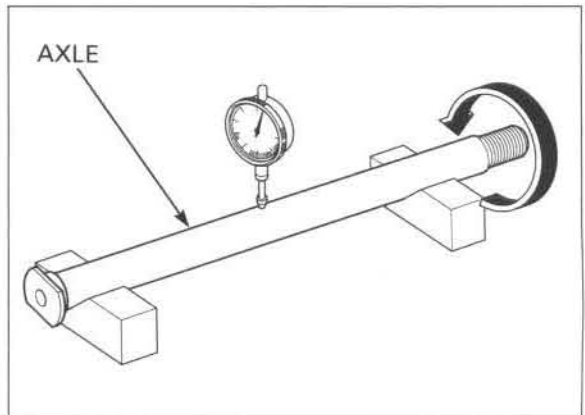

WHEEL BEARING

Turn the inner race of each bearing with your finger. Bearings should turn smoothly and quietly. Also check that the bearing outer race fits tightly in the hub.

Replace the wheel bearings in pairs.

Remove and discard the bearings if the races do not turn smoothly and quietly, or if they fit loosely in the hub.

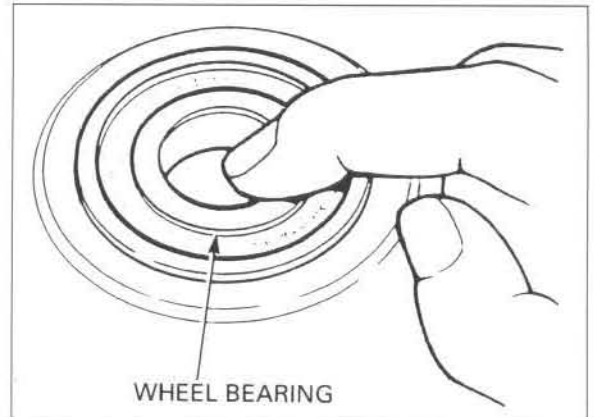

WHEEL RIM RUNOUT

Check the rim runout by placing the wheel in a turning stand. Spin the wheel slowly and read the runout using a dial indicator. Actual runout is 1/2 the total indicator reading.

SERVICE LIMITS: Radial: 2.0 mm (0.08 in)
Axial: 2.0 mm (0.08 in)

Check the spokes and tighten any that are loose.

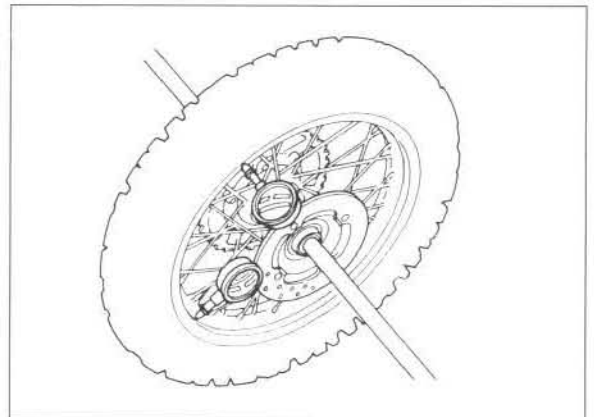

DISASSEMBLY

Remove the bolts (After 2001: bolts and nuts) and brake disc.
 Remove the right dust seal.

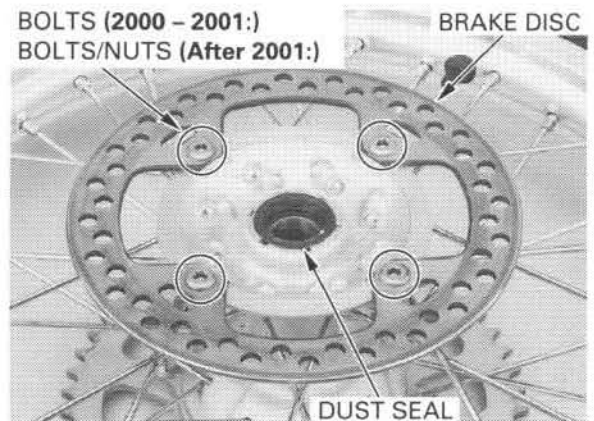

Remove the driven sprocket bolts, nuts and washers.
 Remove the driven sprocket.
 Remove the left dust seal.

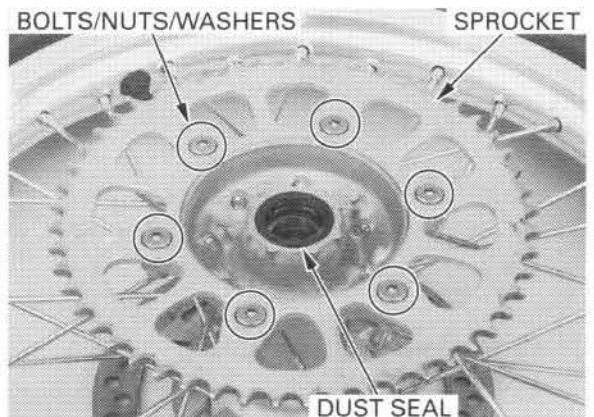

Place the rim on the work bench, with its directional arrow going counterclockwise.

Place the hub in the center of rim, and begin lacing with new spokes.

Adjust the hub position so that the distance from the hub left end surface to the side of rim is 51.00 mm (2.008 in) as shown.

Torque the spokes in two or three progressive steps.

TOOL:

Spoke wrench, 6.5 mm (2000 – 2001:) 07701 – 0020400 or equivalent commercially available in U.S.A.

Spoke wrench, 6.6 mm (After 2001) 070MA – KZ30100

TORQUE: 4 N·m (0.4 kgf·m, 3.0 lbf·ft)

Install the rim lock, rim band, tube and tire.

Torque the rim lock to the specified torque.

TORQUE: 13 N·m (1.3 kgf·m, 9 lbf·ft)

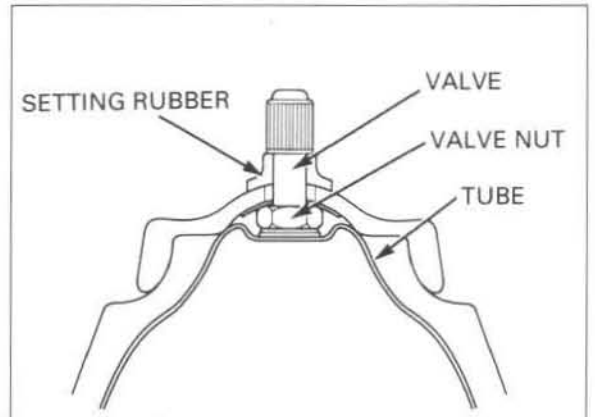
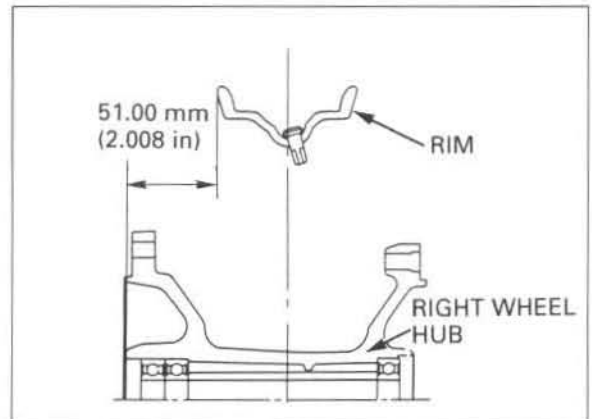

Pack the all bearing cavities with grease.

Drive in the new left inner and outer bearings using the special tools as shown.

TOOLS:

Driver 07749 – 0010000
Attachment, 42 x 47 mm 07746 – 0010300
Pilot, 25 mm 07746 – 0040600

Install the distance collar, then drive in the new right side bearing using the same tools.

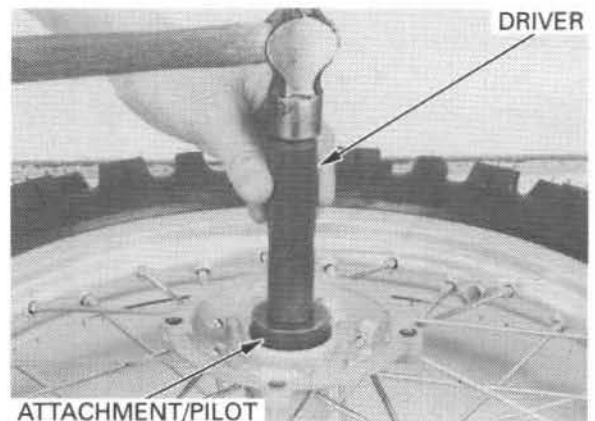

Apply grease to the bearing retainer and install it into the hub using the special tools.

TOOLS:

Retainer wrench body 07710 – 0010401
Retainer wrench, ø48 x 15 07YMA – KZ40100
 07HMA – KS70100 (U.S.A. only)

TORQUE: 44 N·m (4.5 kgf·m, 33 lbf·ft)

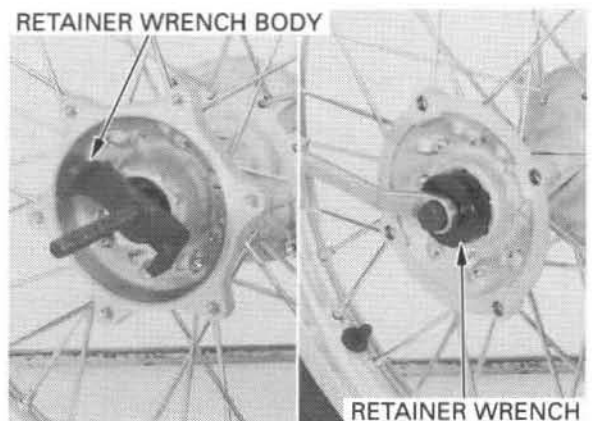

REAR WHEEL/SUSPENSION

Peen the edge of the retainer.

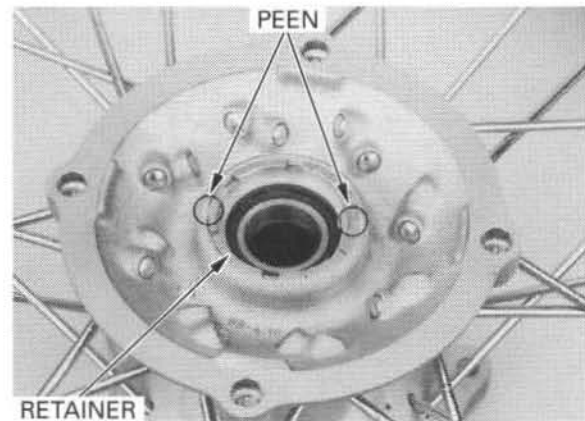

Install the driven sprocket.
Install the bolts, washers and nuts, then tighten the nuts to the specified torque.

TORQUE: 32 N•m (3.3 kgf•m, 24 lbf•ft)

Apply grease to the new left dust seal lips, then install it.

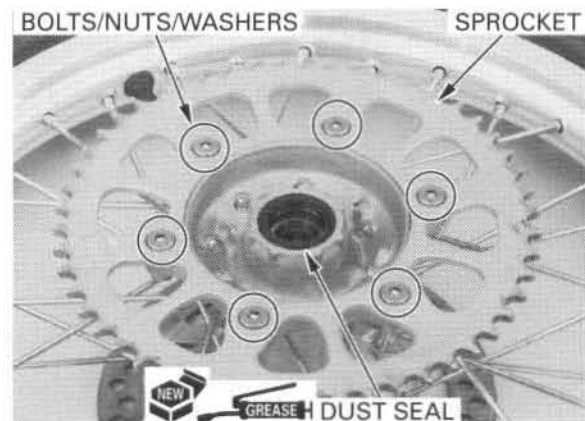

Install the brake disc with its "DRIVE" mark facing out.

2000 - 2001: Clean the brake disc bolt and apply Honda Anaerobic Thread Lock or equivalent to the threads.

Install and tighten the bolts (After 2001: bolts and nuts) to the specified torque.

TORQUE:
(2000 - 2001:) 42 N•m (4.3 kgf•m, 31 lbf•ft)
(After 2001:) 16 N•m (1.6 kgf•m, 12 lbf•ft)

Apply grease to the new right dust seal lips, then install it.

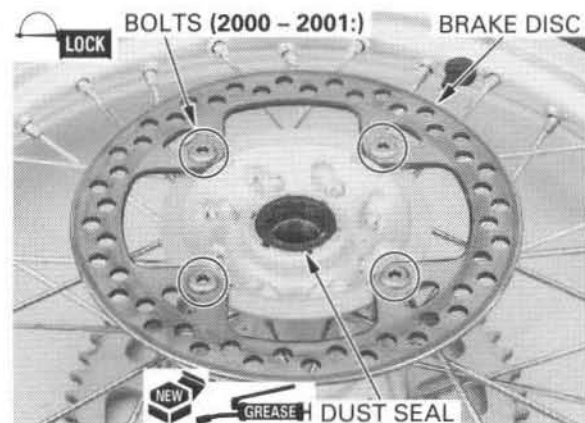

INSTALLATION

Apply grease to the inside of the side collars.

Install the side collars.

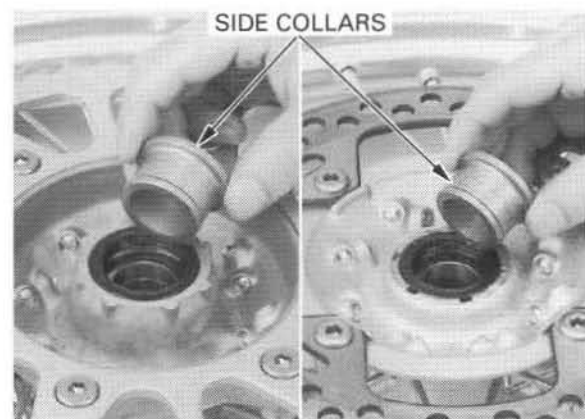

If removed, install the rear brake caliper bracket onto the slide rail of the swingarm.

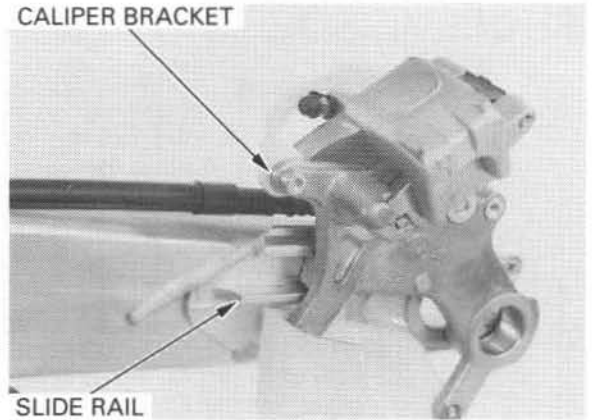

Place the rear wheel into the swingarm. Apply thin coat of grease to the axle. Install the axle from the left side. Install the drive chain over the driven sprocket.

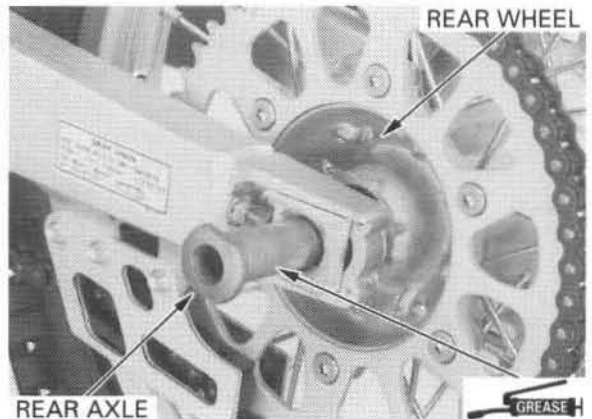

If the master link retaining clip was removed, install it on the drive chain with the closed end of the clip in the direction of wheel rotation.

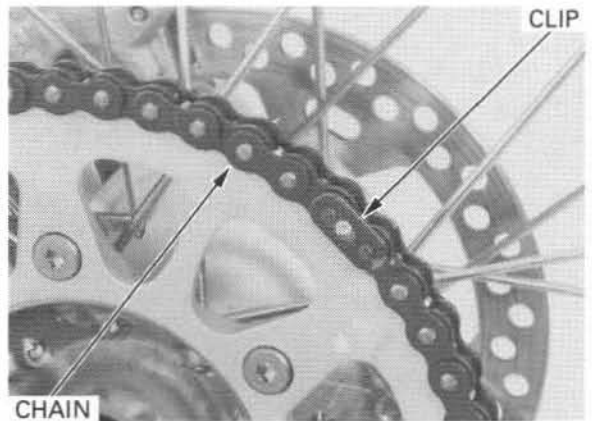

Install the adjusting block, washer and loosely install the axle nut.

Adjust the drive chain slack (page 3-11).

Tighten the axle nut to the specified torque.

TORQUE: 127 N·m (13.0 kgf·m, 94 lbf·ft)

Snug the adjusting bolts against the chain adjusters and tighten the lock nuts.

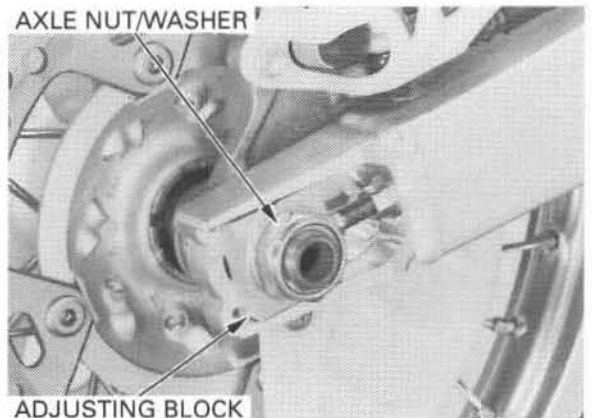

SHOCK ABSORBER

⚠ WARNING

- Use only nitrogen to pressurize the shock absorber. The use of an unstable gas can cause a fire or explosion resulting in serious injury.
- The shock absorber contains nitrogen under high pressure. Do not allow fire or heat near the shock absorber.
- Before disposal of the shock absorber, release the nitrogen by pressing the valve core. Then remove the valve from the shock absorber.

REMOVAL

Raise the rear wheel off the ground by placing a work-stand under the engine.

Remove the seat (page 2-2).
Remove the sub-frame (page 2-4).

NOTE:

If you plan to disassemble the shock absorber, loosen the spring lock nut and adjusting nut.

Remove the upper mounting bolt/nut.
Remove the shock absorber lower mounting bolt/nut and shock absorber.

DISASSEMBLY

NOTE:

Measure the spring length for installation later.

Hold the shock absorber in a vise by the upper mount, protected on both sides by pieces of wood.

Loosen the lock nut and adjusting nut.

TOOLS:

Pin spanner, 4 mm 89201 - KS6 - 810 x 2 or
07702 - 020001 x 2

Slide the rubber stopper down the damper rod and remove the spring seat stopper, spring seat and spring.

2000 - 2001
Shown: UPPER MOUNTING BOLT/NUT

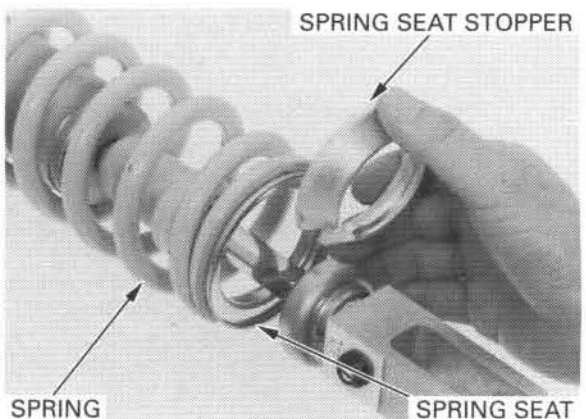
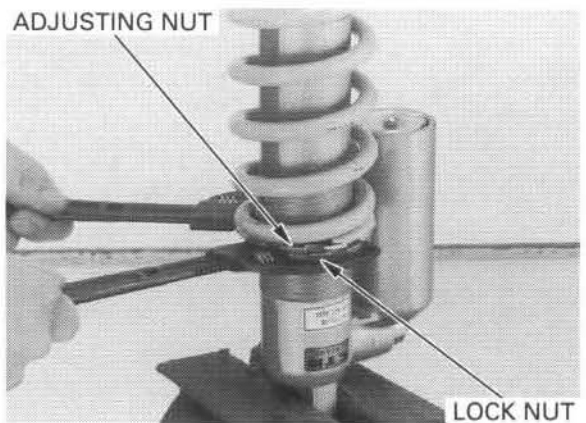
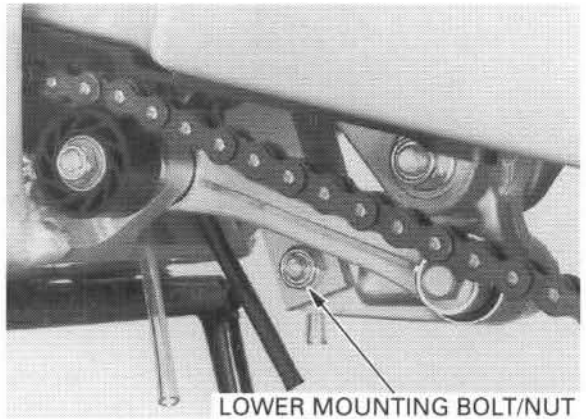
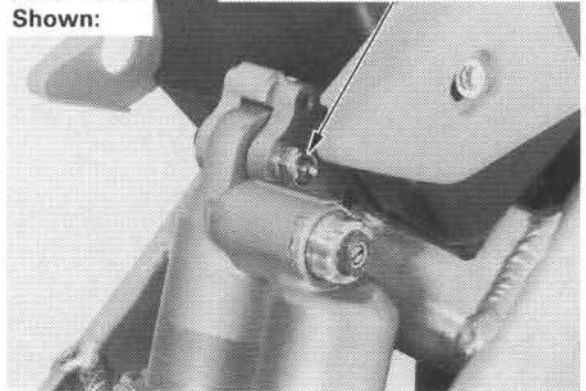

BLADDER REPLACEMENT

NOTE:

- Replace the bladder when oil leaks around the chamber cap or oil spills out when releasing the nitrogen from the reservoir.
- Perform this procedure before draining the oil from the damper.

Depress the valve core to release the nitrogen from the reservoir.

⚠ WARNING

- *Release all nitrogen pressure before disassembly; otherwise the chamber cap will be under significant pressure and could cause serious injury or death.*
- *Wear protective clothing and adequate eye protection against injury and prevent debris from getting in your eyes.*

Remove the valve core.

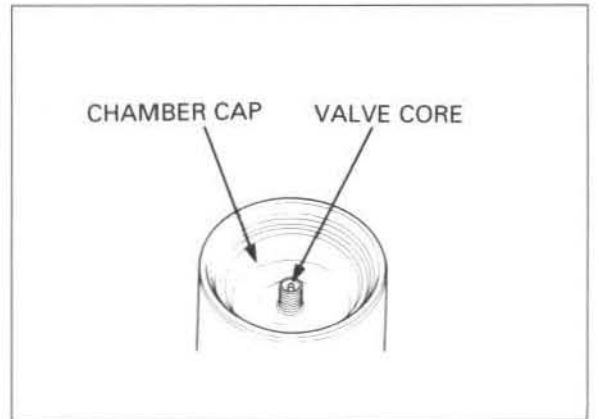
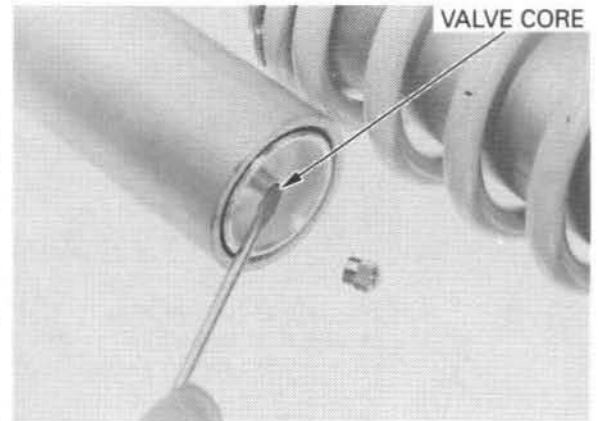

Put a suitable tool on the valve cap and push it in by lightly tapping on the tool with a plastic hammer until you have good access to the stop ring.

CAUTION:

To avoid damage the threads of the gas valve, install the cap before depressing the chamber cap.

NOTE:

Depress the chamber cap just the minimum amount necessary for stop ring access.

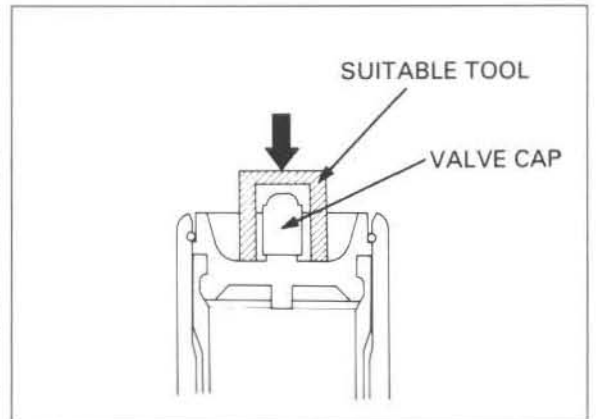

Two small screwdrivers and a shop towel are required to remove the stop ring.

The stop ring groove in the reservoir is ramped toward the inside to give the stop ring a square shoulder on which to seat securely.

CAUTION:

To avoid damaging the inside surfaces of the reservoir, cover the screwdriver with shop towel.

To remove the stop ring, first push one end of the stop ring out of its groove, then slip the second screwdriver between the stop ring and the reservoir to act as a ramp.

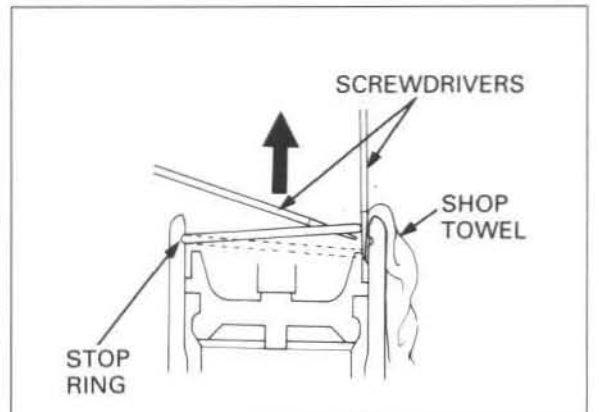

REAR WHEEL/SUSPENSION

Now, use the other screwdriver to pull the stop ring completely out.

NOTE:

Check the stop ring groove for burrs. Remove any burrs with the fine emery cloth before pulling the damper rod out of the case.

Hold the shock absorber in a vise protected with shop towel or soft jaws. Using a suitable squeeze bottle, fill the reservoir with the recommended shock oil.

RECOMMENDED SHOCK OIL: Pro-Honda HP Fork Oil 5W

Slowly pump the damper rod until no air bubbles appear in the valve core hole, then pull the damper rod all the way.

Install the valve core securely.

Remove the chamber cap and bladder following the procedure below:

1. Wrap the shop towel around the chamber cap. Compress the damper rod slowly, to force the chamber cap out.

CAUTION:

- *The chamber cap will be removed with hydraulic pressure so its force can be significant considering the air in the bladder.*
- *Wear protective clothing and a face guard to protect your eyes and face in case the chamber cap pops out quickly and forcibly.*

2. Place the damper in a vise with soft jaws with the damping adjuster facing up, being careful not to distort the damper body. Remove the damping adjuster.

CAUTION:

Do not overtighten the vise. Damage to the shock body will result.

3. Fill the damper with Pro-Honda HP Fork Oil 5W through the damping adjuster hole, while slowly pulling the damper rod out.
4. Reinstall the damping adjuster after filling the damper.

NOTE:

The damper must be kept upright to prevent oil from leaking out of the damper.

5. Place the damper with the reservoir chamber cap facing up.

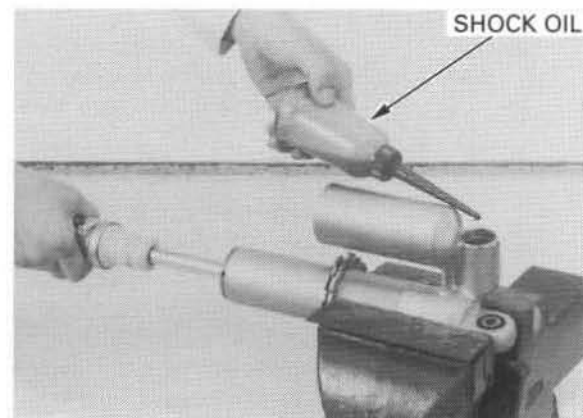
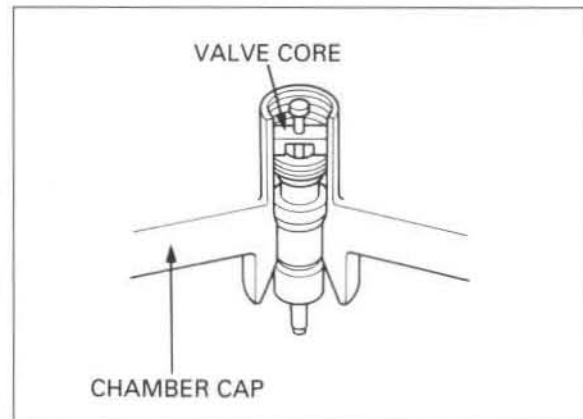
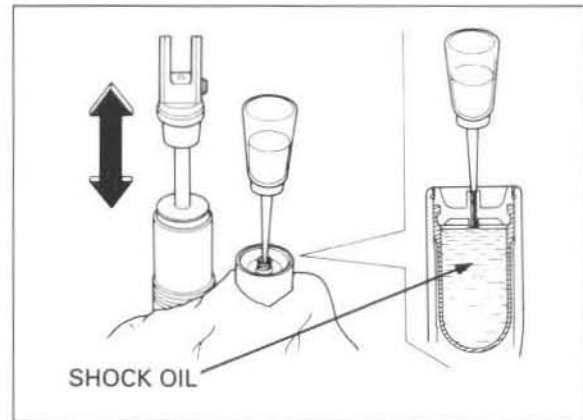

6. Repeat steps one to five until the chamber cap is removed from the reservoir.

Remove the bladder from the chamber cap.

CAUTION:

- *Do not use any sort of tool to remove the bladder, because it may damage the chamber cap.*
- *Replace the bladder with a new one. Do not reuse the removed one.*

Attach the new bladder to the chamber cap.

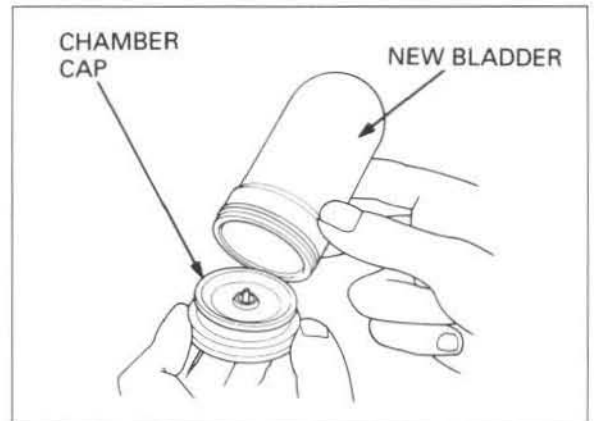

The bladder becomes distorted during installation, depress the valve core to reform it.

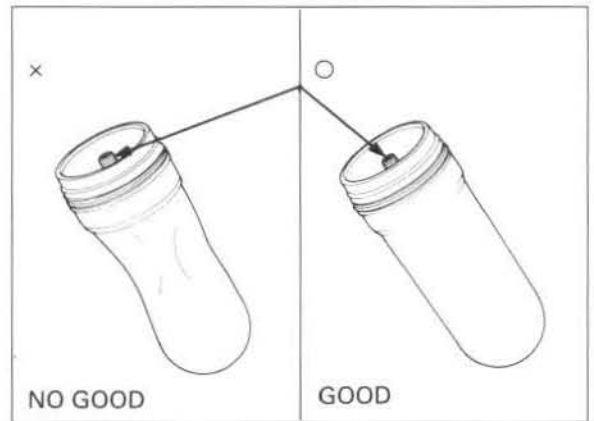

Clean the inside the reservoir and fill it with Pro-Honda HP Fork Oil 5W.

RECOMMENDED SHOCK OIL: Pro-Honda HP Fork Oil 5W

Apply a light coating of shock oil to the lip of the bladder, and press the chamber cap into the reservoir to about 1 – 2 mm (0.04 – 0.08 in) below the stop ring groove.

Install the stop ring in the groove of the reservoir securely. Temporarily fill the reservoir with air slowly until the chamber cap seats against the stop ring.

⚠ WARNING

Be sure the stop ring is seated in the ring groove all the way around or the chamber cap can come apart when riding the motorcycle.

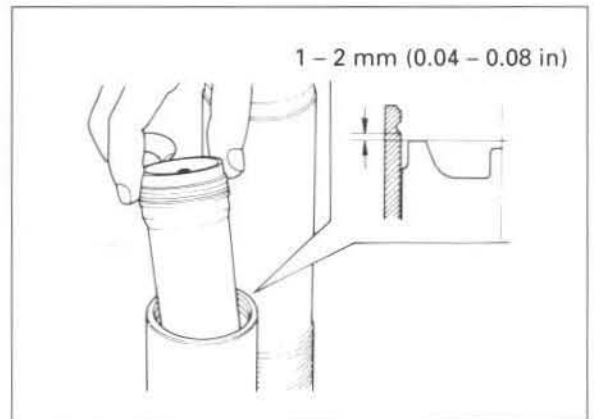

Then make sure that chamber cap face is level with the reservoir face.

⚠ WARNING

If the chamber cap does not seat fully, the chamber cap may fly out when filling the reservoir with nitrogen.

Release the air from the reservoir by depressing the valve core.

Bleed the air from the shock absorber bladder (page 12-21).

Fill the reservoir with nitrogen to the specified pressure (page 12-22).

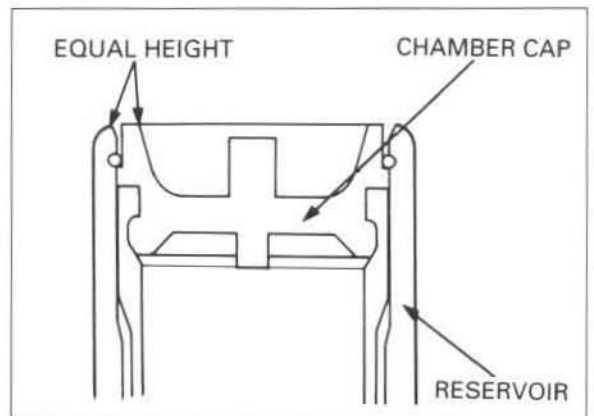

DAMPER DISASSEMBLY

Depress the valve core to release the nitrogen from the reservoir (page 12-11).

⚠ WARNING

- *Point the valve away from you to prevent debris getting in your eyes.*
- *Before disposal of the shock absorber, release the nitrogen by pressing the valve core. Then remove the valve from the shock absorber.*

Remove the damping adjuster.

TOOL:

Lock nut wrench, 20 x 24 mm 07716 - 0020100

Drain most of the shock oil from the damper and reservoir, by pumping the damper rod in and out several times.

DAMPING ADJUSTER

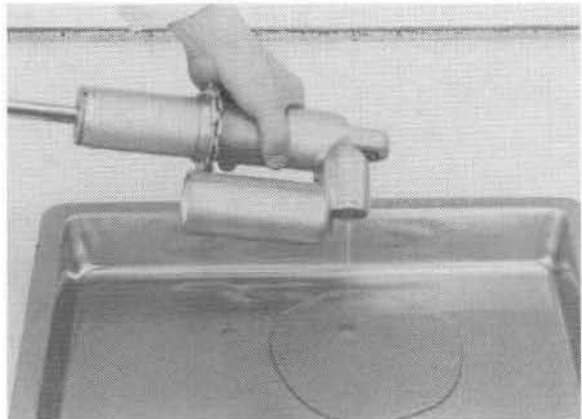
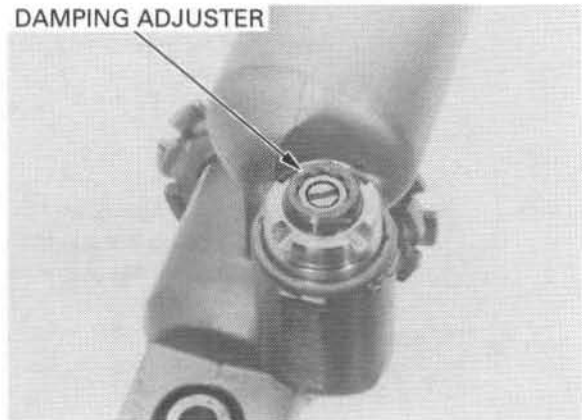

Clamp the shock absorber in a vise by the damper case protected on both sides by pieces of wood.

Remove the end plate and tape or tie it to the rubber stopper so it won't get in the way.

END PLATE

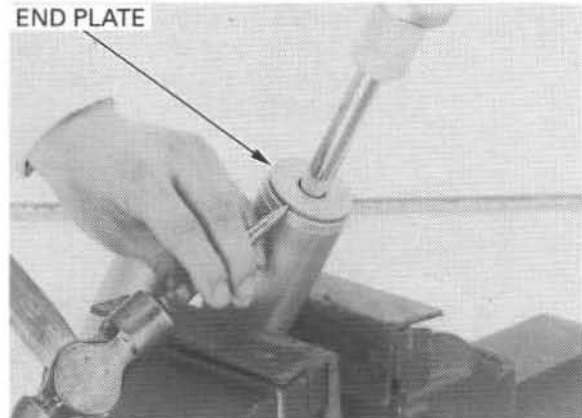

Push in the damper seal until you have good access to the stop ring.

Two small screwdrivers are required to remove the stop ring. The stop ring groove in the damper case is ramped towards the inside to give the stop ring a square shoulder on which to seat securely.

STOP RING

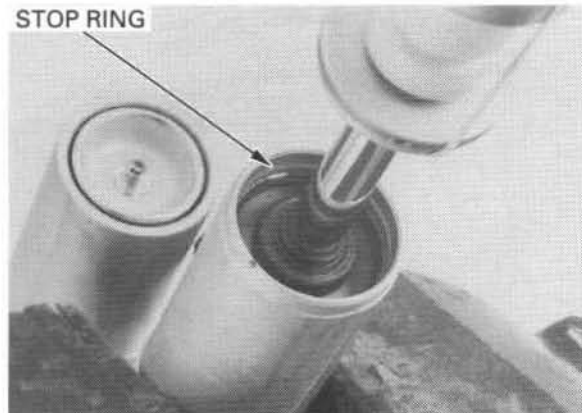

To remove the stop ring, first push one end of the stop ring out of its groove, then slip the second screwdriver between the stop ring and the damper case to act as a ramp. Now, use the other screwdriver to pull the stop ring completely out.

NOTE:

Check the stop ring groove for burrs. Remove any burrs with fine emery cloth pulling the damper rod out of the case.

CAUTION:

Burrs will damage the damper rod piston ring.

Carefully pull the damper rod assembly out of the damper case.

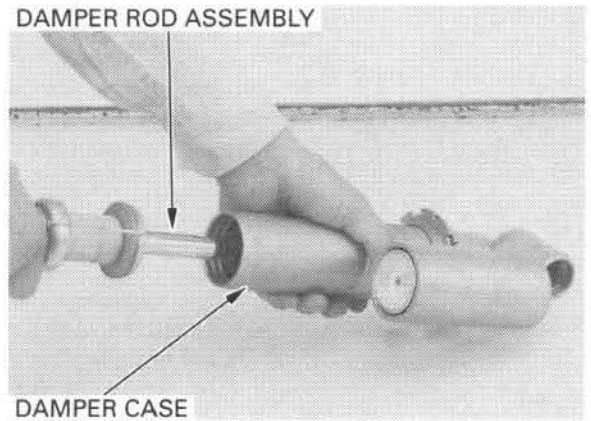
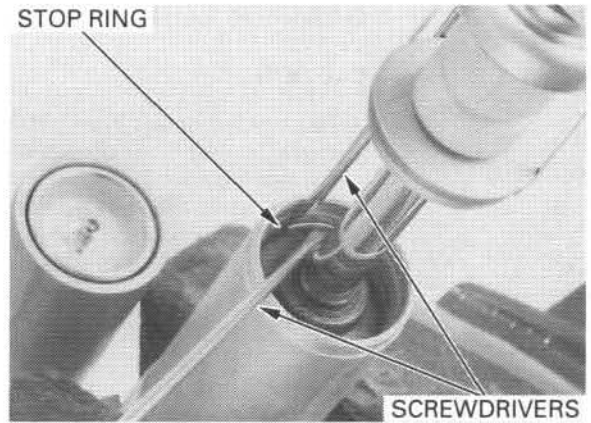

PISTON RING REPLACEMENT

Inspect the piston ring. If the piston ring is damaged, cut the piston ring and replace the piston ring and O-ring under the piston ring with a new one.

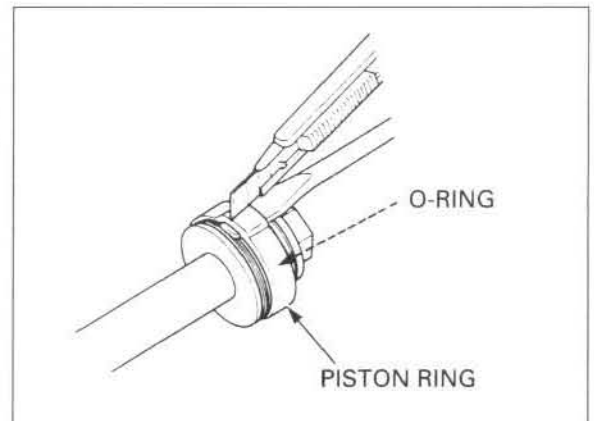

Place the slider guide attachment over the piston and install a new O-ring and piston ring onto place with your finger.

TOOL:

Slider guide attachment 07MAG – SP00102
not available in
U.S.A.

Compress the piston ring against the ring groove, and seat the piston ring into the ring groove.

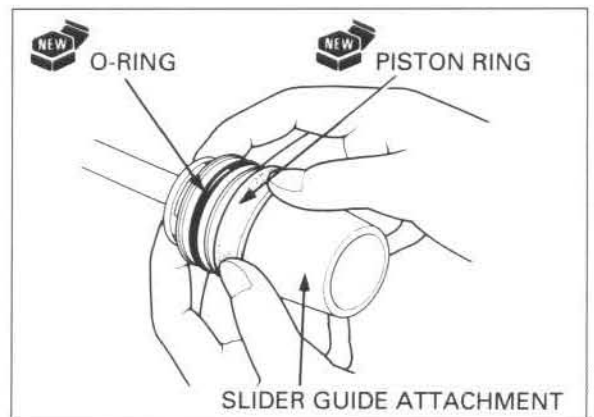

DAMPER ROD DISASSEMBLY

CAUTION:

- To keep lint or dirt from getting onto damper rod parts, do not wear gloves while working on the damper rod.
- Be careful to file the end nut by hand so that the O.D. of the rod end is about 10 mm (0.4 in). Be careful not to over-file.

Unstake the damper rod end nut with a file as shown.

Place the damper in a vise protected with a piece of wood or shop towel, being careful not to distort the lower mount.

Turn the end nut back-and-forth in 1/4 turn increments until it loosens, then rotate another 1/4 turn and repeat the back-and-forth until nut loosens completely.

NOTE:

- If the damper rod is cracked or damaged when removing the end nut, replace the damper rod assembly with a new one.
- Remove all the burrs from the end of the damper rod. Lean thoroughly with solvent. If the threads cannot be repaired, replace the rod.

Hold the lower shock mount in a vise with soft jaws, a piece of wood, or shop towel.

Remove the burrs from the damper rod end with a file and correct the threads with a die.

DIE: 12 x 1.5 mm

Clean the damper rod with solvent after correcting the threads.

NOTE:

Make sure that filings are not stuck in the damper rod I.D.

Remove the valve stopper, washers, rebound valves and piston from the damper rod.

NOTE:

- Use a piece of mechanic's wire to keep the valves in the correct order.
- Keep dust and abrasives away from all damper rod parts.
- Thoroughly clean the valves in solvent and blow them dry with compressed air if they have been disassembled and separated.
- Be careful not to get solvent on the O-ring and piston ring.
- The valve arrangement and number of valves shown is typical and may not represent this model exactly.

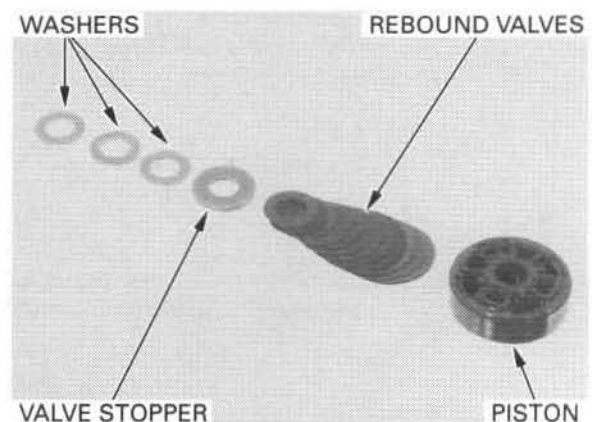
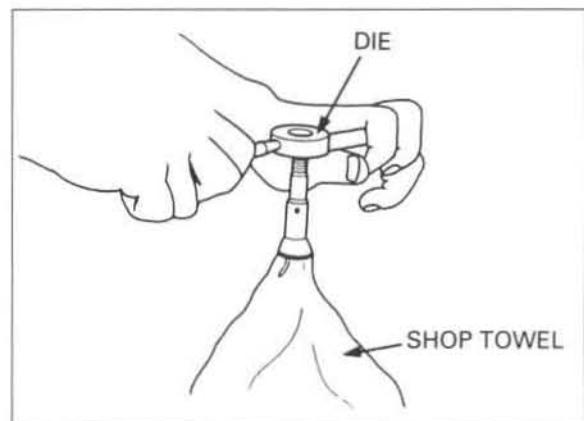
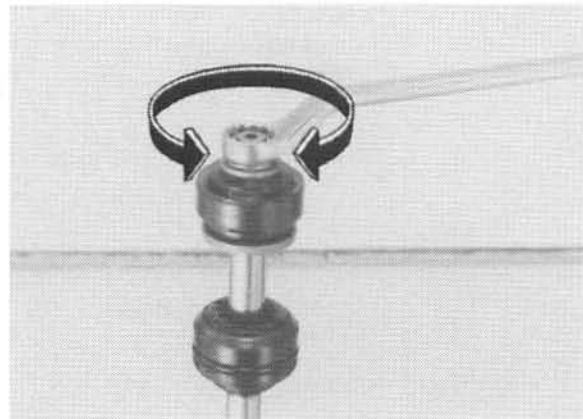
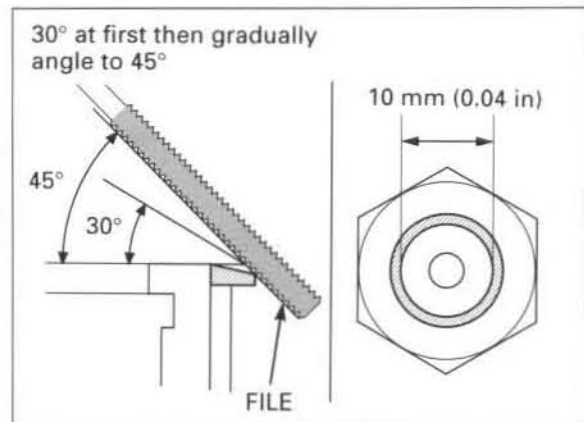

Remove the compression valves and valve stopper.

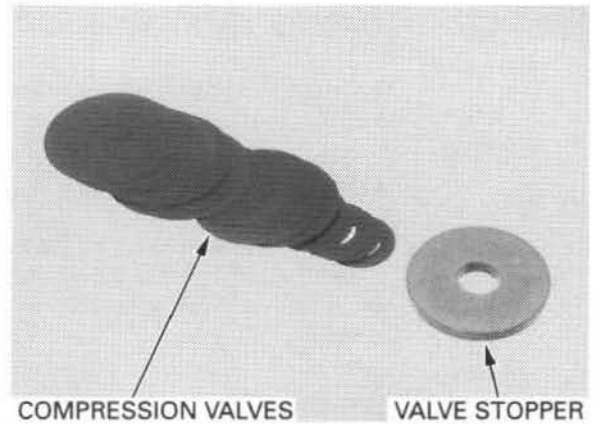

Chase the threads with a die and clean with oil.
Back out damping adjuster and back flush with solvent.
Reinstall adjuster.

Wrap the top threads of the damper rod with tape.

Remove the rod guide case from the damper rod.

Remove the end plate, rubber stopper and rubber seat from the damper rod.

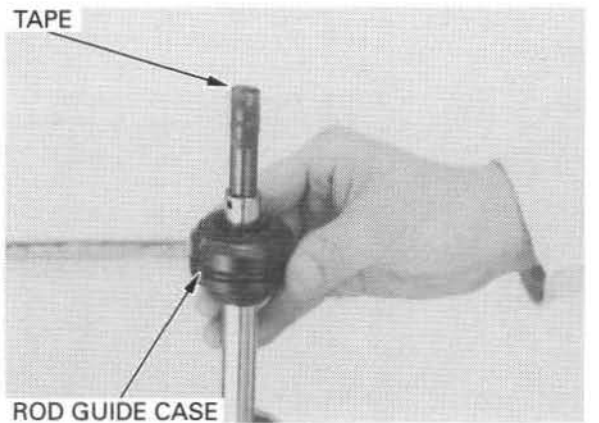

ROD GUIDE INSPECTION

Inspect the rebound rubber and dust seal lips for wear or damage and replace the rod guide case with a new one if necessary.

Visually inspect the rod guide case metal.
If the metal is worn so that the copper surface appears, replace the rod guide case with a new one.

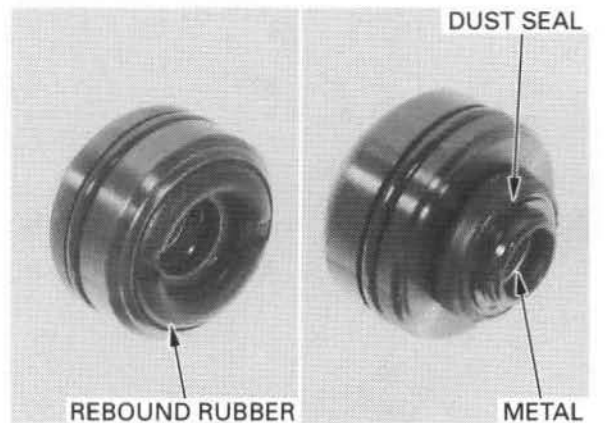

Remove the O-ring from the rod guide case and replace it with a new one.

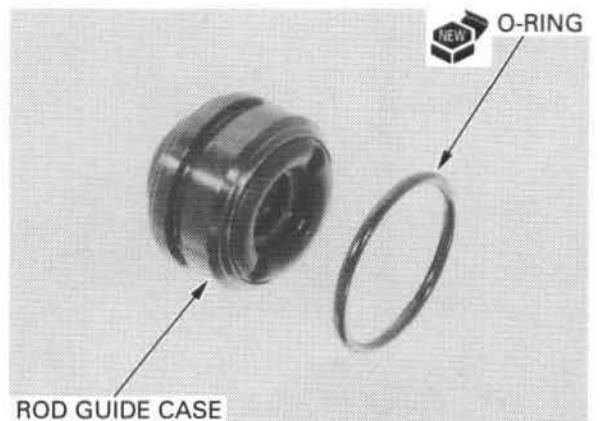

DAMPER ROD INSPECTION

Inspect the damper rod sliding surface for damage or distortion.

DAMPER ASSEMBLY

Before assembly, wash all parts with solvent and blow them dry with compressed air. Be sure that there is no dust or lint on any of the parts.

NOTE:

Never assemble valves which may have become dusty or otherwise contaminated during the disassembly process. Disassemble them, thoroughly clean them with solvent and blow them dry with compressed air before assembly.

CAUTION:

- Use added care to avoid getting solvent on the piston ring and O-ring.
- The valve arrangement and number of valves may differ from those shown.

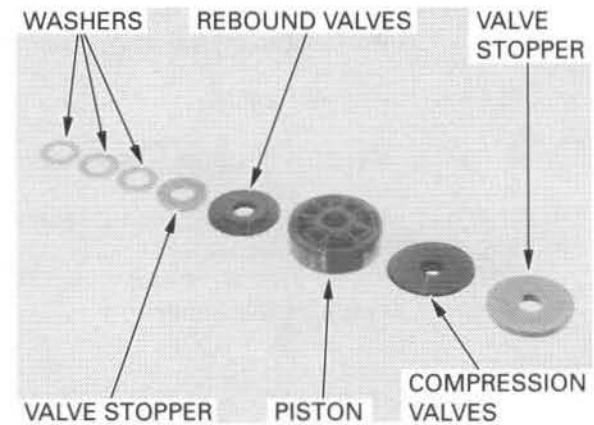
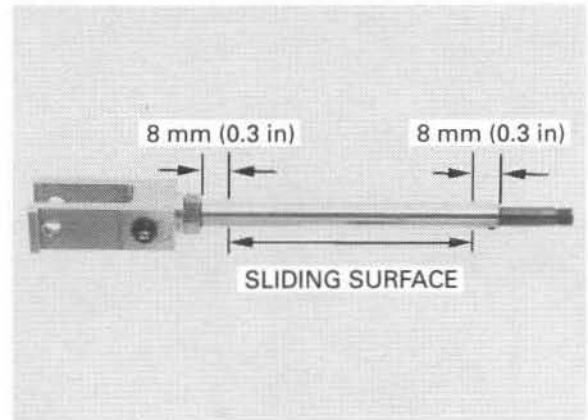

2000 - 2001:

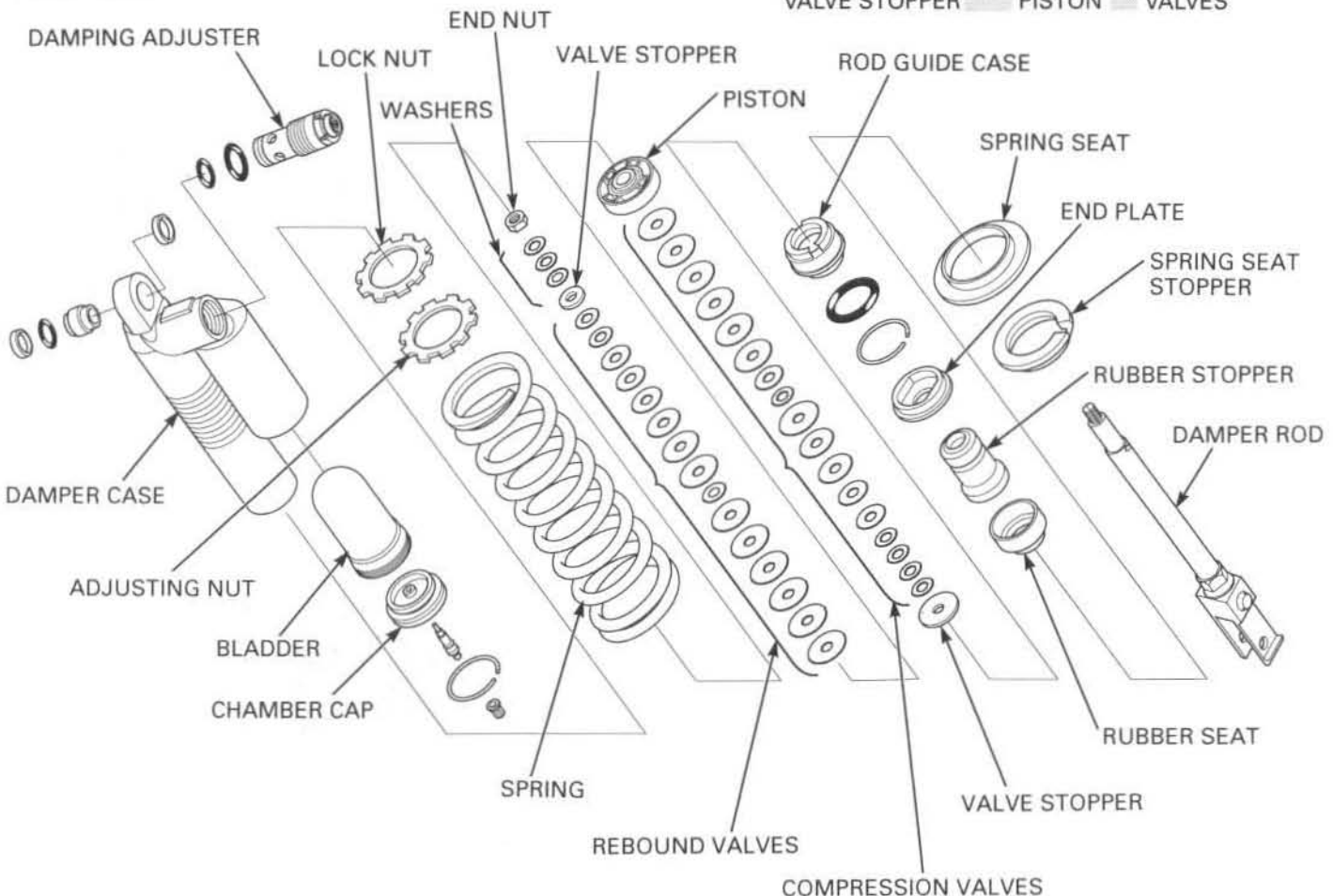

After 2001:

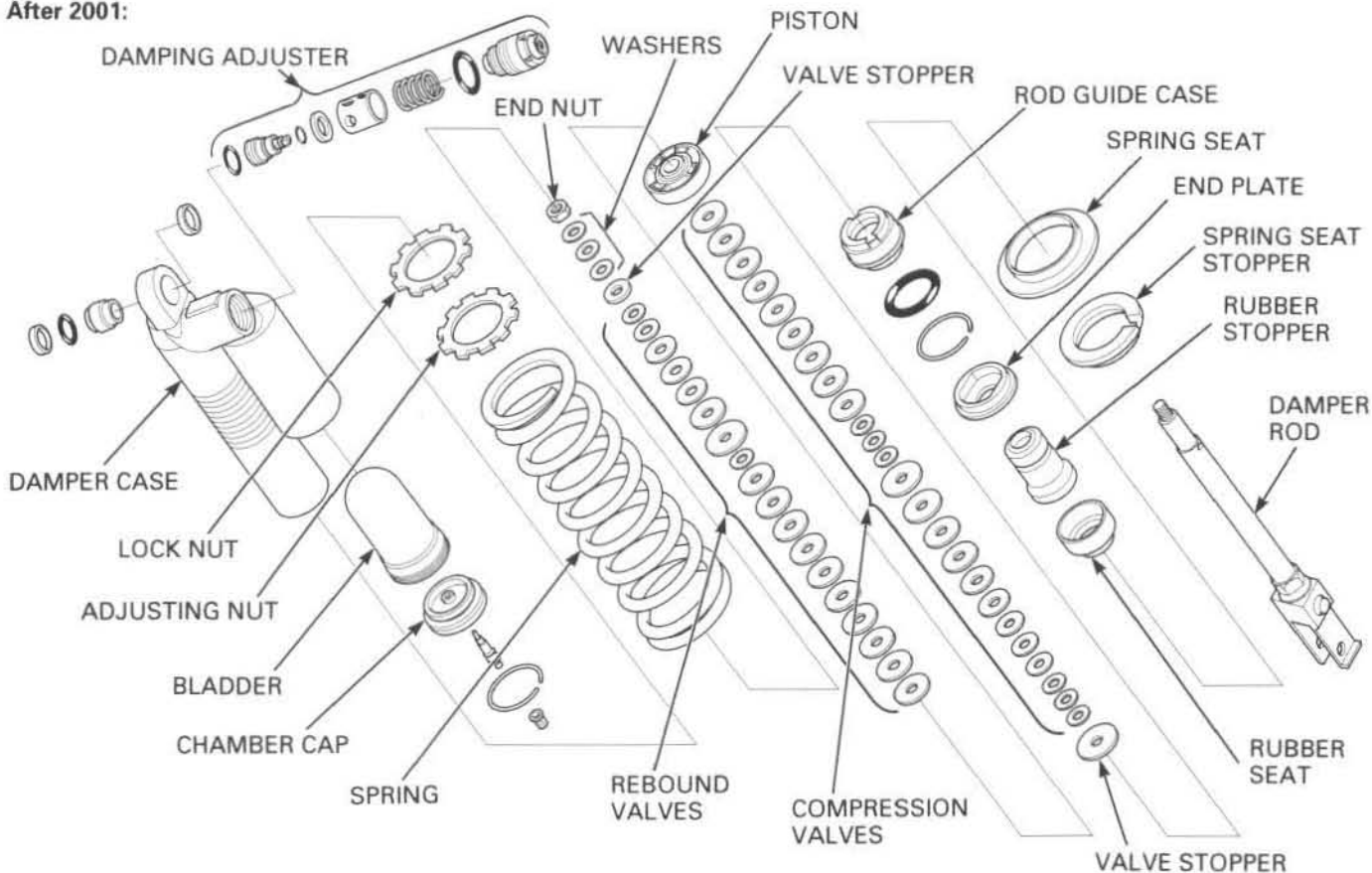

Install the rubber seat, rubber stopper and end plate.

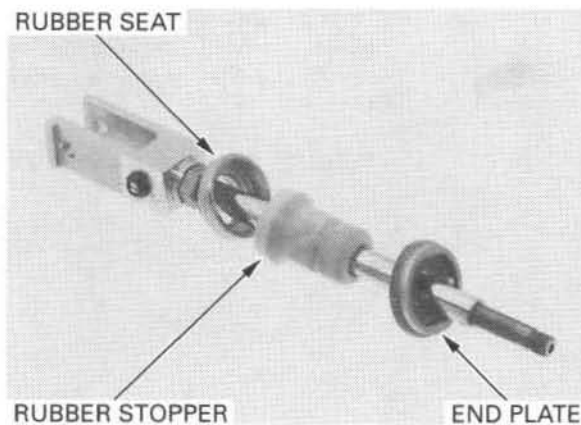

Install the special tool onto the damper rod.

TOOL:

Slider guide, 16 mm

07PMG - KZ40100
not available in
U.S.A.

Carefully install the rod guide case with the rebound rubber facing up, over the damper rod.

NOTE:

- The rod guide case oil seal is filled with grease.
- Be careful not to remove grease from the seal.
- Be careful not to damage the dust seal lip or turn it inside out.

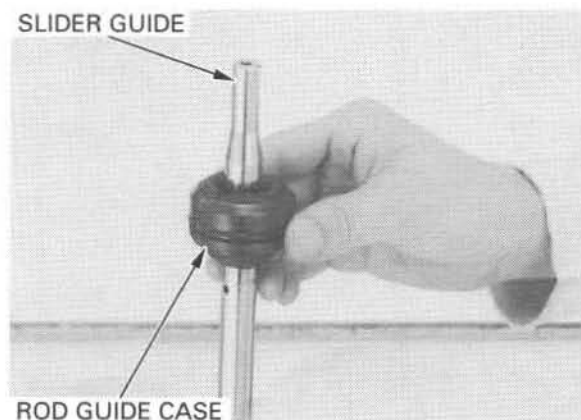

REAR WHEEL/SUSPENSION

Install the valve stopper and compression valves onto the damper rod.

NOTE:

The valve arrangement and number of valves may vary from those shown.

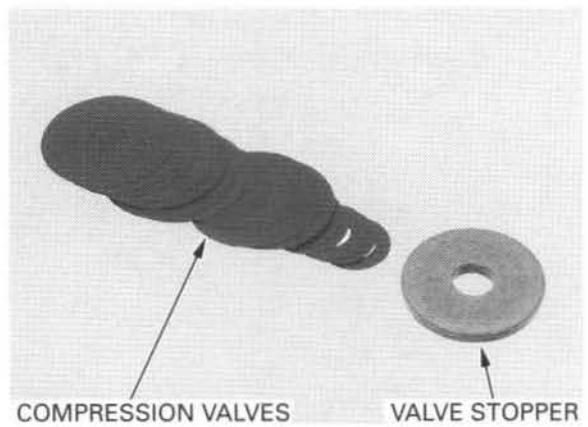

Install the piston onto the damper rod.

Install the rebound valves with their polished surfaces facing down.
Install the washers and valve stopper.

NOTE:

- Note the installation direction of the piston valves.
- Be careful not to bind the valves when installing the piston onto the damper rod. Also, check that they are concentric with the damper rod.

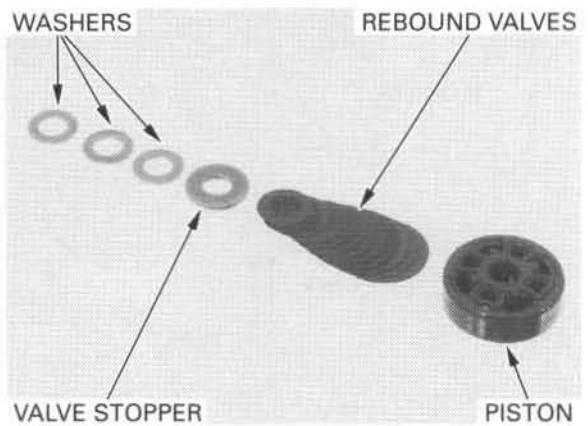

Hold the lower shock mount in a vise with soft jaws, piece of wood or shop towel.
Install and tighten a new end nut to the specified torque.

TORQUE: 37 N•m (3.8 kgf•m, 27 lbf•ft)

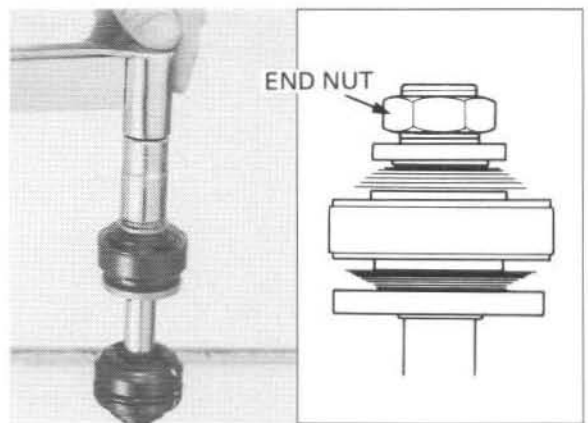

Stake the end of damper rod in three places as shown to secure the end nut.

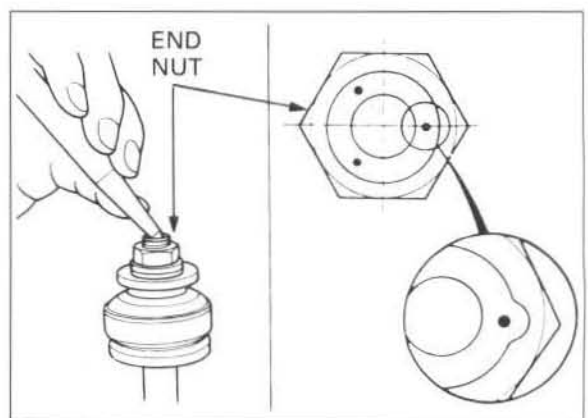

Coat the damper rod with Pro-Honda HP Fork Oil 5W or equivalent. Check the rod guide case by sliding it up and down fully to be sure there is no restriction.

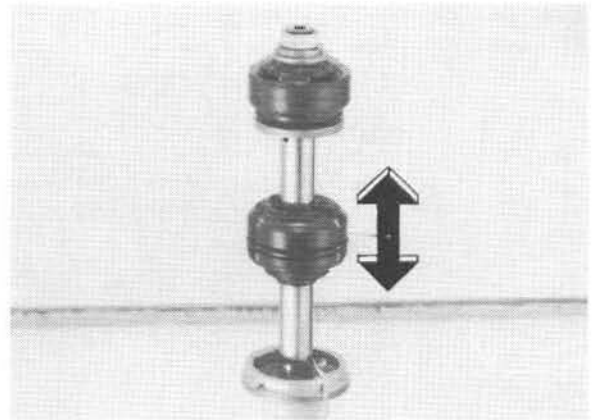

Coat the damper case inner surface, piston ring and O-ring with Pro-Honda HP Fork Oil 5W or equivalent, and insert the damper rod assembly carefully. Install the stop ring into the groove in the damper case.

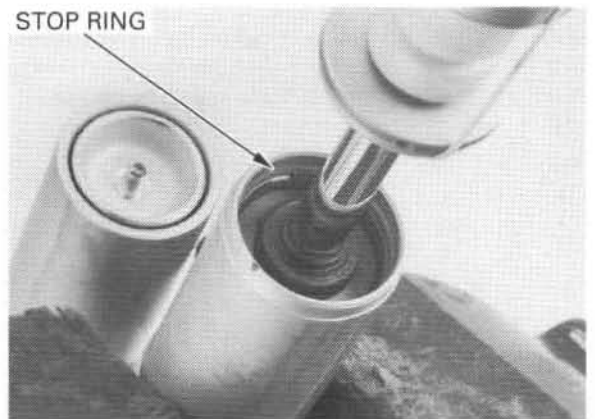

NOTE:

After assembling, check that the stop ring is seated in the groove of the damper case completely. You should not be able to pull it out of the damper case.

Hold the shock absorber gently in a vise by the damper case, protected on both sides by pieces of wood.

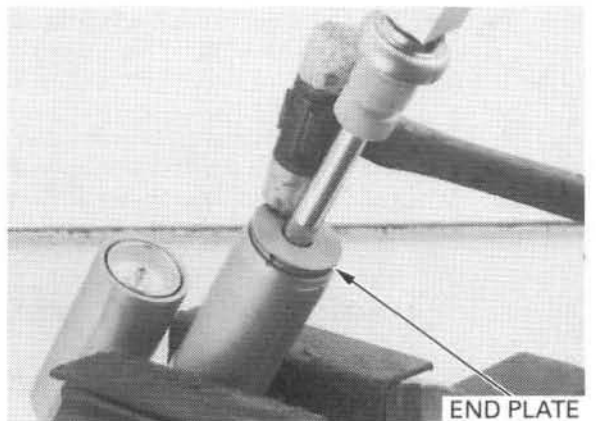

CAUTION:

Do not overtighten the vise and distort the damper case.

Drive the end plate squarely and evenly into the damper case with a plastic hammer.

Fill the damper case and reservoir with Pro-Honda HP Fork Oil 5W through the damping adjuster hole.

RECOMMENDED SHOCK OIL:

Pro-Honda HP Fork Oil 5W or equivalent

Slowly pump the damper rod until there are no bubbles in the oil that overflows from the damper case.

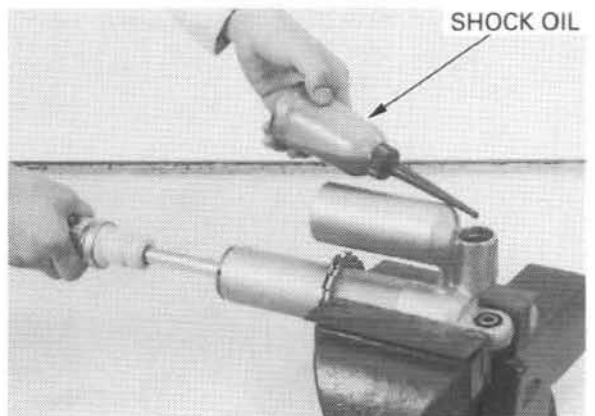

NOTE:

Make sure the rod guide case is seated against the stop ring by pulling the damper rod out all the way.

Remove the damper unit from the vise.

REAR WHEEL/SUSPENSION

Do not let oil flow out of the reservoir.

Position the damper the damping adjuster hole facing up. Turn the damper unit as shown to bleed the air from the reservoir completely.

NOTE:

When bleeding air from the reservoir, be careful to hold the damper at the angles shown so the filler hole points up.

Temporarily charge the reservoir with 49 kPa (0.5 kgf/cm², 7.1 psi) of air slowly to inflate the bladder inside.

CAUTION:

- *Check for any oil that may leak out of the valve while pressurizing. Replenish oil as necessary.*
- *Be sure that the reservoir pressure is correct with an accurate pressure gauge.*

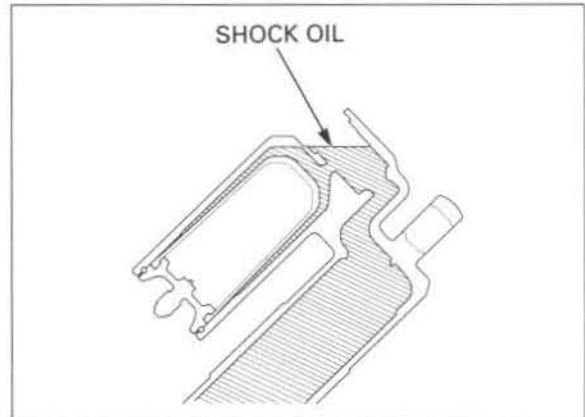

Fill the damper with the Pro-Honda HP Fork Oil 5W up to the damping adjuster hole neck. Apply oil to the new O-rings and install them to the damping adjuster. Dip the damping adjuster in clean shock oil. Slowly install the damping adjuster. Tighten the damping adjuster to the specified torque.

TOOL:

Wrench, 20 x 24 mm 07716-0020100

TORQUE: 29 N·m (3.0 kgf·m, 22 lbf·ft)

Stake the damping adjuster as shown.

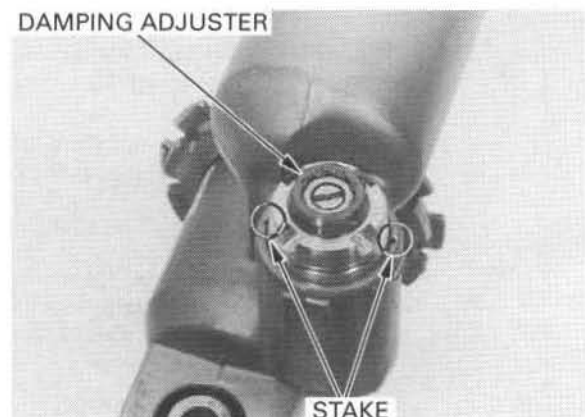
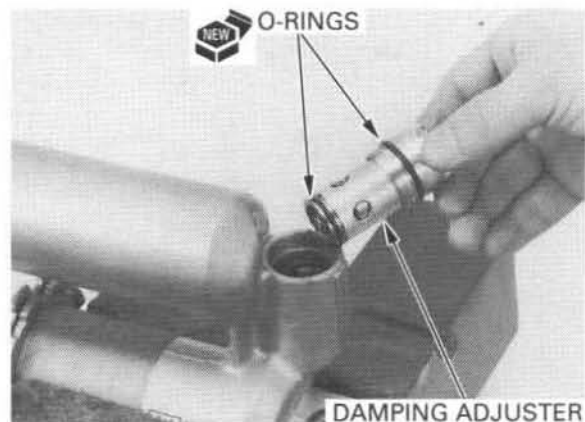

Wipe off all oil from the damper rod; oil left on the damper rod can lead to premature failure of the oil seal.

Check for oil leaks.

Release the air that was in the reservoir at precompression. Fill the reservoir with 981 kPa (10.0 kgf/cm², 142 psi) of nitrogen gas.

⚠ WARNING

The shock absorber is fitted with a gas-filled reservoir. Use only nitrogen gas to pressurize the shock absorber. The use of an unstable gas can cause a fire or explosion resulting in serious injury.

Install the valve cap.

Install the spring (with the wider end sliding against the adjusting nut), spring seat and spring seat stopper.

Temporarily tighten the adjusting nut and lock nut.

Turn the shock absorber lower mount so that the rebound adjuster screw is on the same side of the shock as the reservoir as shown.

Turn the spring adjusting nut until the spring length measurement recorded at disassembly is reached or until the spring length is as specified below.

NOTE:

One turn of the adjusting nut changes the spring length by 1.5 mm (0.06 in).

STANDARD SPRING LENGTH:

2000: 265 mm (10.4 in)

After 2000: 267 mm (10.5 in)

Hold the adjusting nut and tighten the lock nut.

TORQUE: 29 N·m (3.0 kgf·m, 22 lbf·ft)

Use this standard spring length as a baseline. See the Owner's Manual for detailed instructions on adjusting preload and damping setting for rider weight and setting damping for riding conditions and rider skill.

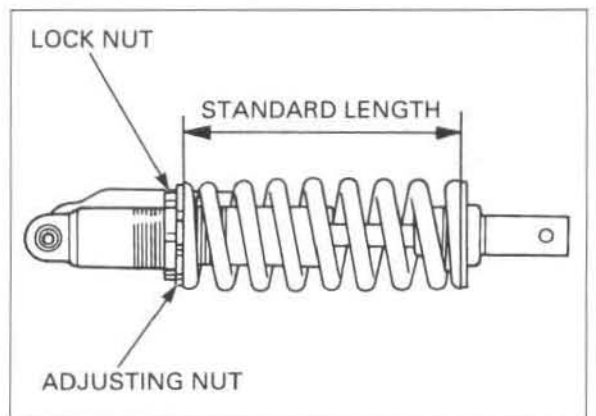
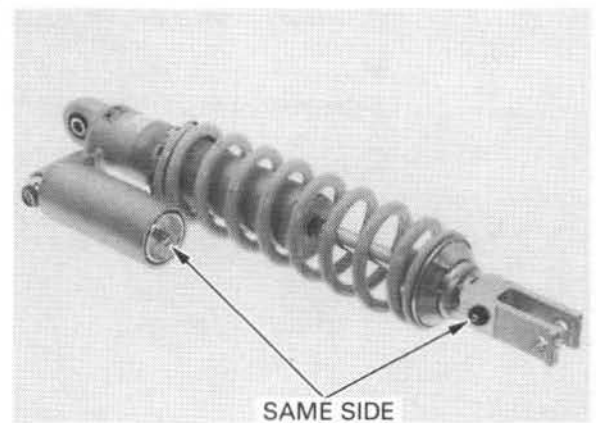
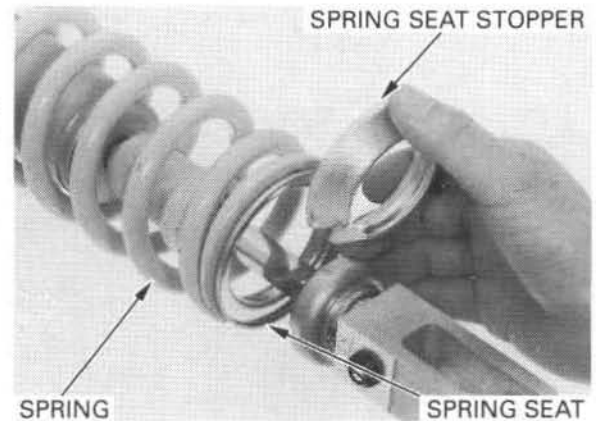
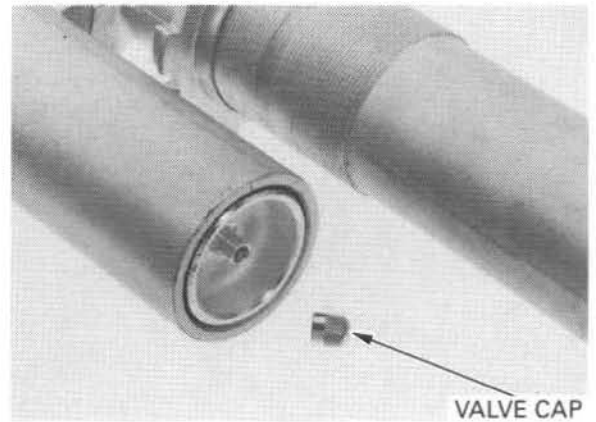

REAR WHEEL/SUSPENSION

SPHERICAL BEARING REPLACEMENT

Check the spherical bearing for wear or damage. If it is worn or damaged, it must be replaced.

Remove the dust seals.

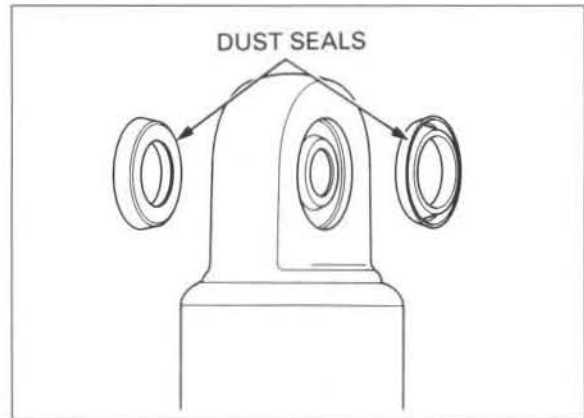

Press the spherical bearing to get the clearance necessary to remove the stop ring.

TOOL:
Spherical bearing driver 07946-KA30200 Not available in U.S.A.

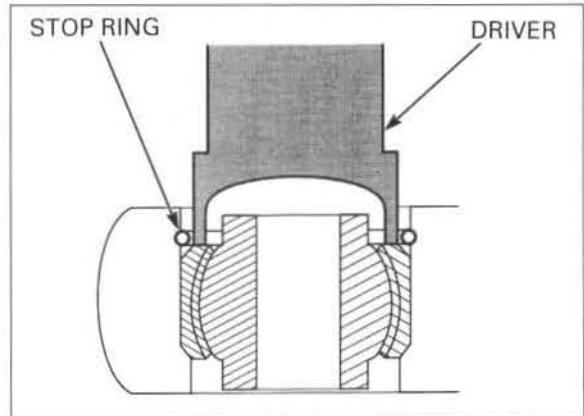

Press the spherical bearing out of the upper mount.

TOOL:
Spherical bearing driver 07946-KA30200

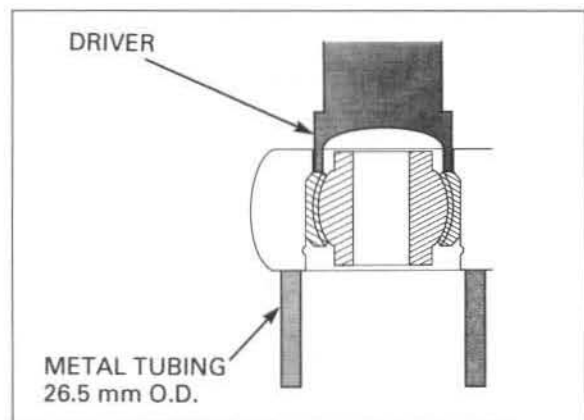

Apply multi-purpose grease NLGI No. 2 (Molybdenum disulfide MoS₂ additive) to the new spherical bearing.

Drive the bearing in evenly; do not allow it to tilt. Press a new spherical bearing into the upper mount.

TOOL:
Spherical bearing driver 07946-KA30200 Not available in U.S.A.

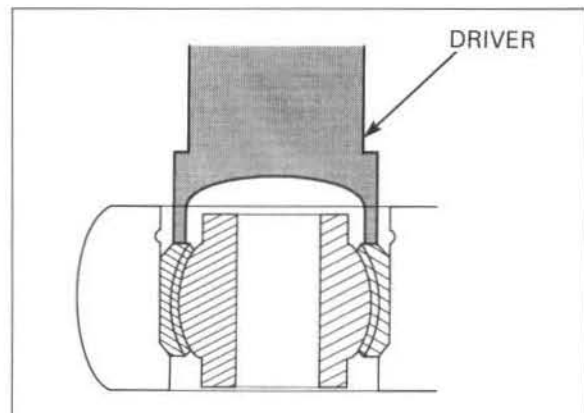

Install a new stop ring into the groove of the upper mount securely.
 Press the spherical bearing into the upper mount until it seats against the stop ring.

TOOL:
Spherical bearing driver 07946-KA30200 Not available in U.S.A.

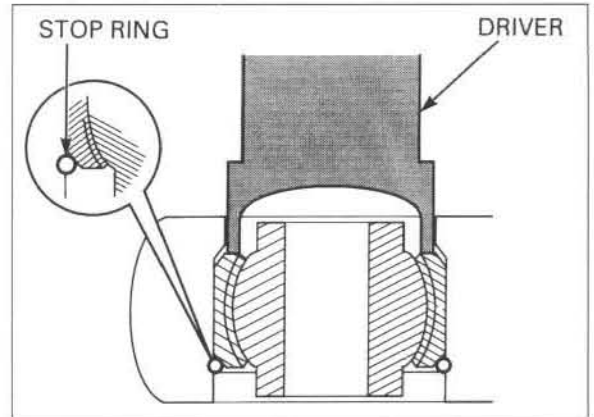

Be sure to install the correct dust seal in each side. Apply grease to the lip of the new dust seals and install them.



INSTALLATION

Set the shock absorber onto the shock arm with the rebound adjuster facing to the right.
 Install the lower mounting bolt by aligning the cut-out of the bolt with the stopper on the shock absorber.

Install and tighten the lower mounting nut.

TORQUE: 44 N•m (4.5 kgf•m, 33 lbf•ft)

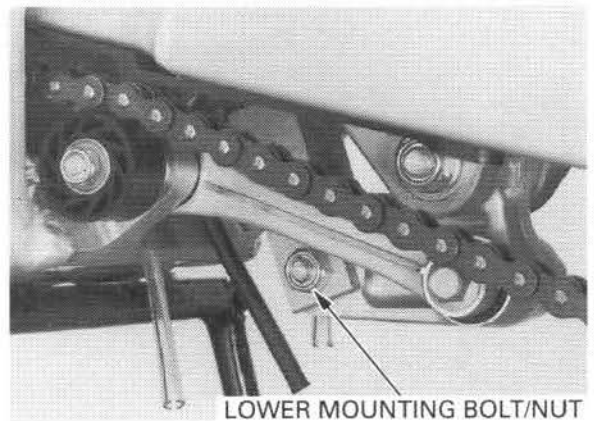

Install and tighten the shock absorber upper mounting nut/bolt.

TORQUE: 44 N•m (4.5 kgf•m, 33 lbf•ft)

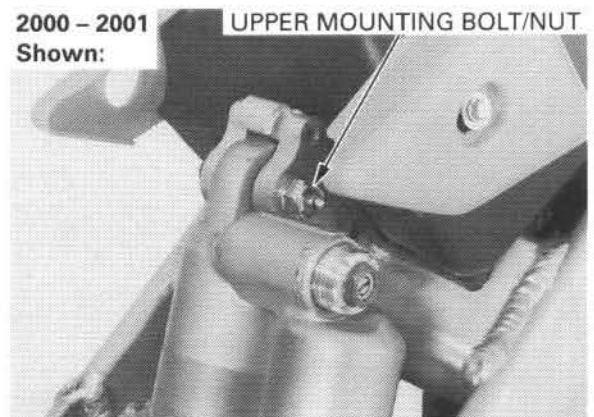

REAR WHEEL/SUSPENSION

Install the sub-frame (page 2-4).

After 2001 Shown:

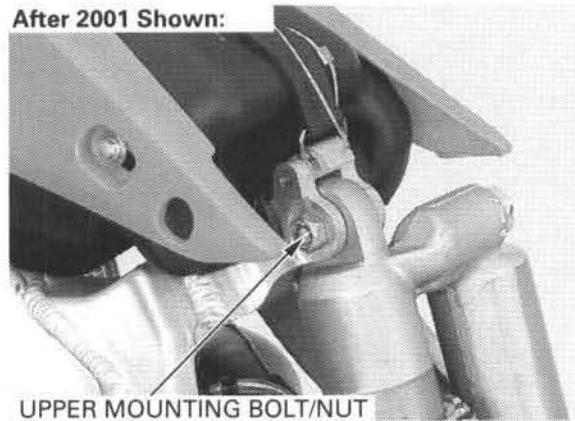

SHOCK LINKAGE

REMOVAL

Remove the bolt and drive chain roller.

2000 - 2001 Shown:

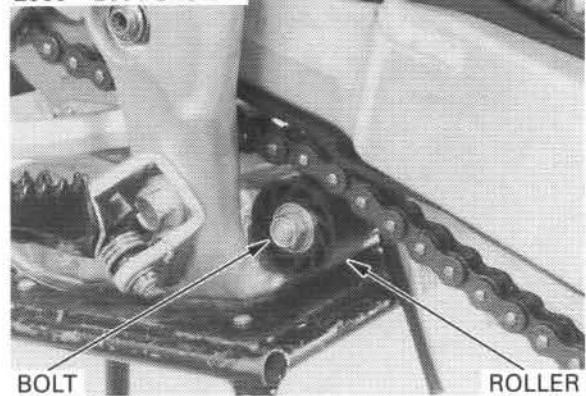

Remove the following:

- Shock absorber lower mounting bolt/nut
- Shock arm bolt/nut (shock link side)
- Shock arm bolt/nut (swingarm side)
- Shock arm
- Shock link bolt/nut (frame side)
- Shock link

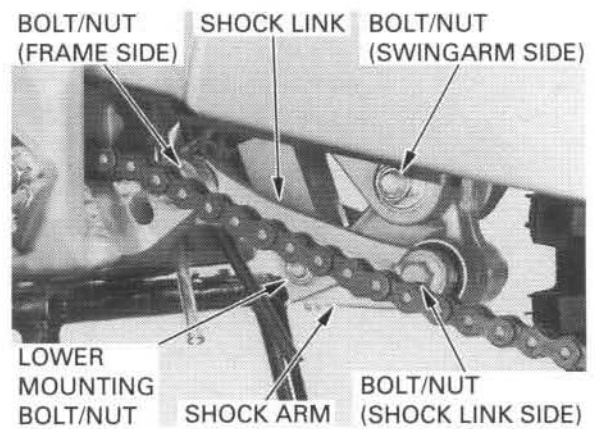

Remove the side collars, pivot collar and dust seals from the shock link.

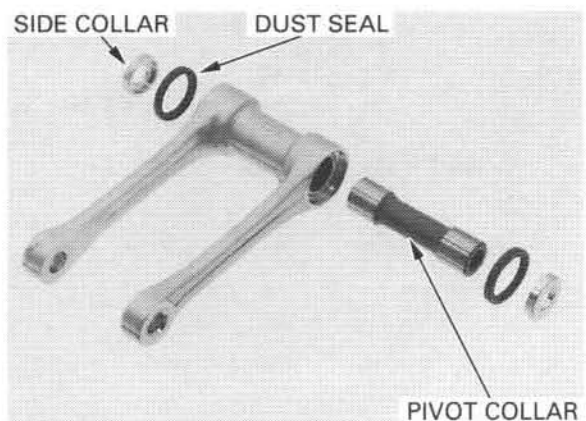

Remove the pivot collars and side collars from the shock arm (swingarm side, shock link side).

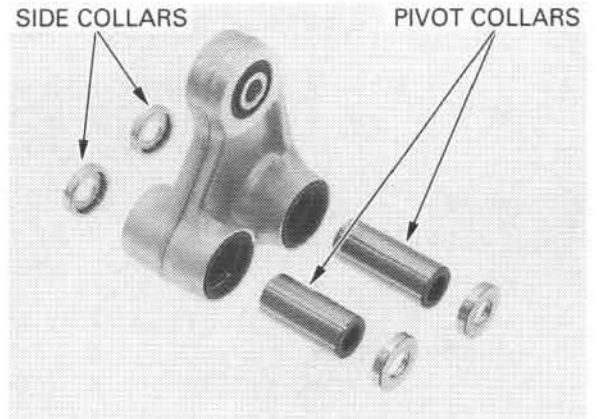

Remove the dust seals and washers (swingarm side, shock link side).

Remove the dust seals, side collars and pivot collar (shock absorber side).

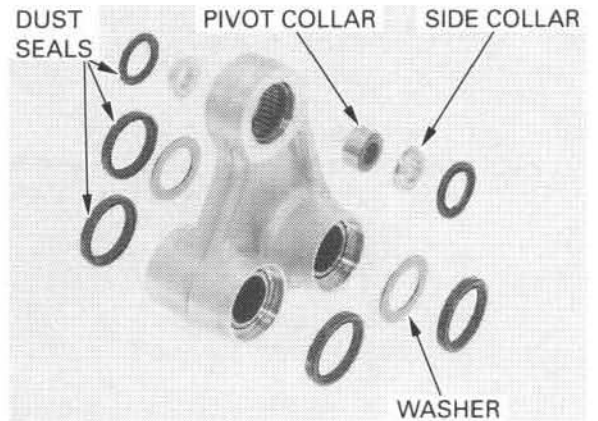

INSPECTION

Check the dust seals and collars for wear, damage or fatigue.
Check the needle bearings for damage or loose fit.
Check the shock arm and shock link for cracks or damage.

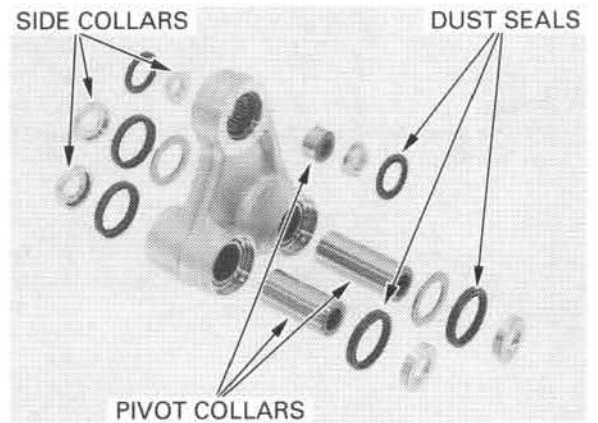

If the needle bearings are damaged, replace them.

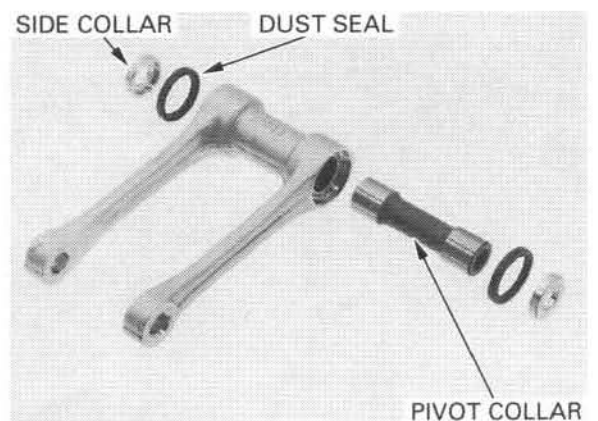

BEARING REPLACEMENT

SHOCK ARM NEEDLE BEARING

Press the needle bearings (shock link side, swingarm side) out of the shock arm using special tools and a hydraulic press.

TOOLS:

SHOCK LINK SIDE AND SWINGARM SIDE:

Driver	07949 - 3710001
Attachment, 24 x 26 mm	07746 - 0010700
Pilot, 20 mm	07746 - 0040500
Attachment, 30 mm I.D.	07746 - 0030300

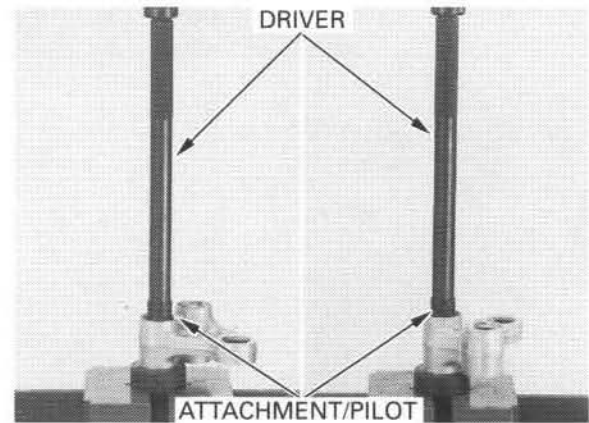

Press the needle bearing (shock absorber side) out of the shock arm using special tools and a hydraulic press.

TOOLS:

Driver	07749 - 0010000
Attachment, 24 x 26 mm	07746 - 0010700
Pilot, 17 mm	07746 - 0040400
Attachment, 30 mm I.D.	07746 - 0030300

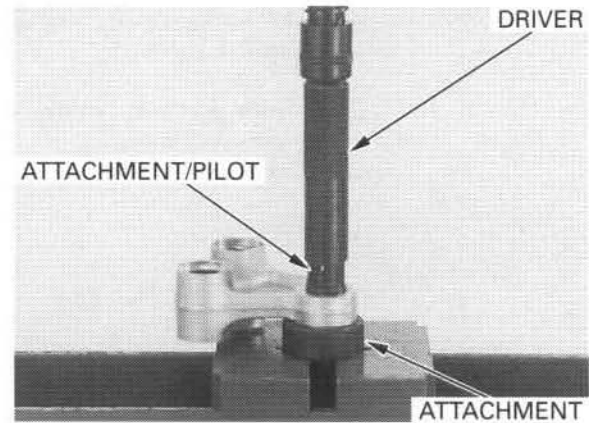

Press the needle bearings into the shock arm with the marked side facing out.

Pack the new needle bearings with multi-purpose grease.

Press the new needle bearings into the shock link side pivot so that the needle bearing surface is lower 6.5 - 7.0 mm (0.26 - 0.28 in) from the end of the shock arm surface.

TOOLS:

Driver	07749 - 0010000
Attachment, 24 x 26 mm	07746 - 0010700
Pilot, 20 mm	07746 - 0040500

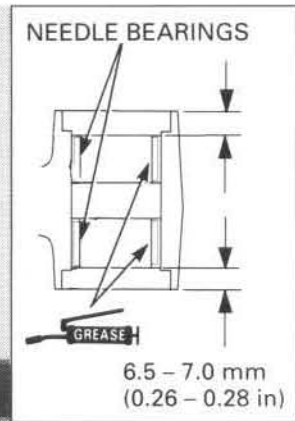
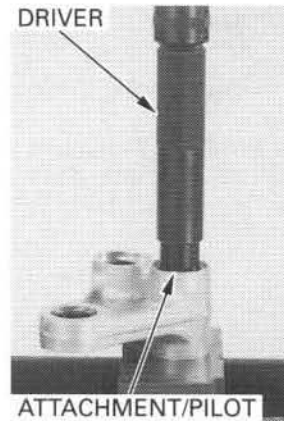

Press the needle bearings into the shock arm with the marked side facing out.

Pack the new needle bearing with multi-purpose grease.

Press the new needle bearings into the swingarm side pivot so that the needle bearing surface is lower 4.4 - 4.7 mm (0.17 - 0.19 in) from the end of the shock arm surface.

TOOLS:

Driver	07749 - 0010000
Attachment, 24 x 26 mm	07746 - 0010700
Pilot, 20 mm	07746 - 0040500

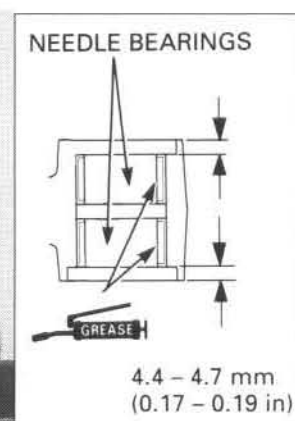
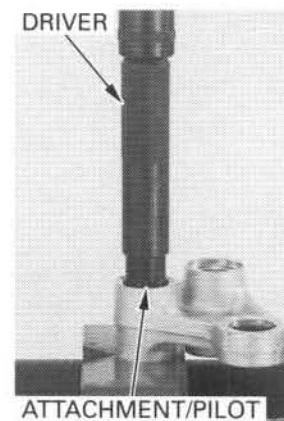

Press the needle bearing into the shock arm with the marked side facing out.

Pack a new needle bearing with multi-purpose grease.
Press a new needle bearing into the shock absorber side pivot so that the needle bearing surface is lower 2.0 – 2.2 mm (0.08 – 0.09 in) from the end of the shock arm surface.

TOOLS:

- Driver** 07749 – 0010000
- Attachment, 24 x 26 mm** 07746 – 0010700
- Pilot, 19 mm** 07746 – 0041400

SHOCK LINK NEEDLE BEARING

Drive the needle bearings out of the shock link from the opposite side using a suitable tool.

Press the needle bearings into the shock link with the marked side facing out.

Pack the new needle bearings with multi-purpose grease.
Press the new needle bearings into the shock link pivot so that the needle bearing surface is lower 4.4 – 4.7 mm (0.17 – 0.19 in) from the end of the shock link surface.

TOOLS:

- Driver** 07749 – 0010000
- Attachment, 28 x 30 mm** 07946 – 1870100
- Pilot, 20 mm** 07746 – 0040500

INSTALLATION

Apply multi-purpose grease NLGI No. 2 (molybdenum disulfide additive) to the shock arm, shock link dust seal lips, collars and bearings.

NOTE:

Make sure that the needle bearing rollers are in position before installing.
Number of needle rollers :
Shock link: 32
Shock arm: shock link side : 32
 swingarm side : 32
 shock absorber side : 27

Install the dust seals, pivot collar and side collars to the shock link.

Install the dust seals and washers to the shock arm (shock link side).

Install the dust seals to the shock arm (swingarm side).

Install the pivot collar, side collars and dust seals to the shock arm (shock absorber side).

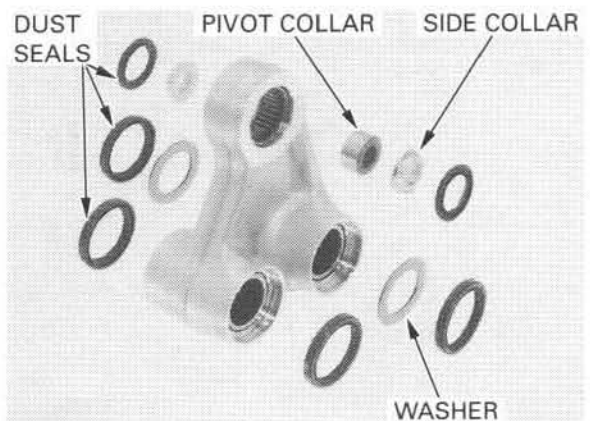
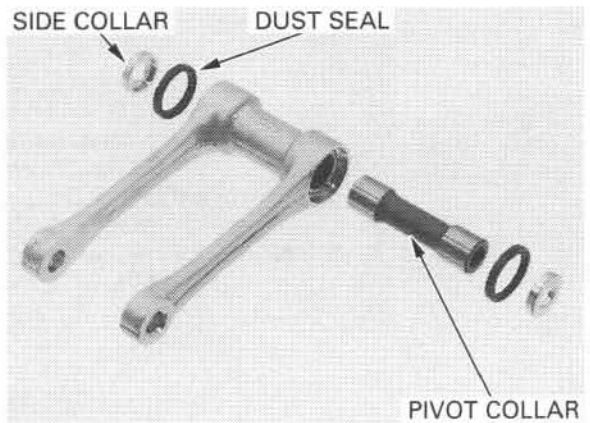
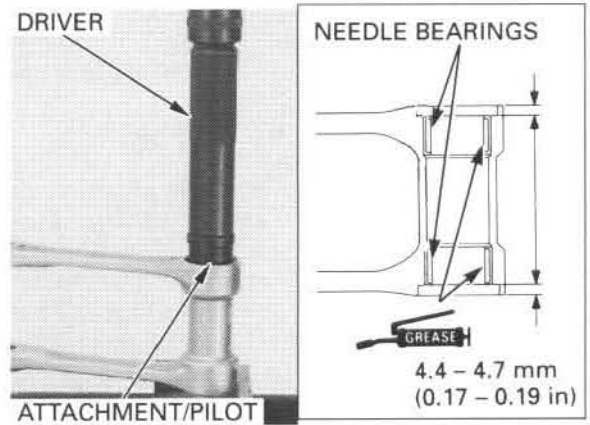
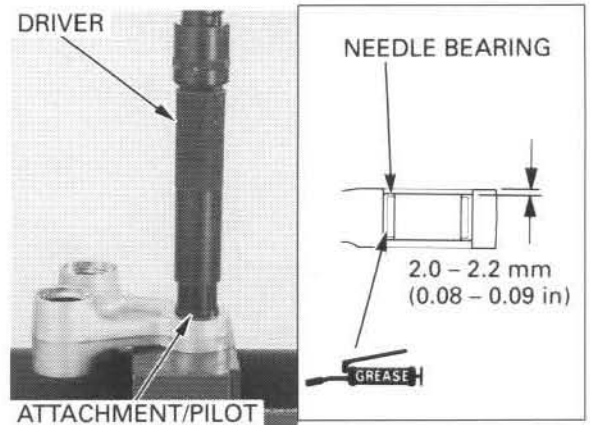

REAR WHEEL/SUSPENSION

Install the pivot collars and side callars to the shock arm (swingarm side, shock link side).

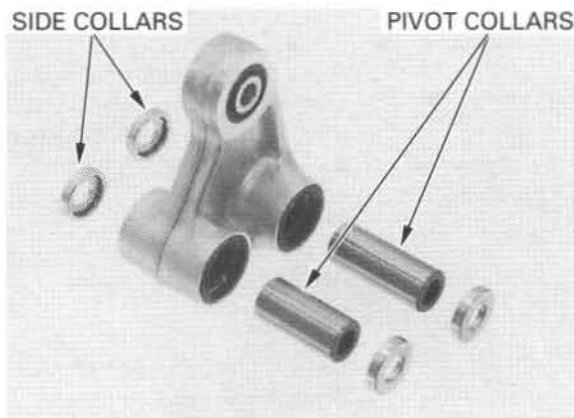

Apply oil to the shock arm nut threads and flange surface.

Temporarily install the following:

- Shock link
- Shock link bolt/nut
- Shock arm
- Shock arm bolt/nut (swingarm side)
- Shock arm bolt/nut (shock link side)

Install the lower mounting bolt by aligning the cut out of the bolt with the stopper on the shock absorber.

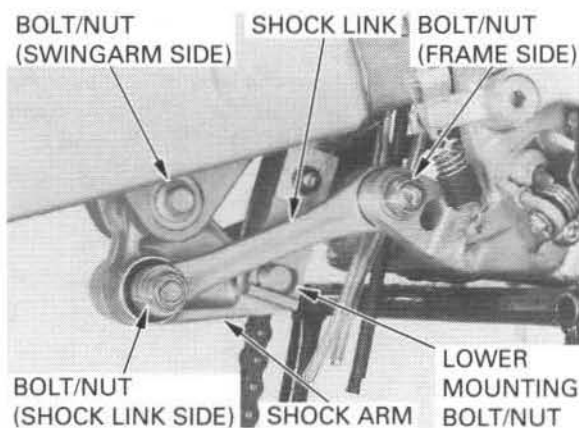

Tighten all nuts to the specified torque.

TORQUE:

- Shock link nut: 78 N•m (8.0 kgf•m, 58 lbf•ft)
- Shock arm nut (swingarm side):
78 N•m (8.0 kgf•m, 58 lbf•ft)
- Shock arm nut (shock link side):
78 N•m (8.0 kgf•m, 58 lbf•ft)
- Shock absorber lower mounting nut:
44 N•m (4.5 kgf•m, 33 lbf•ft)

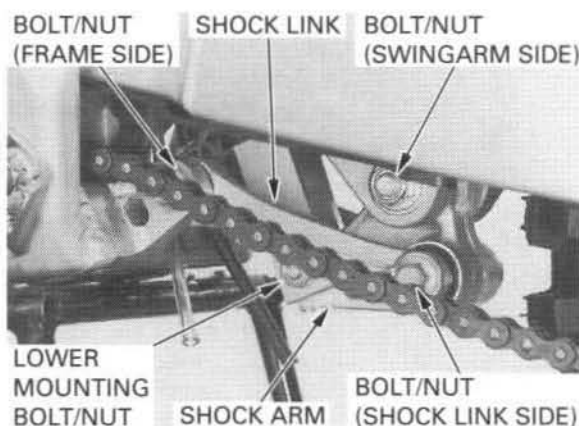

2000 - 2001:
Install the drive chain roller with its
"→" mark side
facing out.

Install the drive chain roller and tighten the bolt to the specified torque.

TORQUE:

- 2000: 22 N•m (2.2 kgf•m, 16 lbf•ft)
- After 2000: 12 N•m (1.2 kgf•m, 9 lbf•ft)

2000 - 2001 Shown:

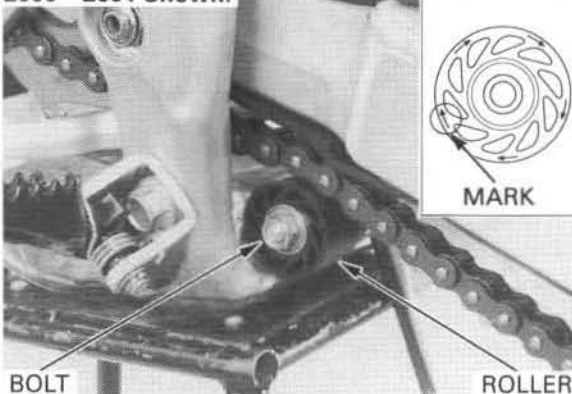

SWINGARM

REMOVAL

Raise the rear wheel off the ground by placing a work-stand under the engine.

Remove the rear wheel (page 12-4).

After 2001: Remove the brake pedal (page 13-22).

Remove the shock arm bolt and nut (swingarm side).

2000 – 2001: Remove the screws and brake hose guides.

After 2001: Remove the screw and brake hose guide.

Remove the rear brake caliper from the slide rail on the swingarm.

CAUTION:

- Do not disconnect the hydraulic line.
- Do not suspend the brake caliper from the brake hose.

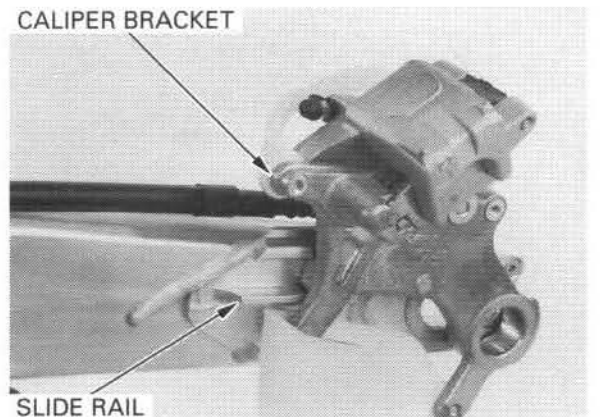
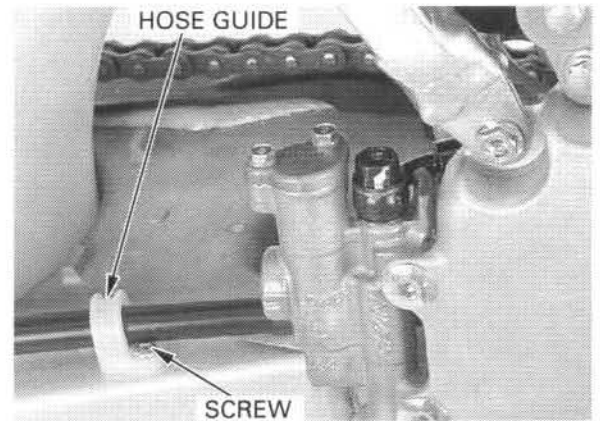
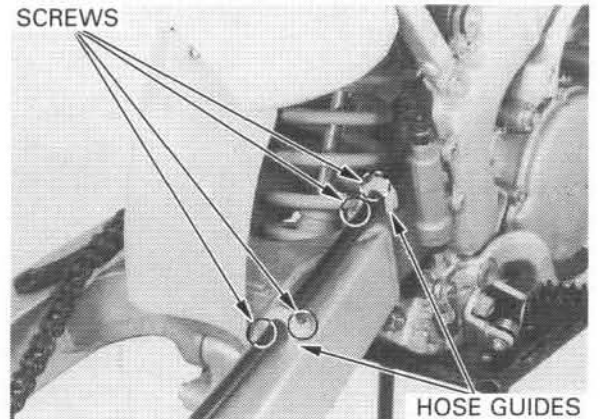
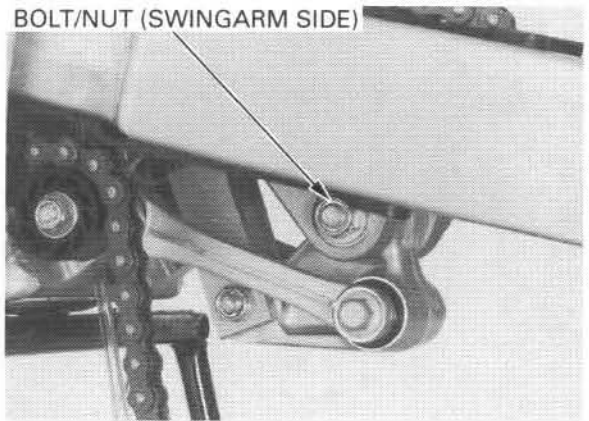

REAR WHEEL/SUSPENSION

Remove the swingarm pivot nut.

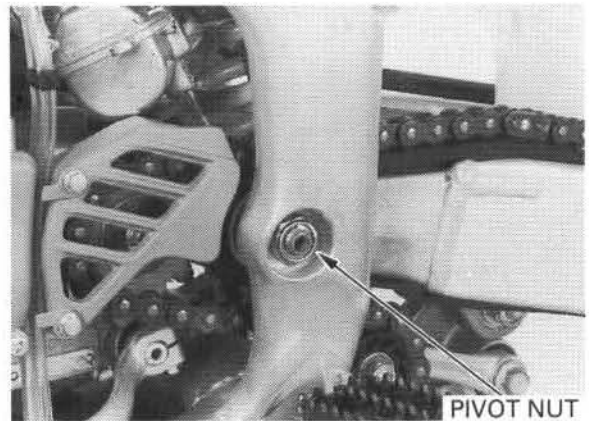

Remove the swingarm pivot bolt and swingarm.

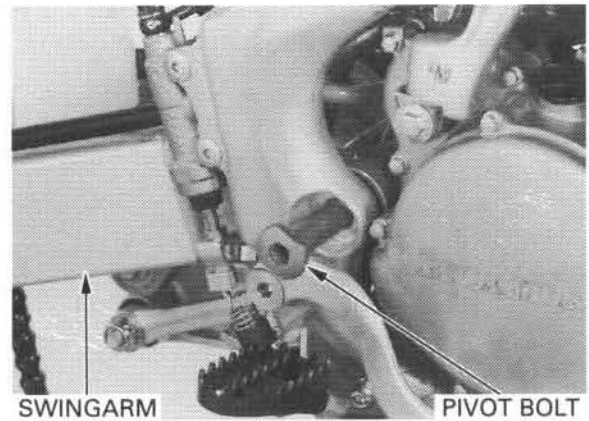

Check the chain slider and chain guide for wear or damage (page 3-12).

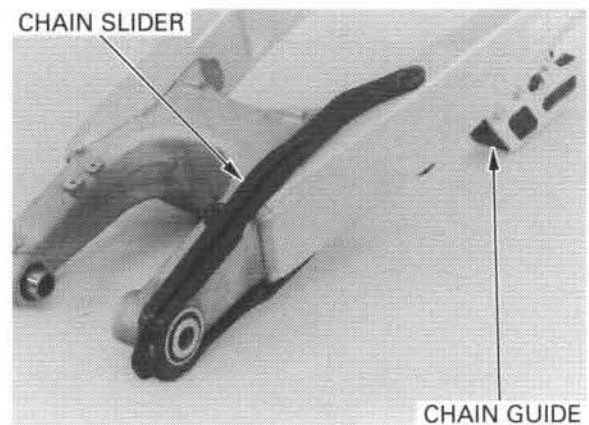

DISASSEMBLY

Remove the bolts, nuts and chain guide.
Remove the screws and chain slider.

Remove the following:

- Side collars
- Dust seals
- Washers
- Thrust needle bearings
- Collars

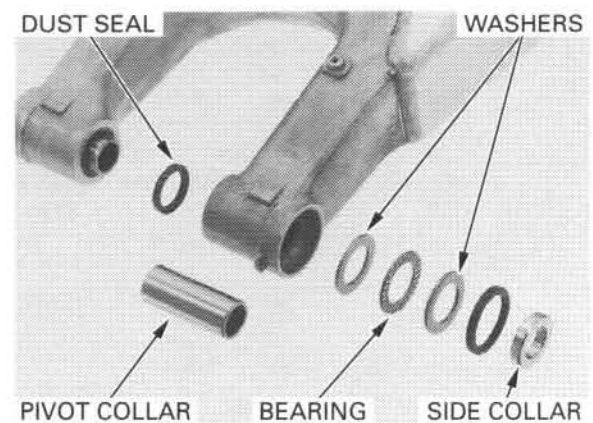

Check the dust seals and collars for wear, damage or fatigue.
 Check the needle bearings and thrust needle bearings for damage or loose fit.
 Check the swingarm for cracks or damage.

Replace them, if necessary.

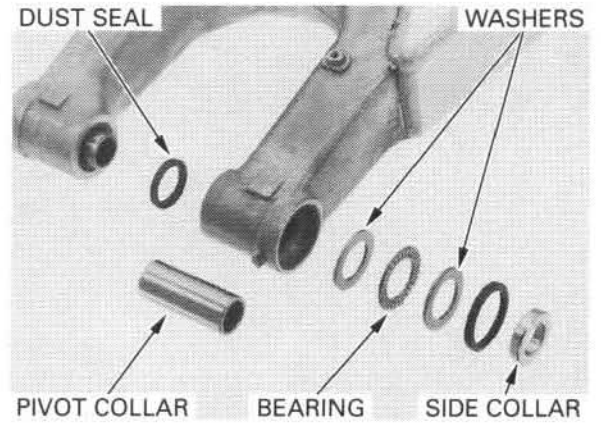

BEARING REPLACEMENT

Press the needle bearings out of the swingarm using special tools and a hydraulic press.

TOOLS:

- | | |
|-------------------------------|------------------------|
| Driver | 07949 - 3710001 |
| Attachment, 24 x 26 mm | 07746 - 0010700 |
| Pilot, 22 mm | 07746 - 0041000 |
| Attachment, 30 mm I.D. | 07746 - 0030300 |

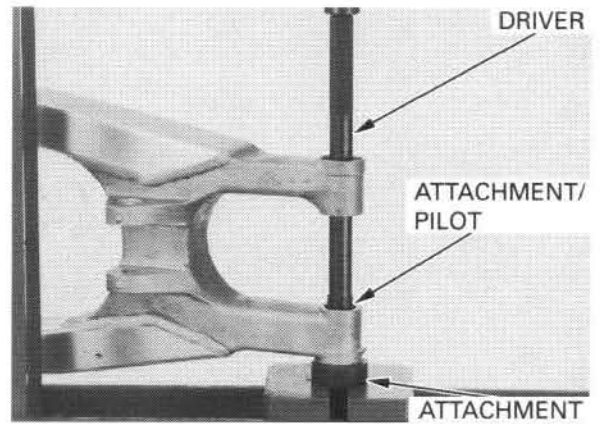

Pack the new needle bearings with multi-purpose grease.
 Press the new needle bearings into the swingarm using the special tools as shown.

Press the needle bearings into the swingarm with the marked side facing out.

TOOLS:

- | | |
|-------------------------------|------------------------|
| Driver | 07749 - 0010000 |
| Attachment, 28 x 30 mm | 07746 - 1870100 |
| Pilot, 22 mm | 07746 - 0041000 |

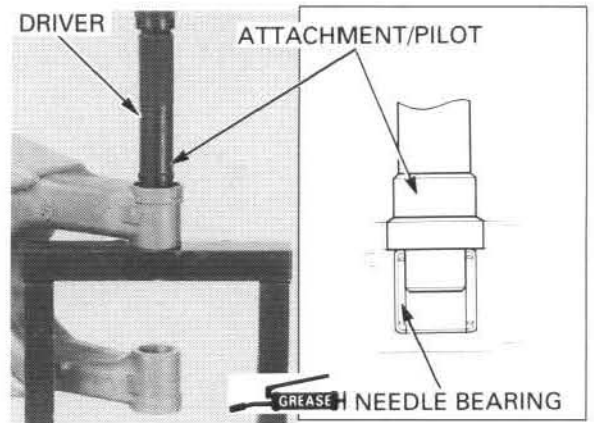

REAR WHEEL/SUSPENSION

ASSEMBLY

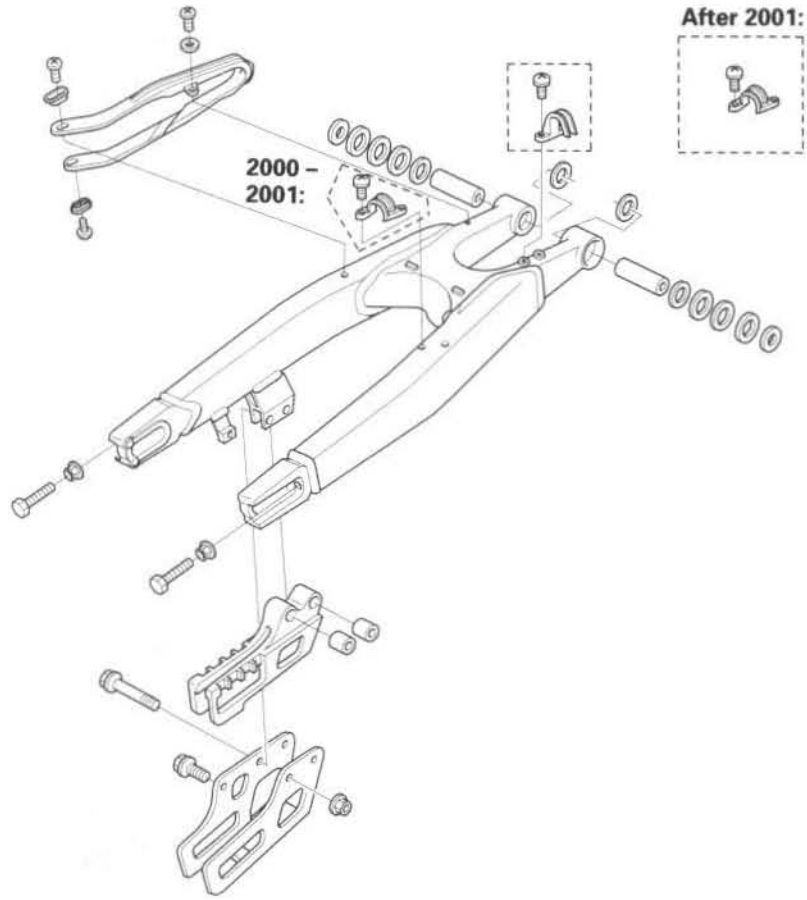

Install the following:

- Washers
- Thrust needle bearings
- Dust seals
- Collars
- Side collars

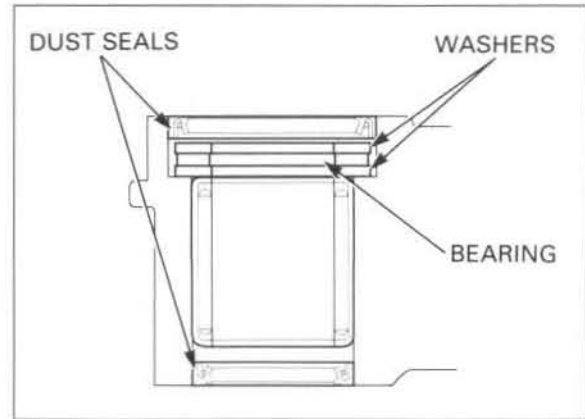

Install the chain slider with its hole and tab on the swingarm.

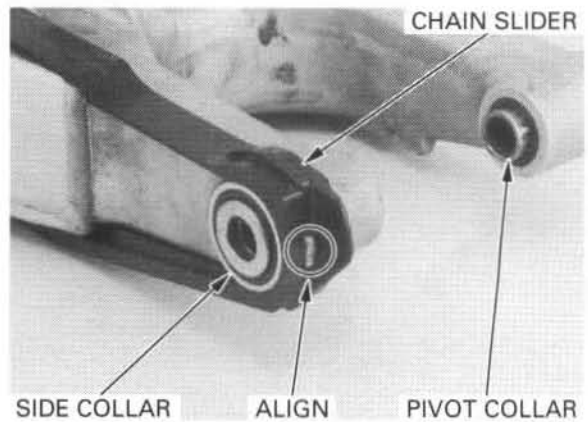

Clean and apply a locking agent to the rearside screw threads.
Install and tighten the screws to the specified torque.

TORQUE: 4 N•m (0.4 kgf•m, 3.0 lbf•ft)

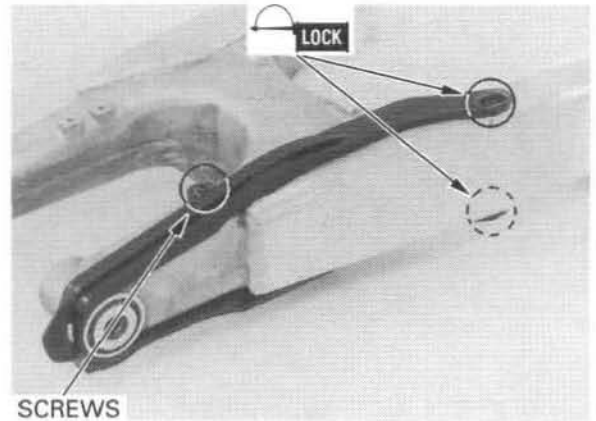

Install the chain guide.
Install and tighten the bolts and nuts to the specified torque.

TORQUE: 12 N•m (1.2 kgf•m, 9 lbf•ft)

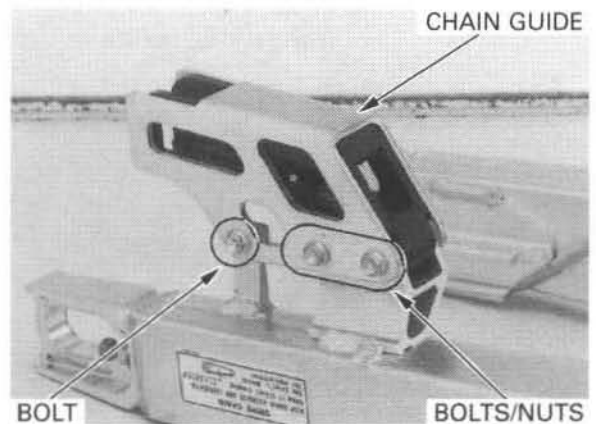

INSTALLATION

Apply thin coat of grease to the swingarm pivot bolt sliding surface.
Install the swingarm onto the frame.
Install the swingarm pivot bolt to the frame and swingarm pivot.

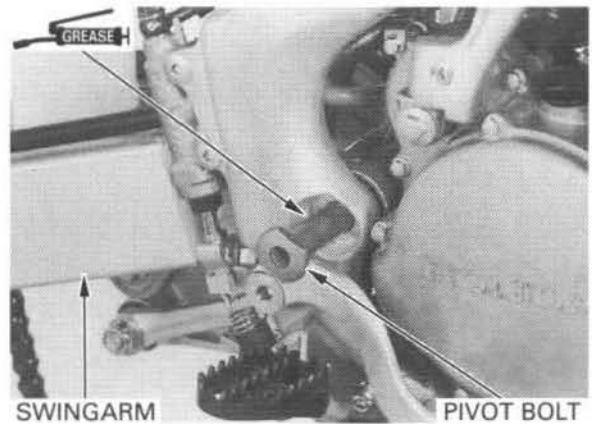

Install and tighten the swingarm pivot nut to the specified torque.

TORQUE: 88 N•m (9.0 kgf•m, 65 lbf•ft)

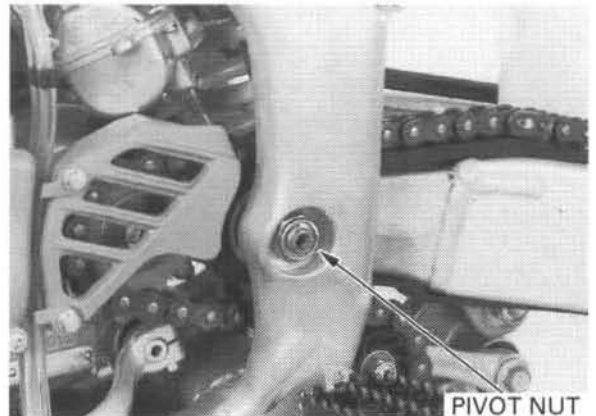

REAR WHEEL/SUSPENSION

Install the rear brake caliper to the slide rail on the swingarm.

CAUTION:

Do not twist the brake hose.

CALIPER BRACKET

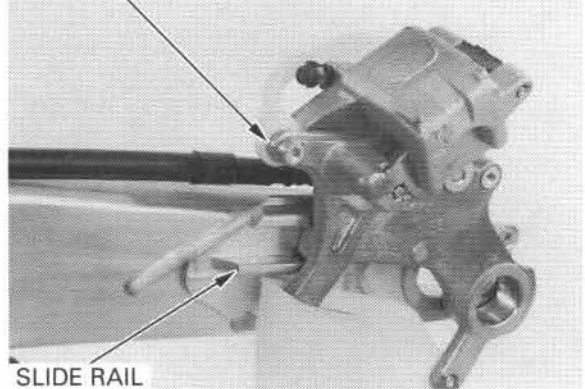

SLIDE RAIL

2000 – 2001: Install the brake hose guides. Install and tighten the screws to the specified torque.

TORQUE: 1.2 N•m (0.12 kgf•m, 0.87 lbf•ft)

2000 – 2001 Shown:
SCREWS

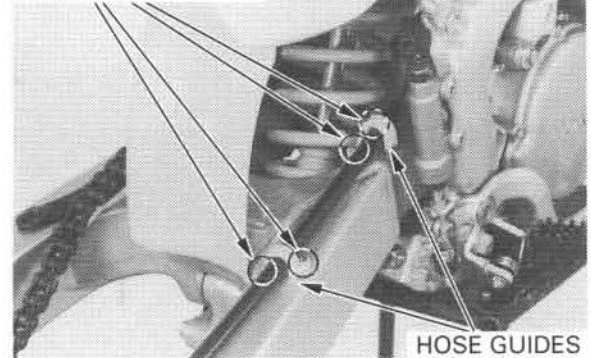

HOSE GUIDES

After 2001: Install the brake hose guide. Tighten the screw to the specified torque.

TORQUE: 1.2 N•m (0.12 kgf•m, 0.87 lbf•ft)

After 2001 Shown:
BRAKE HOSE GUIDE

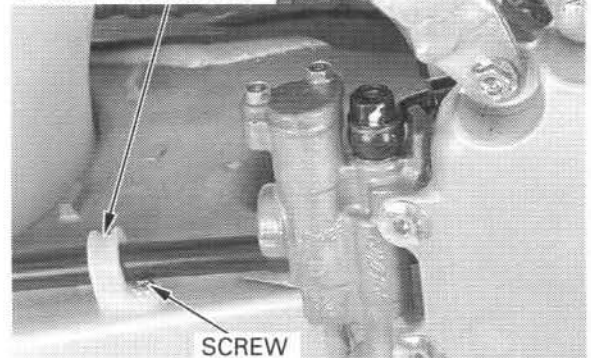

SCREW

Apply oil to the shock arm nut (swingarm side) threads and seating surface. Install the shock arm bolt and nut. Tighten the nut to the specified torque.

TORQUE: 78 N•m (8.0 kgf•m, 58 lbf•ft)

Install the rear wheel (page 12-8).

BOLT/NUT (SWINGARM SIDE)

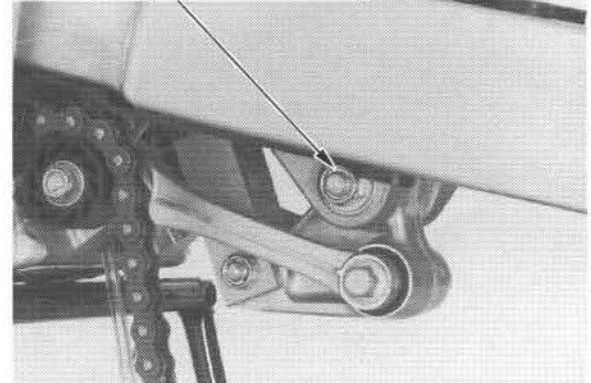

MEMO

BRAKE SYSTEM

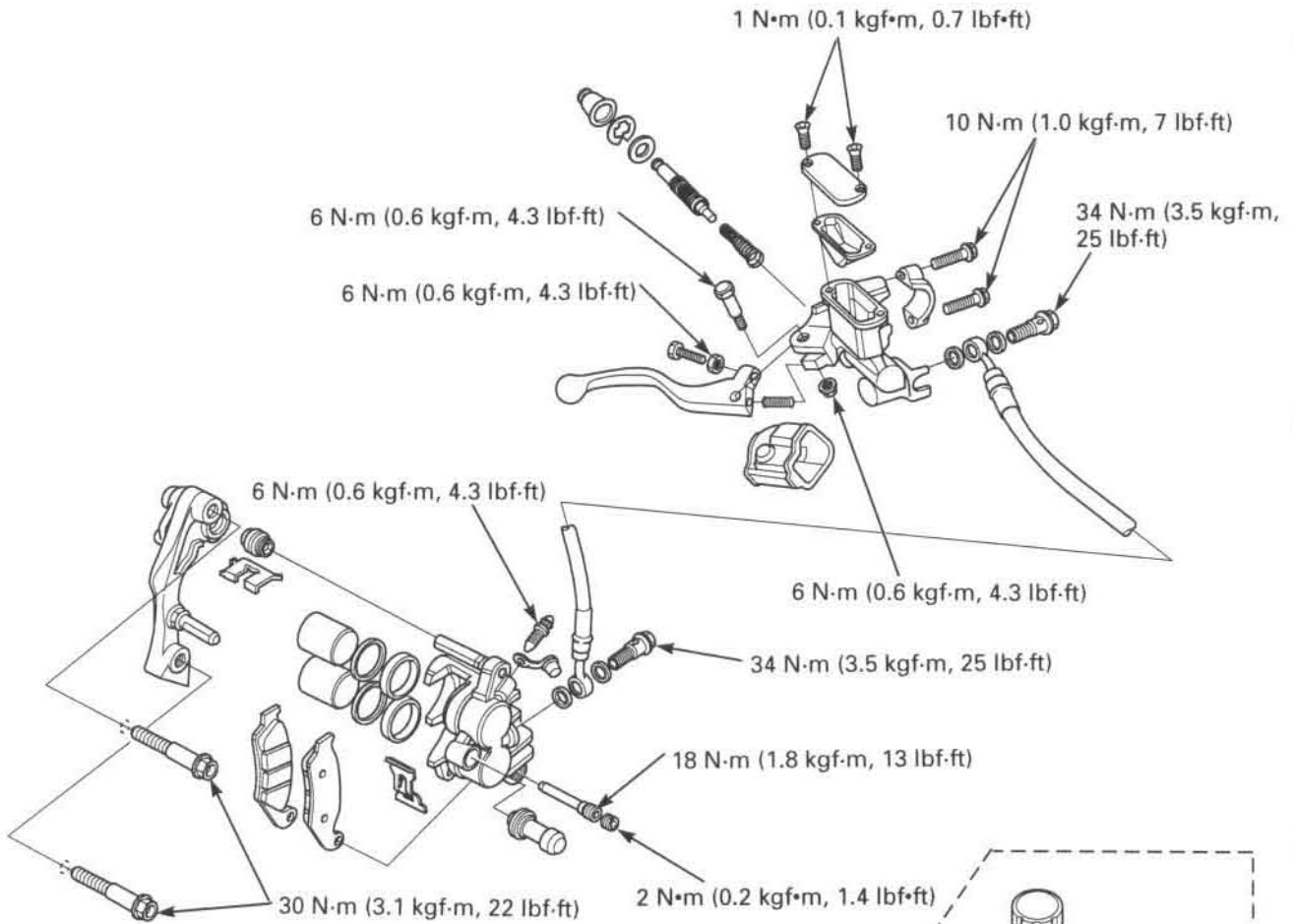

2000 - 2001:

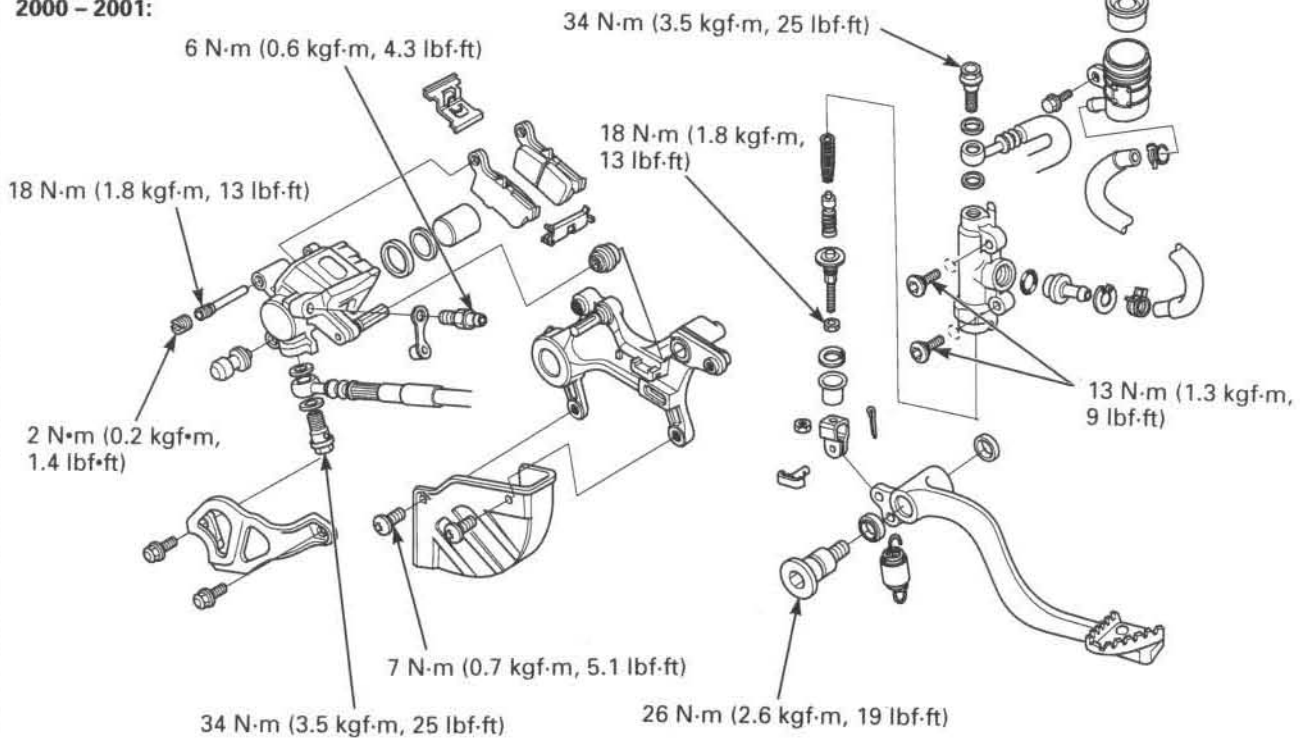

13. HYDRAULIC BRAKE

SERVICE INFORMATION	13-2	REAR MASTER CYLINDER	13-12
TROUBLESHOOTING	13-3	FRONT BRAKE CALIPER	13-16
BRAKE FLUID REPLACEMENT/ AIR BLEEDING	13-4	REAR BRAKE CALIPER	13-19
BRAKE PAD/DISC	13-7	BRAKE PEDAL	13-22
FRONT MASTER CYLINDER	13-9		

After 2001:

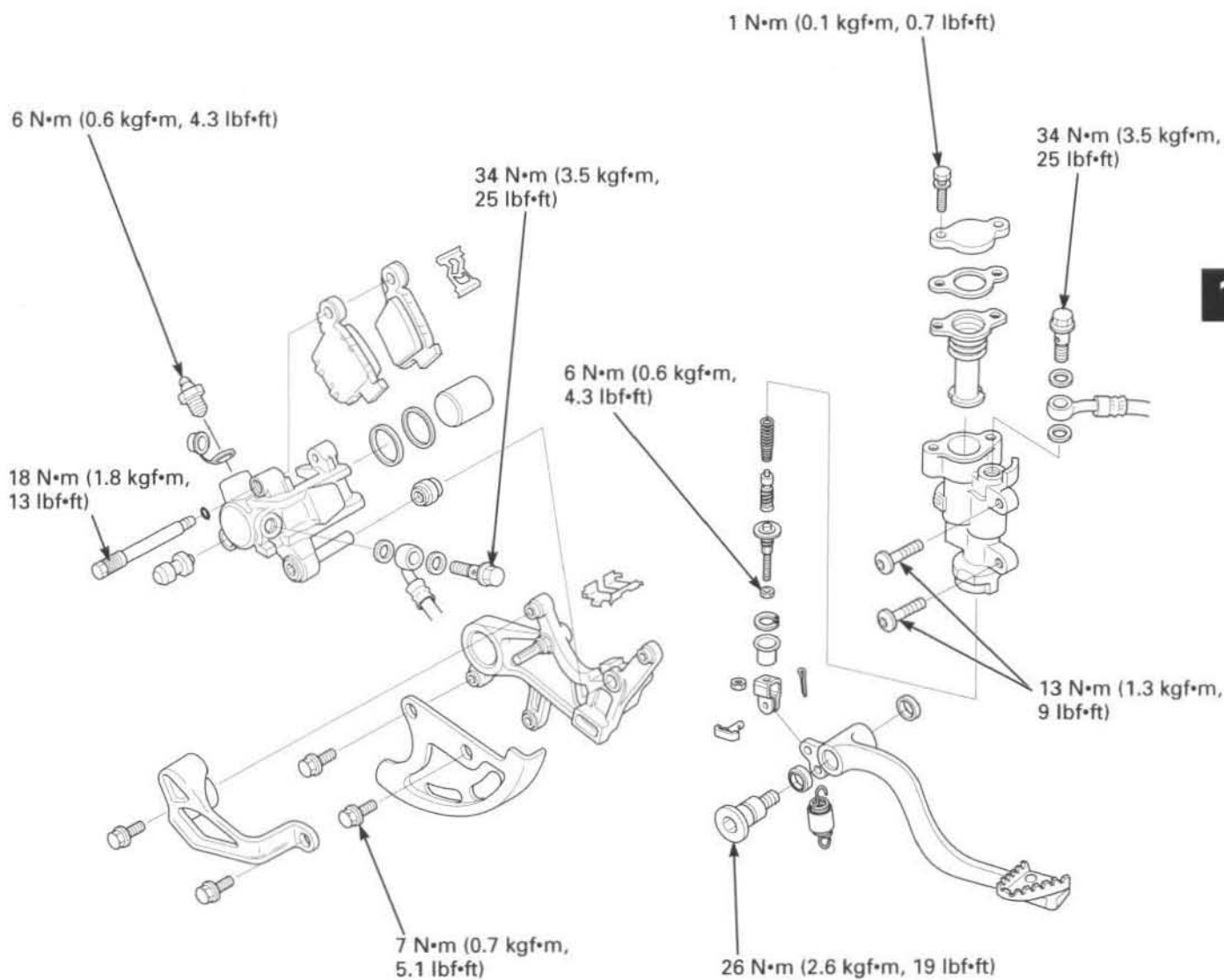

HYDRAULIC BRAKE

SERVICE INFORMATION

GENERAL

Keep grease off of brake pads and disc.

⚠ WARNING

A contaminated brake disc or pad reduces stopping power. Discard contaminated pads and clean a contaminated disc with a high quality brake degreasing agent.

- Never allow contaminants (dirt, water, etc.) to get into an open reservoir.
- Once the hydraulic system has been opened, or if the brake feels spongy, the system must be bled.
- Always use fresh DOT 4 brake fluid from a sealed container when servicing the system. Do not mix different types of fluid they may not be compatible.

CAUTION:

Spilled brake fluid will severely damage instrument lenses and painted surfaces. It is also harmful to some rubber parts. Be careful whenever you remove the reservoir cap; make sure the front reservoir is horizontal first.

- Always check brake operation before riding the motorcycle.

SPECIFICATIONS

Unit: mm (in)

ITEM		STANDARD	SERVICE LIMIT	
Front	Specified brake fluid	DOT 4	—	
	Brake pad wear indicator	—	1.0 (0.04)	
	Brake disc thickness	3.0 (0.12)	2.5 (0.10)	
	Brake disc runout	—	0.15 (0.006)	
	Master cylinder I.D.	11.000 – 11.043 (0.4330 – 0.4347)	11.05 (0.435)	
	Master piston O.D.	10.957 – 10.984 (0.4314 – 0.4324)	10.84 (0.427)	
	Caliper cylinder I.D.	27.000 – 27.050 (1.0630 – 1.0650)	27.06 (1.065)	
	Caliper piston O.D.	2000: 26.900 – 26.950 (1.0590 – 1.0610) After 2000: 26.861 – 26.894 (1.0575 – 1.0588)	26.89 (1.059) 26.85 (1.057)	
Rear	Specified brake fluid	DOT 4	—	
	Brake pad wear indicator	—	1.0 (0.04)	
	Brake disc thickness	4.0 (0.16)	3.5 (0.14)	
	Brake disc runout	—	0.15 (0.006)	
	Master cylinder I.D.	2000 – 2001:	12.700 – 12.743 (0.4999 – 0.5016)	12.76 (0.502)
		After 2001:	9.520 – 9.563 (0.3748 – 0.3765)	9.575 (0.3770)
	Master piston O.D.	2000 – 2001:	12.657 – 12.684 (0.4983 – 0.4993)	12.64 (0.498)
		After 2001:	9.477 – 9.504 (0.3731 – 0.3742)	9.465 (0.3726)
	Caliper cylinder I.D.	2000 – 2001:	27.000 – 27.050 (1.0630 – 1.0650)	27.06 (1.065)
		After 2001:	22.650 – 22.700 (0.8917 – 0.8937)	22.712 (0.8942)
	Caliper piston O.D.	2000 – 2001:	26.935 – 26.968 (1.0604 – 1.0617)	26.89 (1.059)
		After 2001:	22.585 – 22.618 (0.8892 – 0.8905)	22.573 (0.8887)

TORQUE VALUES

Brake hose oil bolt	34 N•m (3.5 kgf•m, 25 lbf•ft)	
Brake lever pivot bolt/nut	6 N•m (0.6 kgf•m, 4.3 lbf•ft)	
Brake lever adjuster lock nut	6 N•m (0.6 kgf•m, 4.3 lbf•ft)	
Front master cylinder reservoir cover screw	1 N•m (0.1 kgf•m, 0.7 lbf•ft)	
Front master cylinder holder bolt	10 N•m (1.0 kgf•m, 7 lbf•ft)	
Front caliper mounting bolt	30 N•m (3.1 kgf•m, 22 lbf•ft)	Apply a locking agent.
Caliper bleed valve	6 N•m (0.6 kgf•m, 4.3 lbf•ft)	
Rear brake disc guard mounting screw	7 N•m (0.7 kgf•m, 5.1 lbf•ft)	
Rear master cylinder mounting bolt	13 N•m (1.3 kgf•m, 9 lbf•ft)	
Front caliper pin bolt	23 N•m (2.3 kgf•m, 17 lbf•ft)	Apply a locking agent.
Brake caliper pad pin	18 N•m (1.8 kgf•m, 13 lbf•ft)	
Brake caliper pad pin plug	2 N•m (0.2 kgf•m, 1.4 lbf•ft)	
Rear caliper pin bolt	27 N•m (2.8 kgf•m, 20 lbf•ft)	
Rear caliper bracket pin bolt	13 N•m (1.3 kgf•m, 9 lbf•ft)	Apply a locking agent.
Brake pedal pivot bolt	26 N•m (2.6 kgf•m, 19 lbf•ft)	
Rear master cylinder joint nut (2000 – 2001:) (After 2001:)	18 N•m (1.8 kgf•m, 13 lbf•ft) 6 N•m (0.6 kgf•m, 4.3 lbf•ft)	
Rear master cylinder reservoir cover bolt (After 2001:)	1 N•m (0.1 kgf•m, 0.7 lbf•ft)	

TOOL

Snap ring pliers	07914 – SA50001
------------------	-----------------

TROUBLESHOOTING

Brake lever/pedal soft or spongy

- Air in hydraulic system
- Leaking hydraulic system
- Contaminated brake pads/disc
- Worn caliper piston seal
- Worn master cylinder piston cups
- Worn brake pads/disc
- Contaminated caliper
- Caliper not sliding properly
- Low brake fluid level
- Clogged fluid passage
- Warped/deformed brake disc
- Sticking/worn caliper piston
- Sticking/worn master cylinder piston
- Contaminated master cylinder
- Bent brake lever/pedal

Brake lever/pedal hard

- Clogged/restricted brake system
- Sticking/worn caliper piston
- Caliper not sliding properly
- Clogged/restricted fluid passage
- Worn caliper piston seal
- Sticking/worn master cylinder piston
- Bent brake lever/pedal

Brake drags

- Contaminated brake pads/disc
- Misaligned wheel
- Clogged/restricted brake hose joint
- Warped/deformed brake disc
- Caliper not sliding properly
- Clogged/restricted brake hydraulic system
- Sticking/worn caliper piston
- Clogged master cylinder port

BRAKE FLUID REPLACEMENT/AIR BLEEDING

⚠ WARNING

A contaminated brake disc or pad reduces stopping power. Discard contaminated pads and clean a contaminated disc with a high quality brake degreasing agent.

CAUTION:

- Do not allow foreign material to enter the system when filling the reservoir.
- Avoid spilling fluid on painted, plastic, or rubber parts. Place a rag over these parts whenever the system is serviced.

NOTE:

- The pedal brake line air bleeding procedure is performed in the same manner as in the lever brake line air bleeding procedure.
- Once the hydraulic system has been opened, or if the brake feels spongy, the system must be bled.
- When using a commercially available brake bleeder, follow the manufacturer's operating instructions.

BRAKE FLUID DRAINING

Make sure that the master cylinder is parallel to the ground, before removing the reservoir cover and cap.

FRONT:

Remove the screws, reservoir cover and diaphragm.

REAR; 2000 – 2001:

Remove the fuel tank (page 2-5).

Remove the reservoir cap, set plate and diaphragm.

REAR; After 2001:

Remove the bolts, reservoir cover and diaphragm.

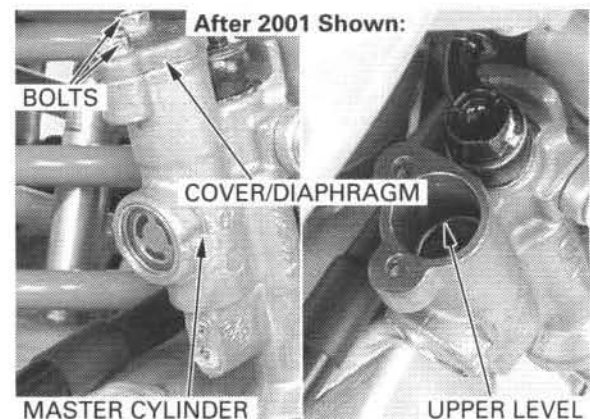
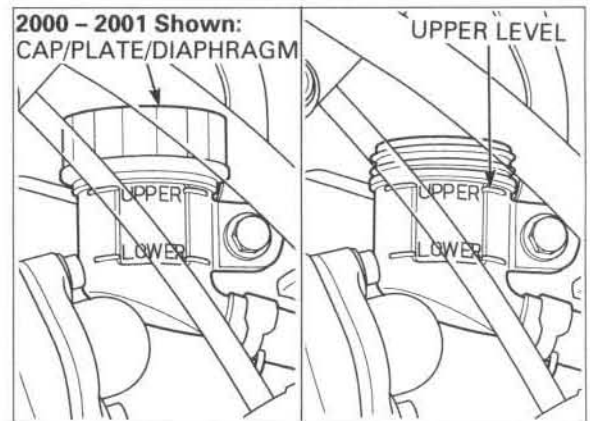
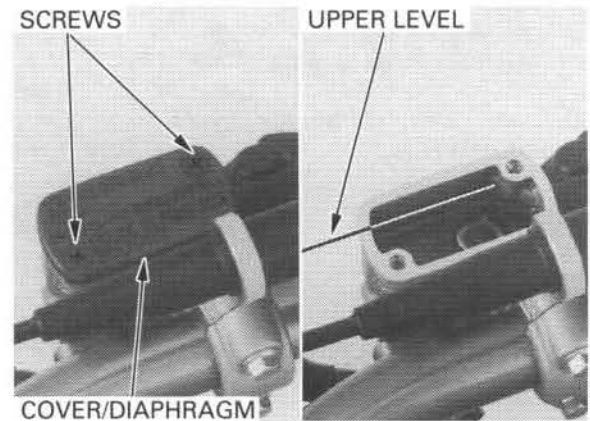
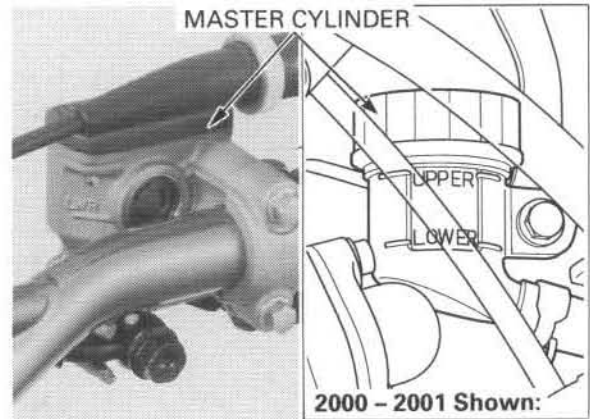

Connect a bleed hose to the bleed valve.

Loosen the bleed valve and pump the brake lever (pedal).
Stop operating the brake when no more fluid flows out of the bleed valve.

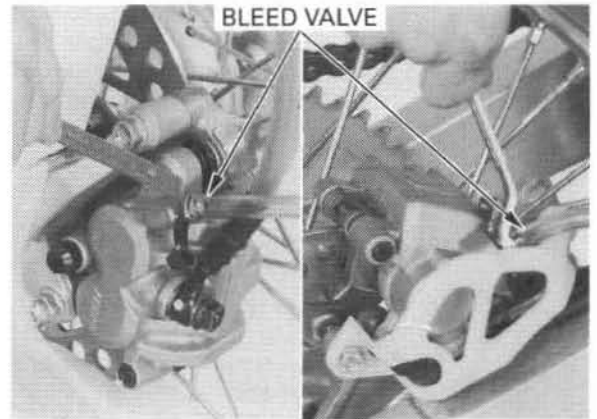

BRAKE FLUID FILLING/AIR BLEEDING

CAUTION:

Do not mix different types of fluid since they are not compatible.

Close the master cylinder with DOT 4 brake fluid to the upper level.

Connect the Mityvac Brake Bleeder No.6860 or equivalent to the bleed valve.

NOTE:

- Check the fluid level often while bleeding the brakes to prevent air from being pumped into the system.
- When using a brake bleeding tool, follow the manufacturer's operating instructions.

Pump the brake bleeder and loosen the bleed valve. Add fluid when the fluid level in the master cylinder is low to prevent drawing air into the system. Repeat the above procedures until no air bubbles appear in the plastic hose.

If air enters the bleeder from around the bleed valve threads, seal the threads with teflon tape.

If the brake bleeder is not available, perform the following procedure.

Pump up the system pressure with the lever until there are not air bubbles in the fluid flowing out of the reservoir small hole and lever (pedal) resistance is felt.

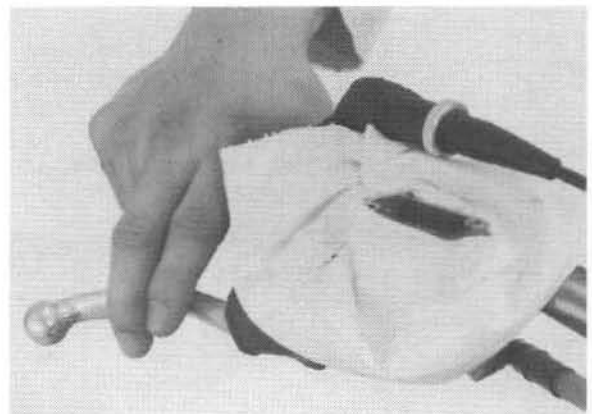
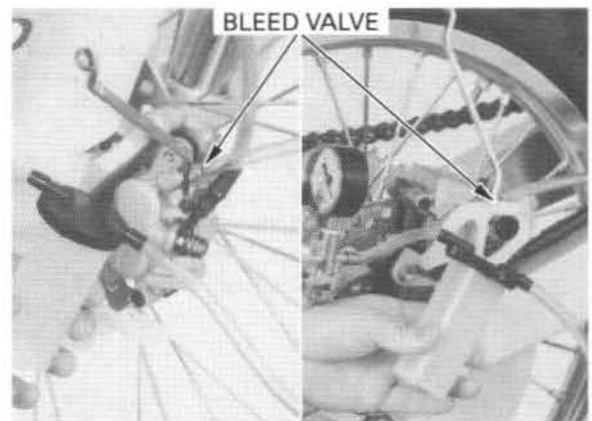
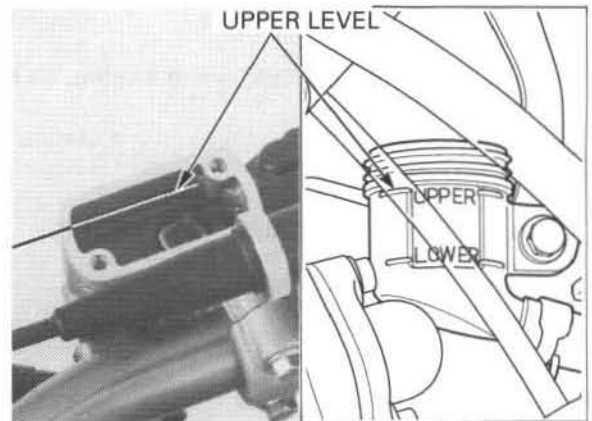

HYDRAULIC BRAKE

1. Pump the brake lever or pedal several times, then squeeze the brake lever or pedal all the way and loosen the bleed valve 1/2 turn. Wait several seconds and close the bleed valve.

NOTE:

Do not release the brake lever or pedal until the bleed valve has been closed.

2. Release the brake lever or pedal slowly until the bleed valve has been closed.
3. Repeat steps 1 and 2 until there are no air bubbles in the bleed hose.

After bleeding air completely, tighten the bleed valves to the specified torque.

TORQUE: 6 N·m (0.6 kgf·m, 4.3 lbf·ft)

Fill the reservoir to the casting ledge with DOT 4 brake fluid to the upper level.

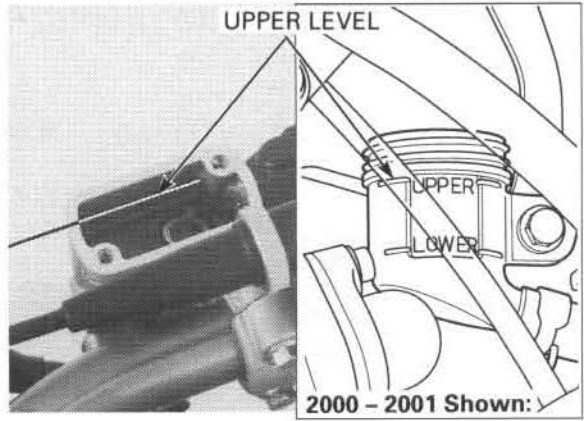
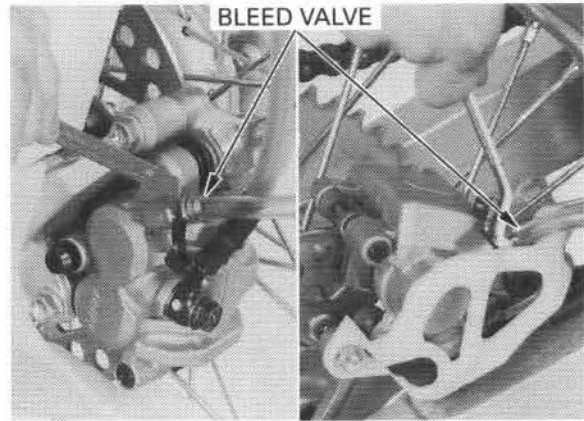

FRONT:

Install the diaphragm and reservoir cover. Tighten the reservoir cover screws to the specified torque.

TORQUE: 1 N·m (0.1 kgf·m, 0.7 lbf·ft)

REAR; 2000 - 2001:

Install the diaphragm, set plate and reservoir cap. Install the fuel tank (page 2-5).

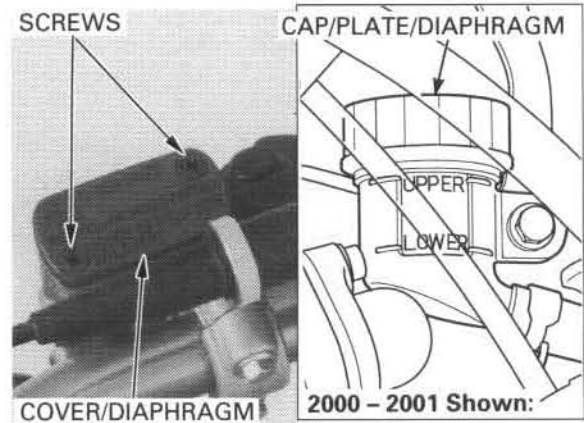

REAR; After 2001:

Install the diaphragm and reservoir cover. Tighten the reservoir cover bolts to the specified torque.

TORQUE: 1 N·m (0.1 kgf·m, 0.7 lbf·ft)

NOTE:

Do not bend the diaphragm while installation.

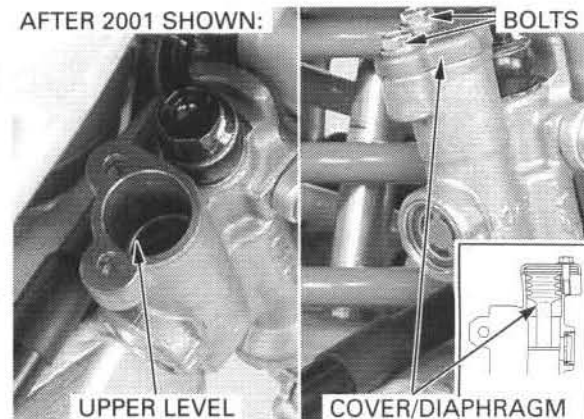

BRAKE PAD/DISC

BRAKE PAD REPLACEMENT

⚠ WARNING

A contaminated brake disc or pad reduces stopping power. Discard contaminated pads and clean a contaminated disc with a high quality brake degreasing agent.

Remove the brake disc cover (page 11-4).

Always replace the brake pads in pairs to assure even disc pressure.

Push the caliper pistons all the way in to allow installation of new brake pads.

NOTE:

Check the brake fluid level in the brake master cylinder reservoir as this operation causes the level to rise.

Remove the pad pin plug and remove the pad pin.

After 2001:

REAR:

Remove the pad pin.
Remove the O-ring from the pad pin.

Remove the brake pads.

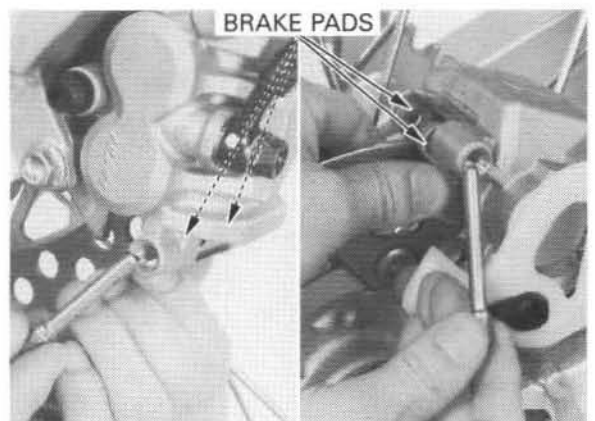
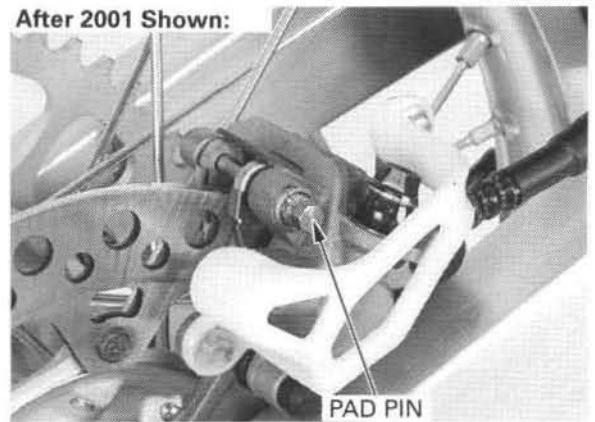
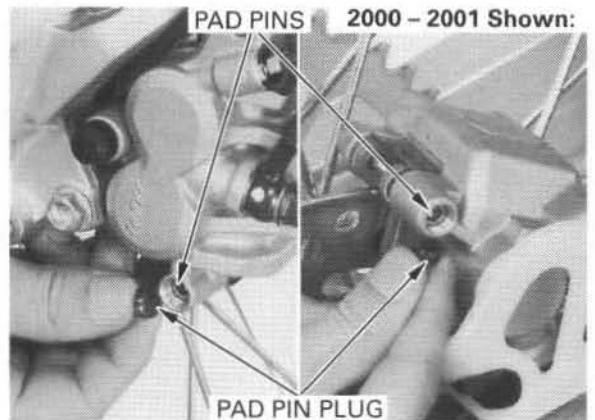
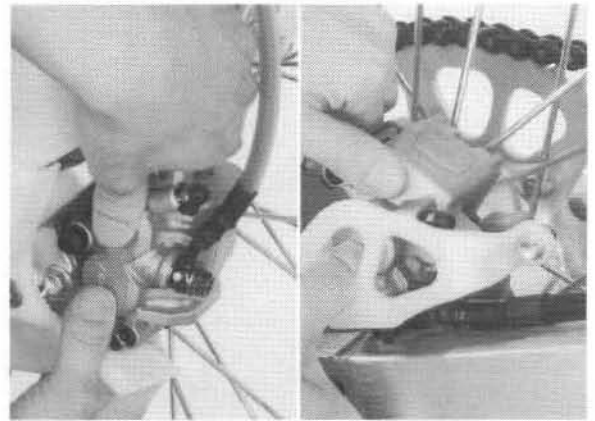

HYDRAULIC BRAKE

Install the new brake pads to the pad retainer securely.

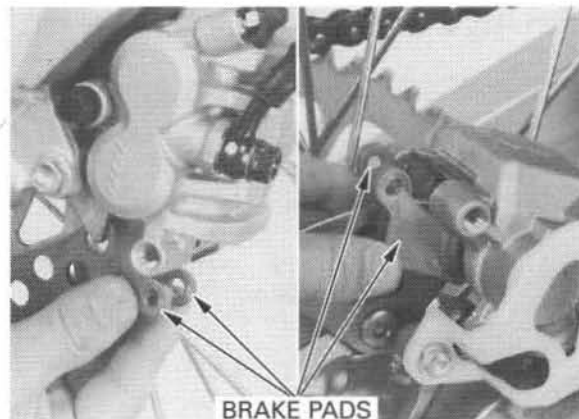

After 2001: **Rear:**
Set the new O-ring in the groove of the pad pin.

Push the brake pads against the pad spring, then install the pad pin plug.

Tighten the pad pin to the specified torque.

TORQUE: 18 N·m (1.8 kgf·m, 13 lbf·ft)

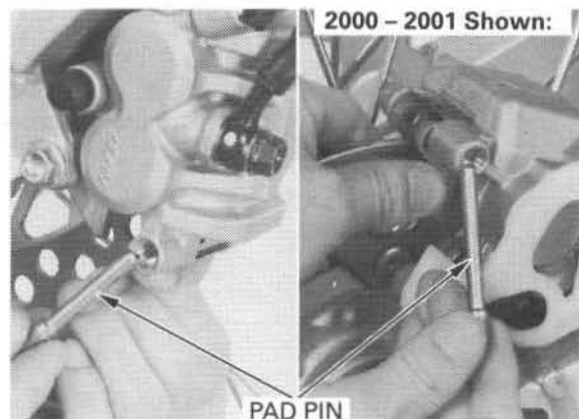

After 2001 Shown:

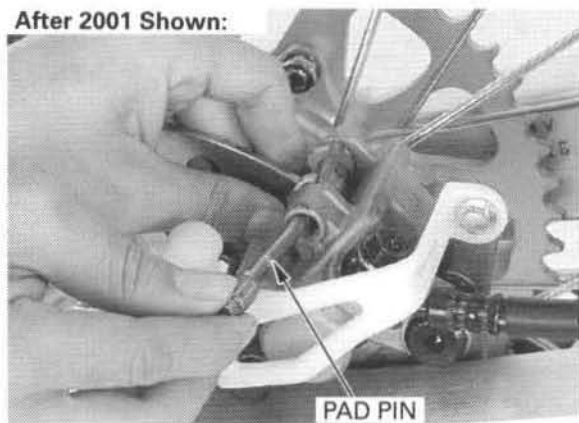

Install and tighten the pad pin plug.

TORQUE: 2 N·m (0.2 kgf·m, 1.4 lbf·ft)

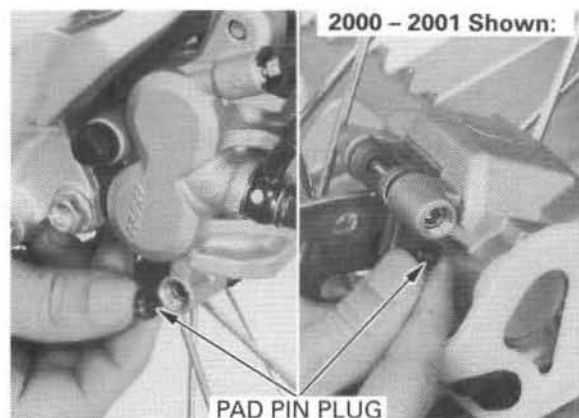

BRAKE DISC INSPECTION

Remove the brake disc cover (page 11-4).

Visually inspect the brake disc for damage or cracks.

Measure the brake disc thickness with a micrometer.

SERVICE LIMITS:

FRONT: 2.5 mm (0.10 in)

REAR: 3.5 mm (0.14 in)

Replace the brake disc if the smallest measurement is less than the service limit.

Measure the brake disc warpage with a dial indicator.

SERVICE LIMIT: 0.15 mm (0.006 in)

Check the wheel bearings for excessive play, if the warpage exceeds the service limit.

Replace the brake disc if the wheel bearings are normal.

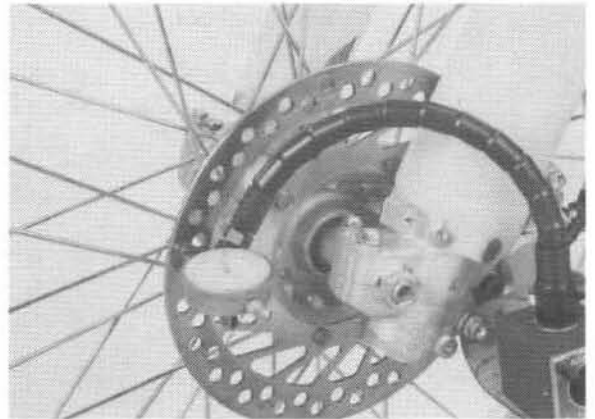
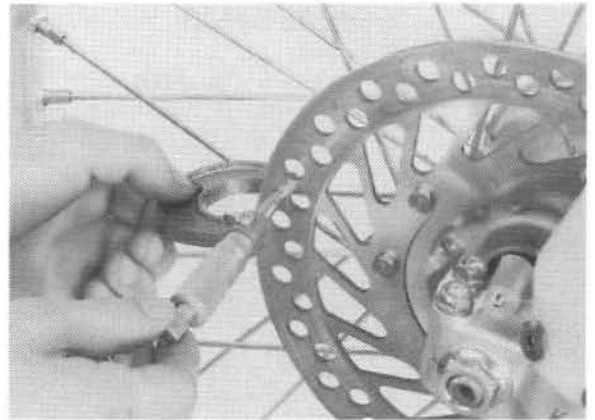

FRONT MASTER CYLINDER

REMOVAL

CAUTION:

Avoid spilling fluid on painted, plastic, or rubber parts. Place a rag over these parts whenever the system is serviced.

NOTE:

When removing the brake hose bolt, cover the end of the hose to prevent contamination. Secure the hose to prevent fluid from leaking out.

Drain the brake hydraulic system (page 13-4).

Remove the brake hose oil bolt, sealing washers and brake hose eyelet.

Remove the bolts from the master cylinder holder and remove the master cylinder assembly.

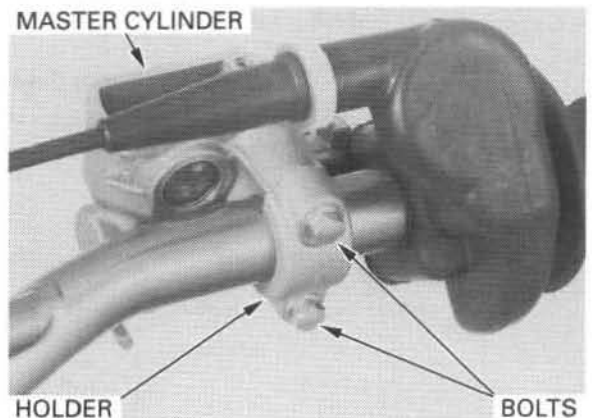
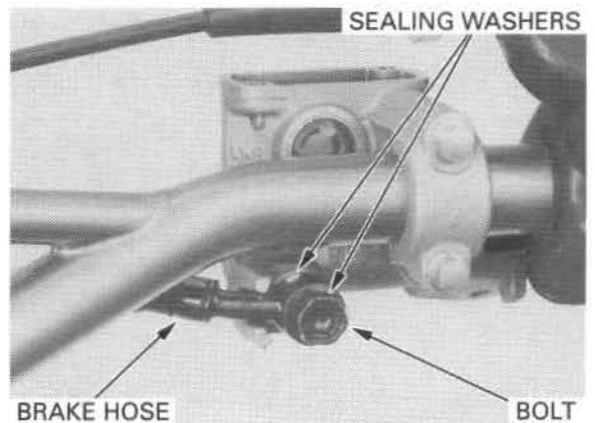

HYDRAULIC BRAKE

DISASSEMBLY

Remove the dust cover.
Remove the pivot bolt/nut and brake lever assembly.

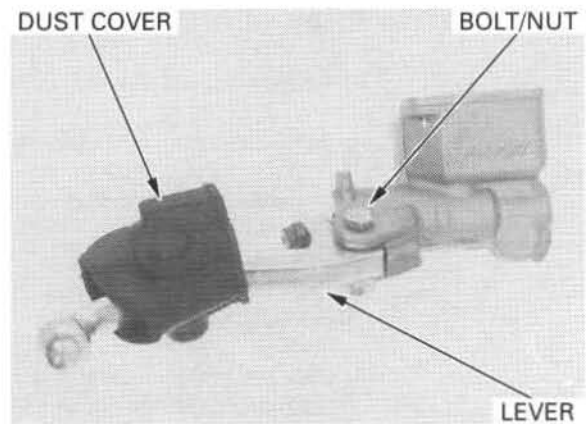

Remove the boot.

Remove the snap ring from the master cylinder body using the special tool as shown.

TOOL:

Snap ring pliers

07914-SA50001

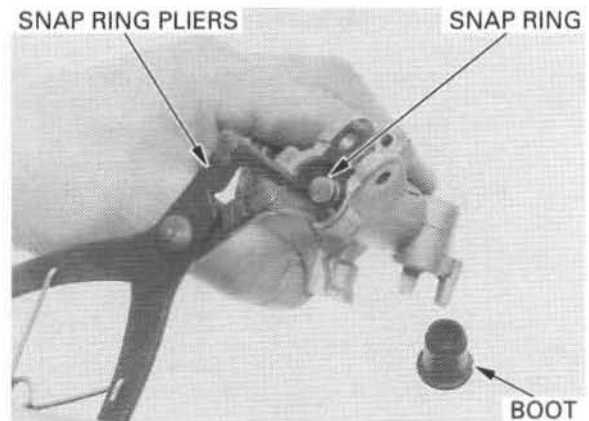

Remove the master piston and spring.

Clean the inside of the cylinder and reservoir with brake fluid.

INSPECTION

Check the piston boot, primary cup and secondary cup for fatigue or damage.
Check the master cylinder and piston for abnormal scratches.

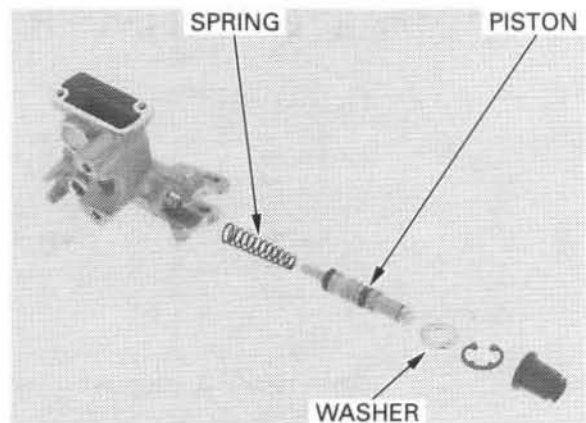

Measure the master cylinder I.D.

SERVICE LIMIT: 11.05 mm (0.435 in)

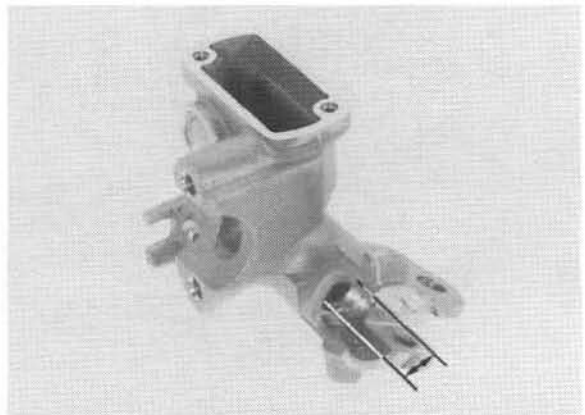

Measure the master cylinder piston O.D.

SERVICE LIMIT: 10.84 mm (0.427 in)

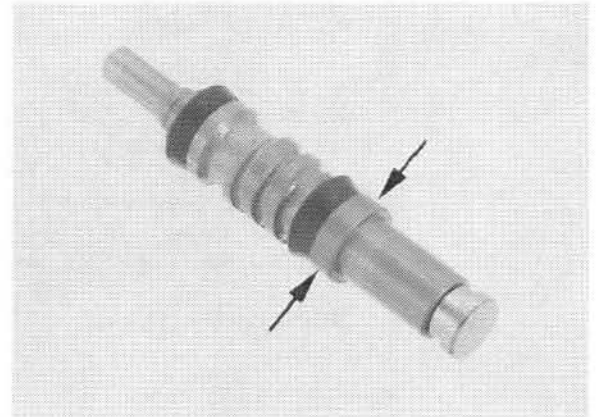

ASSEMBLY

CAUTION:

Keep the piston, cups, spring, snap ring and boot as a set; do not substitute individual parts.

Coat all parts with clean brake fluid before assembly.
Dip the piston in brake fluid.
Install the spring to the piston.
Install the piston assembly into the master cylinder.

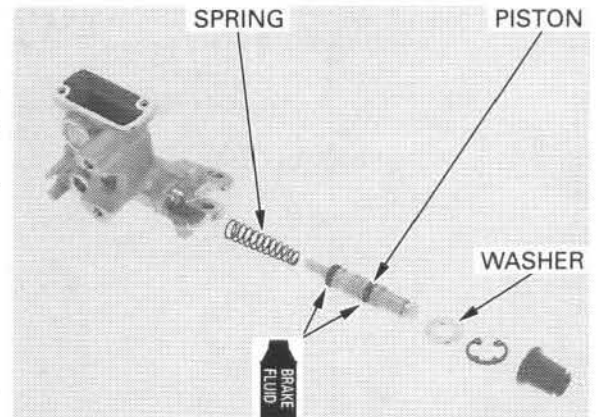

CAUTION:

When installing the cups, do not allow the lips to turn inside out.

Install the snap ring using the special tool.

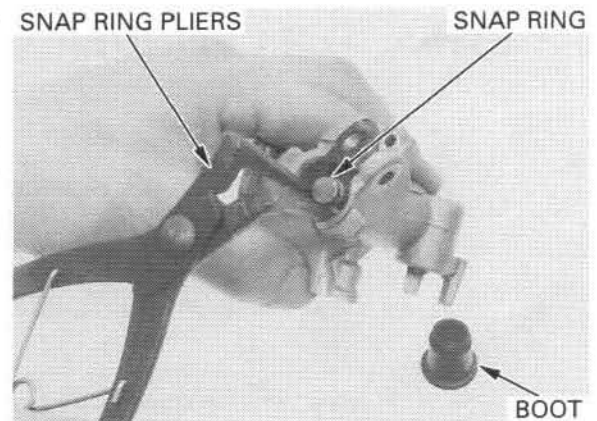

CAUTION:

Be certain the snap ring is firmly seated in the groove.

TOOL:

Snap ring pliers 07914-SA50001

Apply silicone grease to the inside of the boot.
Install the boot.

Install the brake lever.
Install and tighten the pivot bolt to the specified torque.

TORQUE: 6 N·m (0.6 kgf·m, 4.3 lbf·ft)

Hold the pivot nut to the specified torque.

TORQUE: 6 N·m (0.6 kgf·m, 4.3 lbf·ft)

Install the dust cover.

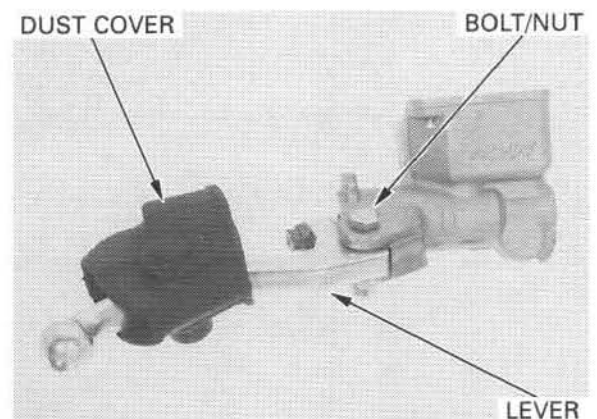

INSTALLATION

Place the master cylinder assembly on the handlebar. Align the end of the master cylinder with the punch mark on the handlebar.

Install the master cylinder holder with the "UP" mark facing up. Tighten the upper bolt first, then the lower bolt.

TORQUE: 10 N·m (1.0 kgf·m, 7 lbf·ft)

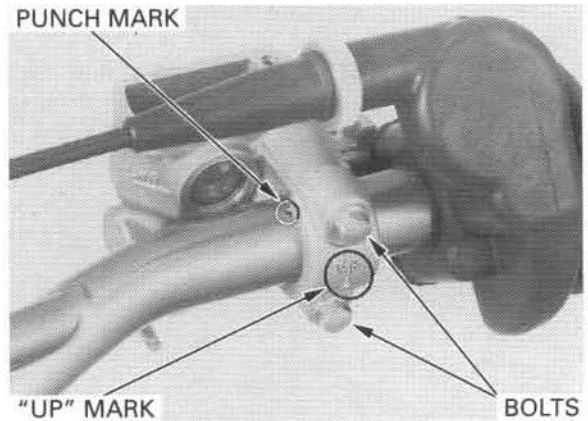

Align the brake hose eyelet between the stoppers. Install the brake hose eyelet with the oil bolt and new sealing washers. Tighten the oil bolt to the specified torque.

TORQUE: 34 N·m (3.5 kgf·m, 25 lbf·ft)

Fill the reservoir to the upper level and bleed the brake system (page 13-4).

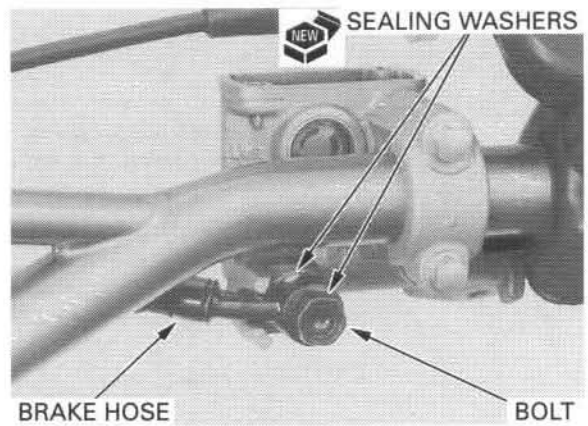

REAR MASTER CYLINDER

REMOVAL

CAUTION

Avoid spilling fluid on painted, plastic, or rubber parts. Place a rag over these parts whenever the system is serviced.

NOTE:

When removing the brake hose bolt, cover the end of the hose to prevent contamination. Secure the hose to prevent fluid from leaking out.

Drain the brake hydraulic system (page 13-4).

Remove the brake hose oil bolt, sealing washers and brake hose.

Remove the rear master cylinder mounting bolts.

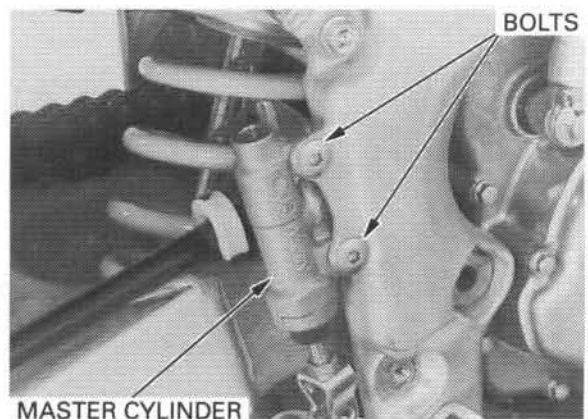
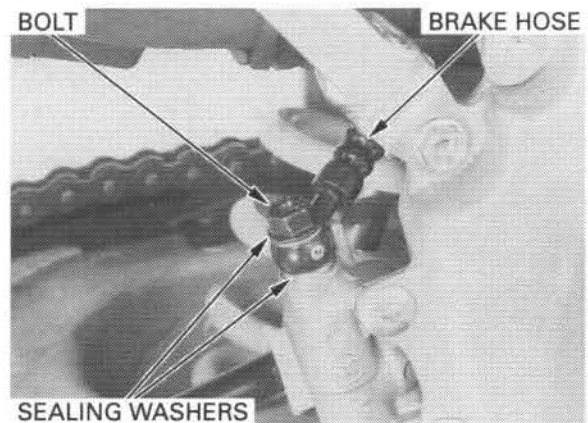

Remove the brake pedal pivot bolt (page 13-20).

Remove the cotter pin and the joint pin.

2000 – 2001: Remove the snap ring and disconnect the reservoir hose joint from the master cylinder.

TOOL:

Snap ring pliers 07914-SA50001

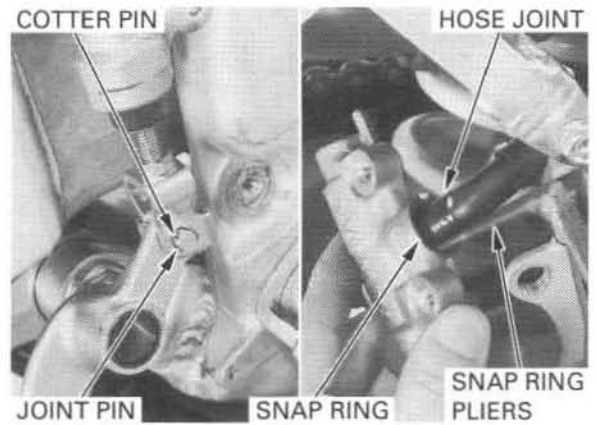

DISASSEMBLY

Remove the boot.

Remove the snap ring from the master cylinder body using the special tool as shown.

TOOL:

Snap ring pliers 07914-SA50001

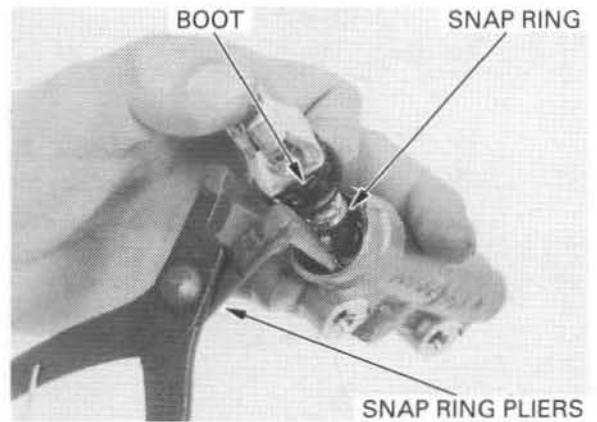

Remove the push rod, master piston and spring.

Clean the inside of the cylinder with brake fluid.

INSPECTION

Check the piston boot, primary cup and secondary cup for fatigue or damage.
Check the master cylinder and piston for abnormal scratches.

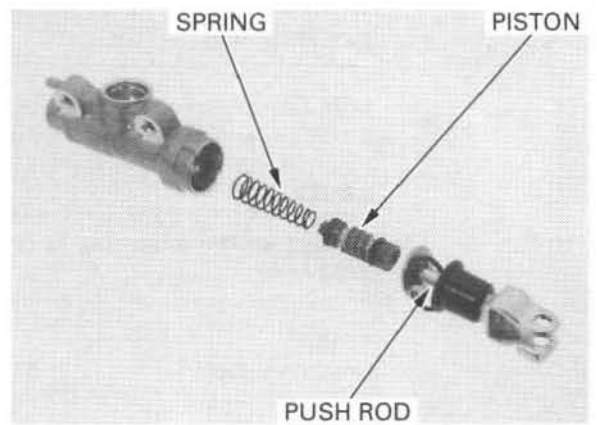

Measure the master cylinder I.D.

SERVICE LIMIT:

(2000 – 2001:) 12.76 mm (0.502 in)
(After 2001:) 9.575 mm (0.3770 in)

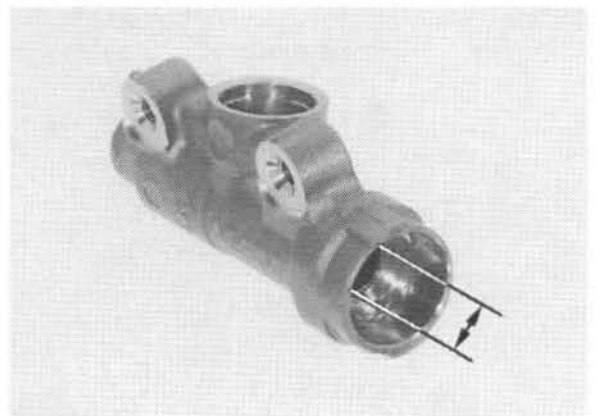

HYDRAULIC BRAKE

Measure the master cylinder piston O.D.

SERVICE LIMIT:

(2000 – 2001:) 12.64 mm (0.498 in)

(After 2001:) 9.465 mm (0.3726 in)

ASSEMBLY

CAUTION:

Keep the piston, cups, spring, snap ring and boot as a set; do not substitute individual parts.

Coat all parts with clean brake fluid before assembly.
Dip the piston in brake fluid.
Install the spring to the piston.
Install the piston assembly.
Apply grease to the piston contact area of the push rod.

CAUTION:

When installing the cups, do not allow the lips to turn inside out.

Install the push rod into the master cylinder.
Install the snap ring using the special tool.

CAUTION:

Be certain the snap ring is firmly seated in the groove.

TOOL:

Snap ring pliers

07914-SA50001 or
equivalent com-
mercially avail-
able in U.S.A.

Install the boot.

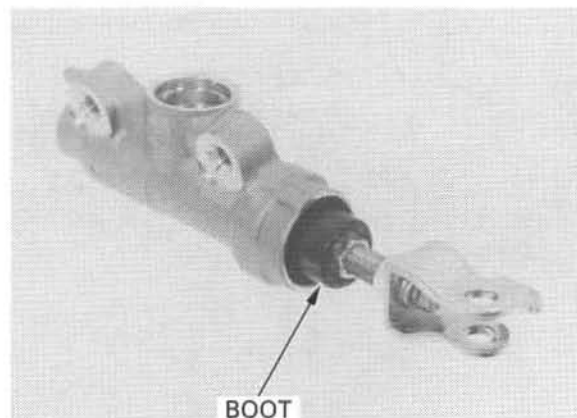
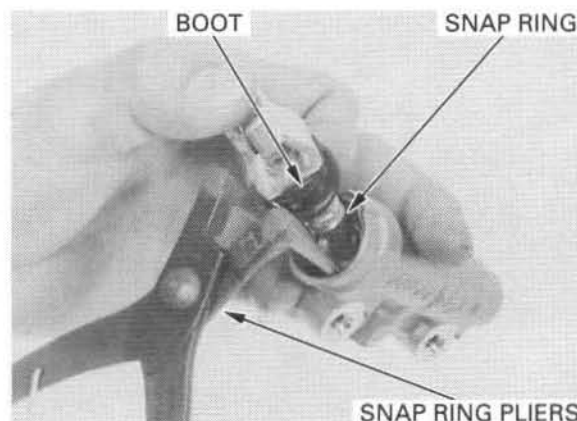
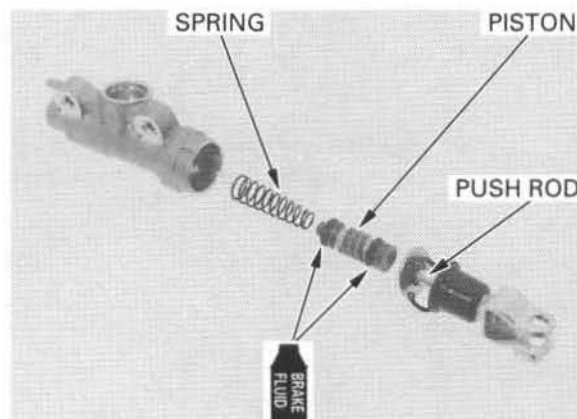
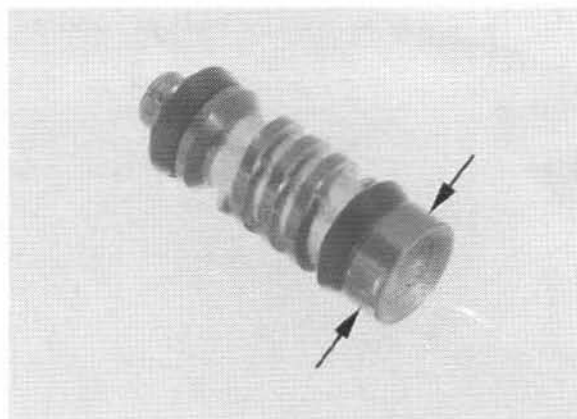

INSTALLATION

2000 – 2001: Apply brake fluid to a new O-ring and install it onto the reservoir hose joint.

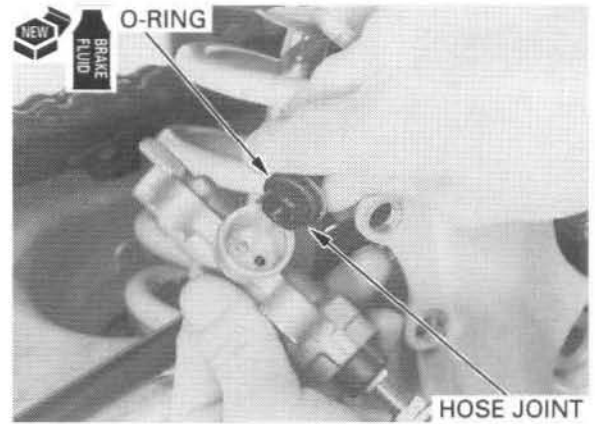

2000 – 2001: Install the reservoir hose joint to the rear master cylinder. Install the snap ring using the special tool.

CAUTION:

Be certain the snap ring is firmly seated in the groove.

TOOL:

Snap ring pliers 07914-SA50001

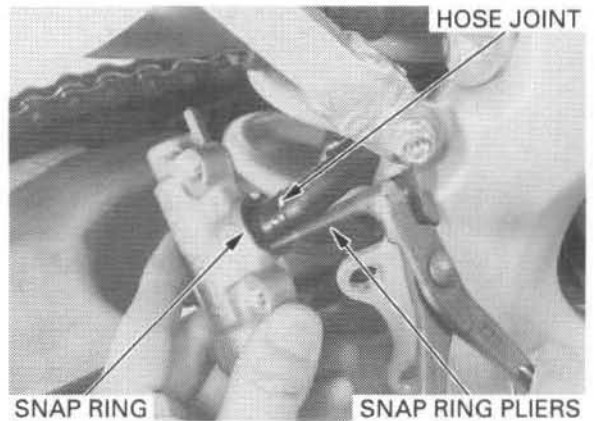

Connect the brake pedal to the push rod lower joint. Install the joint pin and secure it with a new cotter pin.

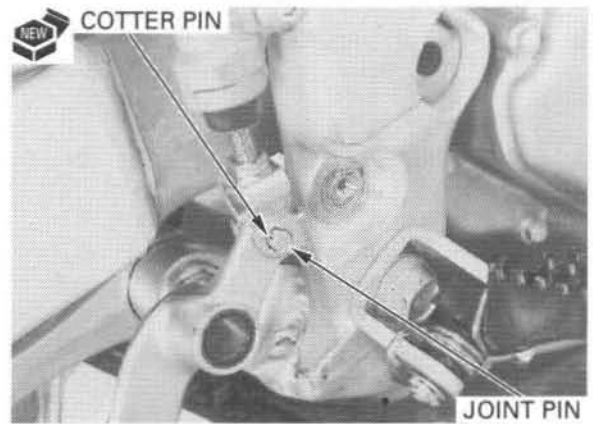

Install the rear master cylinder and tighten the mounting bolts to the specified torque.

TORQUE: 13 N·m (1.3 kgf·m, 9 lbf·ft)

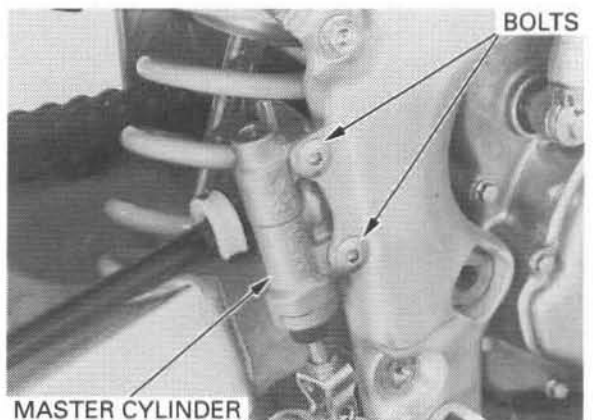

HYDRAULIC BRAKE

Install the brake hose with the oil bolt and new sealing washers.
Push the eyelet joint against the stopper, then tighten the oil bolt to the specified torque.

TORQUE: 34 N·m (3.5 kgf·m, 25 lbf·ft)

Fill the reservoir to the upper level and bleed the brake system (page 13-5).

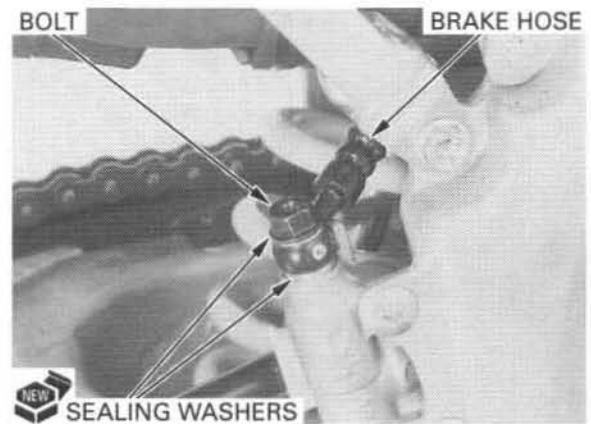

FRONT BRAKE CALIPER

REMOVAL

CAUTION:

Avoid spilling fluid on painted, plastic, or rubber parts. Place a rag over these parts whenever the system is serviced.

Drain the brake hydraulic system (page 13-3).
Remove the brake pads (page 13-5).

Remove the oil bolt, sealing washers and brake hose eyelet joints.

Remove the caliper mounting bolts and then remove the caliper and bracket as an assembly.

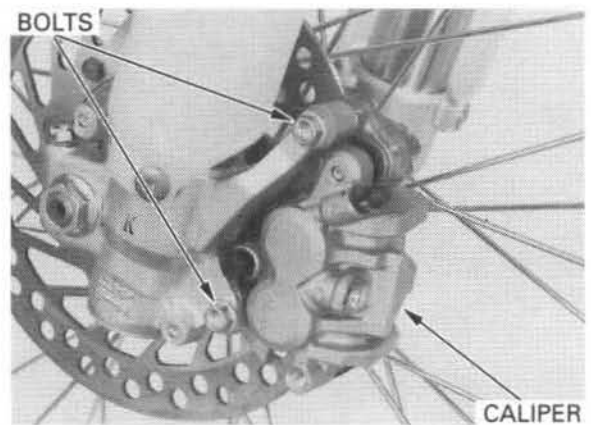
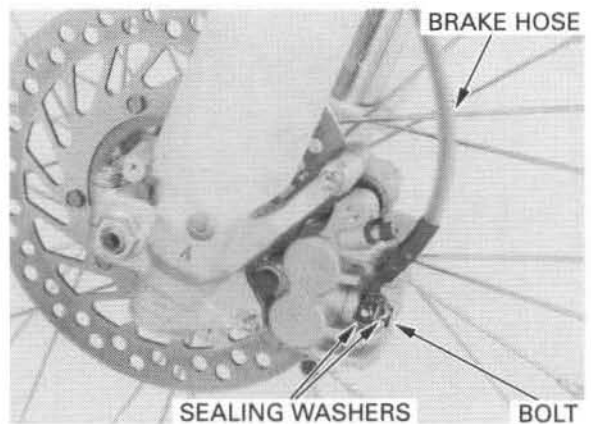

DISASSEMBLY

Remove the caliper bracket from the caliper body.

Remove the brake pad spring from the caliper body.
Remove the brake pad retainer from the caliper bracket.
Remove the caliper pin and bracket pin boots.

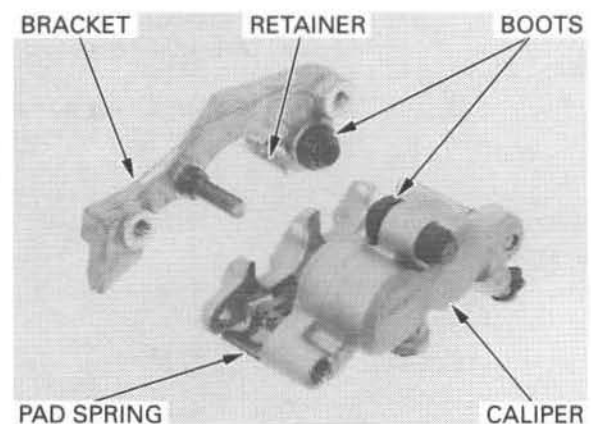

If necessary, lightly apply compressed air to the caliper fluid inlet to get the piston out.

Place the shop rag under the caliper to cushion the piston when it is expelled.
Use the air in short spurts.

⚠ WARNING

Do not bring the air nozzle too close to the inlet or the pistons may be forced out with excessive force that could cause injury.

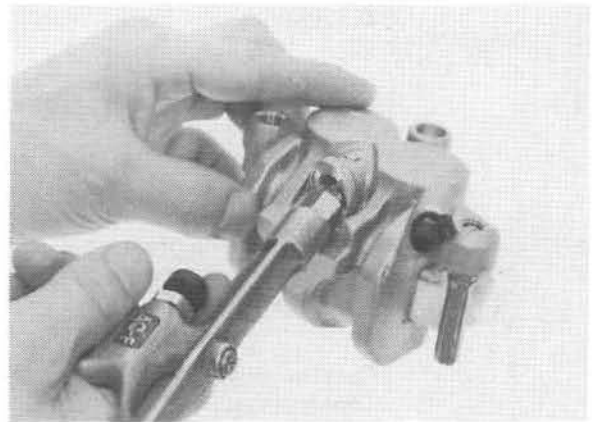

Push the dust seals and piston seals in and lift them out.

CAUTION:

Be careful not to damage the piston sliding surface.

Clean the seal grooves, caliper pistons and caliper piston sliding surfaces with clean brake fluid.

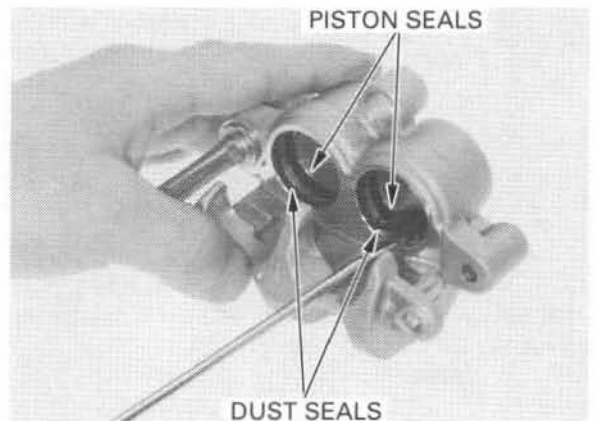

INSPECTION

Check the caliper cylinder and pistons for scoring, scratches or damage.

Measure the caliper cylinder I.D.

SERVICE LIMIT: 27.06 mm (1.065 in)

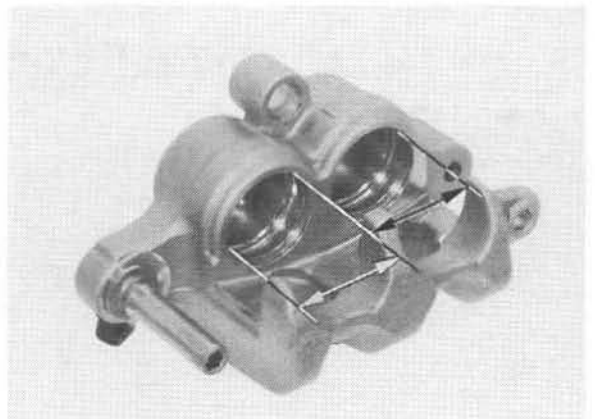

Measure the caliper piston O.D.

SERVICE LIMIT:

2000: 26.89 mm (1.059 in)
After 2000: 26.85 mm (1.057 in)

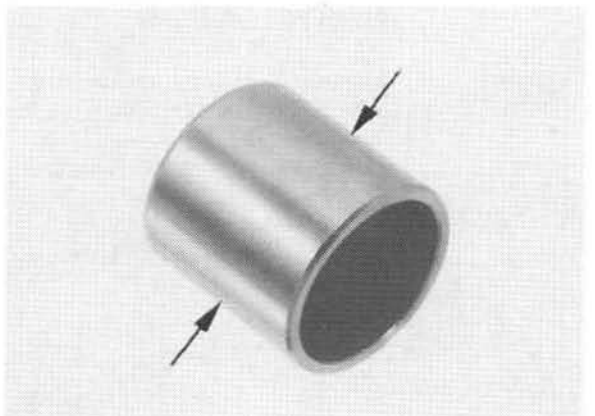

ASSEMBLY

NOTE:

- Replace the dust seals and piston seals with a new ones.
- Replace the caliper and bracket pin boots if there is wear, deterioration or damage.
- Apply silicone grease to the boot inner surface.
- Be sure that each part is free from the dust or dirt before reassembly.

Coat the new piston seals with clean brake fluid. Coat the new dust seals with silicone grease. Install the piston and dust seals into the groove of the caliper body. Coat the caliper pistons with clean brake fluid and install them into the caliper cylinder with their closed ends facing the pad.

NOTE:

Install the each piston seal, dust seal and caliper piston in their proper locations.

Install the brake pad retainer onto the caliper bracket. Install the pad spring into the caliper body.

Note the installation direction of the pad spring.

Apply silicone grease to the boot inside then install them.

When assembling the caliper and bracket, set the boot into the slide pin groove.

Assemble the caliper and bracket.

INSTALLATION

Install the caliper/bracket assembly to the fork leg. Clean and apply a locking agent to the caliper mounting bolt threads. Install and tighten the mounting bolts to the specified torque.

TORQUE: 30 N·m (3.1 kgf·m, 22 lbf·ft)

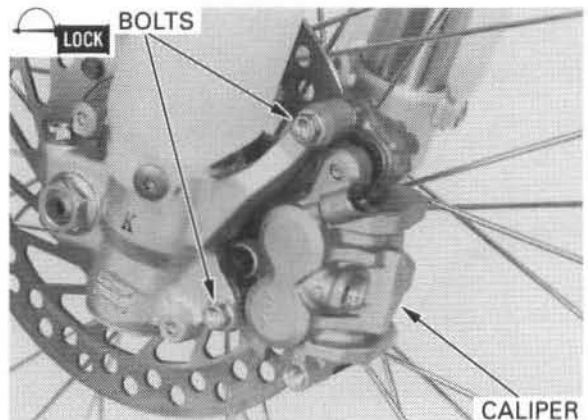
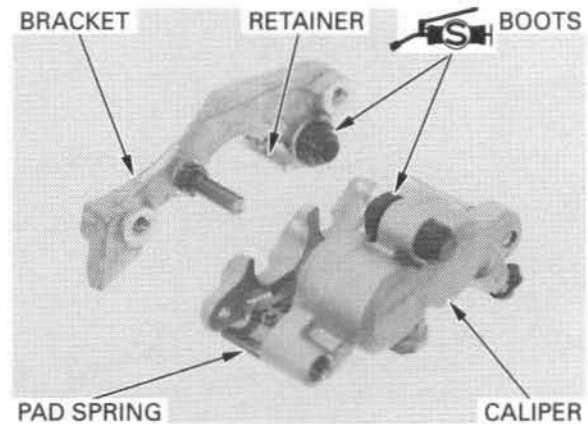
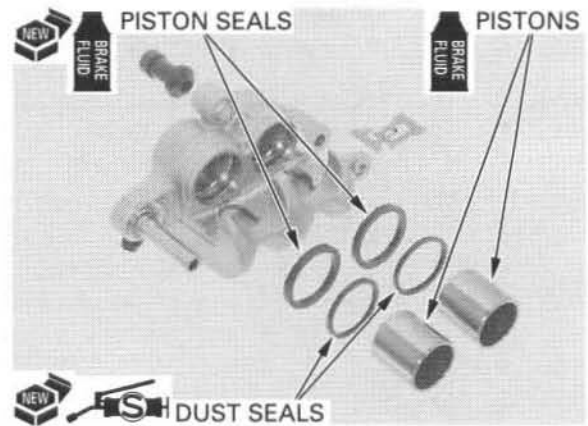

Install the brake hose eyelet to the caliper body with new sealing washers and oil bolts. Push the brake hose eyelet to the stopper on the caliper, then tighten the oil bolts to the specified torque.

TORQUE: 34 N·m (3.5 kgf·m, 25 lbf·ft)

Install the brake pad (page 13-6).
Fill and bleed the hydraulic system (page 13-4).
Install the brake disc cover (page 11-9).

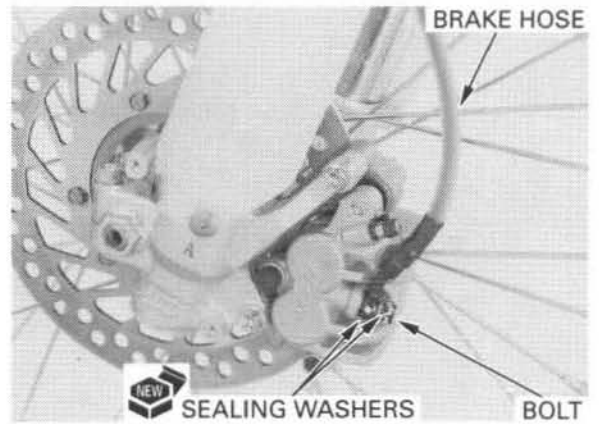

REAR BRAKE CALIPER

REMOVAL

CAUTION:

Avoid spilling fluid on painted, plastic, or rubber parts. Place a rag over these parts whenever the system is serviced.

Drain the brake hydraulic system (page 13-3).
Remove the brake pad (page 13-5).
Remove the rear wheel (page 12-4).

Slide the brake caliper backward and pull it off of the slide rail on the swingarm.

Remove the oil bolts, sealing washers and brake hose eyelet joint.

Remove the bolts and caliper guard plate.

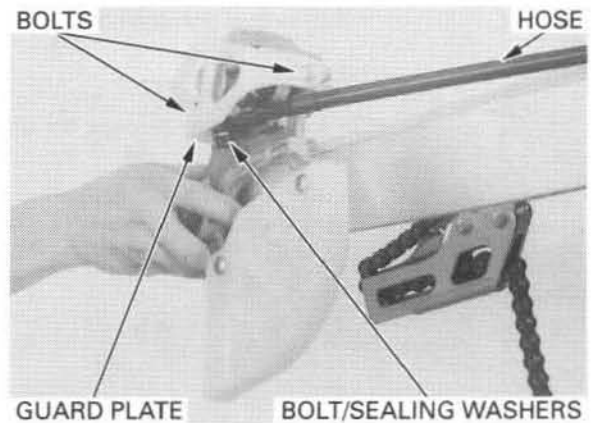
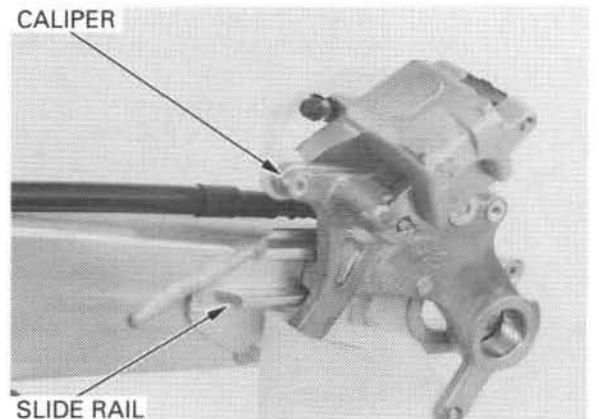

DISASSEMBLY

Remove the screws and brake disc cover.

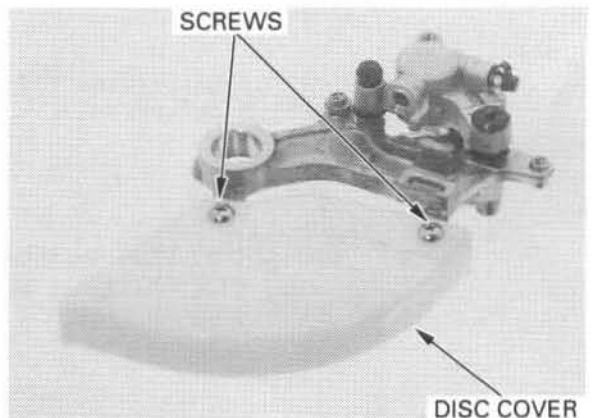

HYDRAULIC BRAKE

Remove the caliper bracket from the caliper body.

Remove the brake pad spring from the caliper body.
Remove the brake pad retainer from the caliper bracket.
Remove the caliper pin and bracket pin boots.

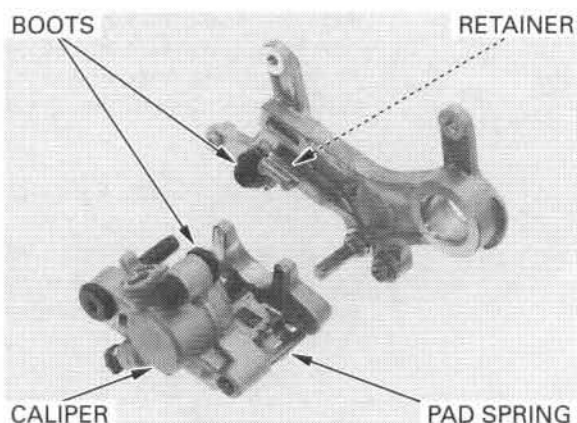

If necessary, lightly apply compressed air to the caliper fluid inlet to get the piston out.

Place a shop rag under the caliper to cushion the piston when it is expelled.
Use the air in short spurts.

⚠ WARNING

Do not bring the air nozzle too close to the inlet or the pistons may be forced out with excessive force that could cause injury.



Push the dust seal and piston seal in and lift them out.

CAUTION:

Be careful not to damage the piston sliding surface.

Clean the seal grooves, caliper piston and caliper piston sliding surface with clean brake fluid.

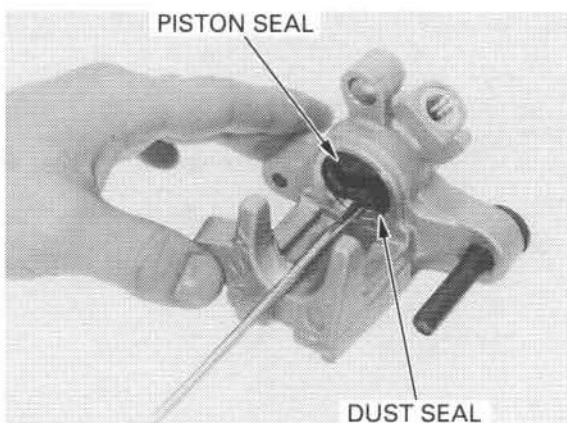

INSPECTION

Check the caliper cylinder and pistons for scoring, scratches or damage.

Measure the caliper cylinder I.D.

SERVICE LIMIT:

(2000 – 2001:) 27.06 mm (1.065 in)

(After 2001:) 22.712 mm (0.8942 in)

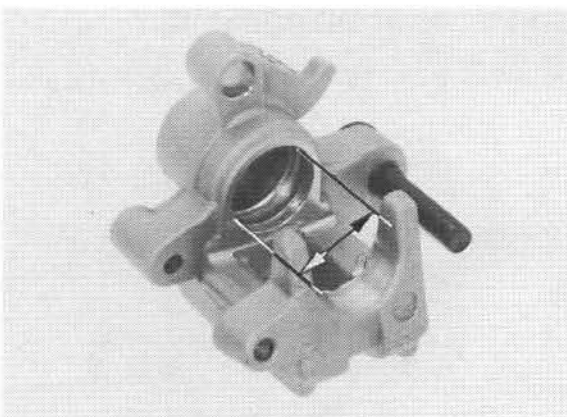

Measure the caliper piston O.D.

SERVICE LIMITS:

- (2000 – 2001:) 26.89 mm (1.059 in)
- (After 2001:) 22.573 mm (0.8887 in)

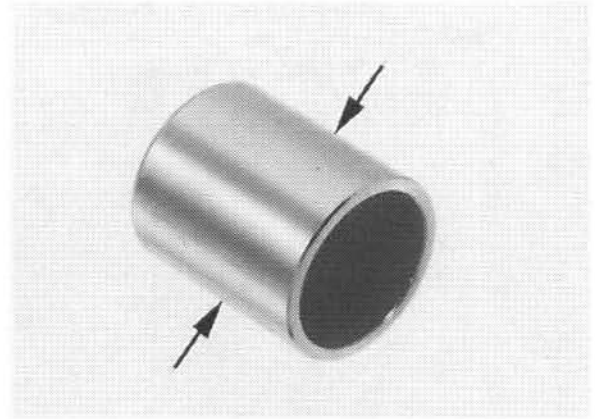

ASSEMBLY

NOTE:

- Replace the dust seal and piston seal with a new ones.
- Replace the caliper and bracket pin boots if there is wear, deterioration or damage.
- Apply silicone grease to the boot inner surface.
- Be sure that each part is free from dust or dirt before reassembly.

Coat the new piston seal with clean brake fluid.
 Coat the new dust seal with silicone grease.
 Install the piston and dust seals into the groove of the caliper body.
 Coat the caliper piston with clean brake fluid and install it into the caliper cylinder with its closed end facing the pad.

NOTE:

Install the piston seal, dust seal and caliper piston in their proper locations.

Install the brake pad retainer onto the caliper bracket.
 Install the pad spring into the caliper body.

Note the installation direction of the pad spring.

Apply silicone grease inside the boots then install them.

Assemble the caliper and bracket.

When assembling the caliper and bracket, set the boot into the side pin groove.

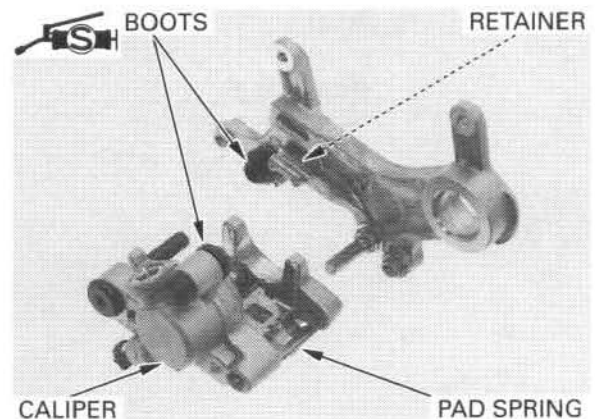
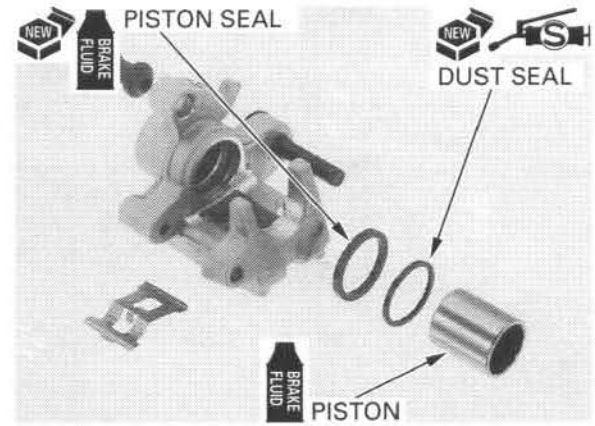

HYDRAULIC BRAKE

Clean and apply a locking agent to the screw threads. Install the brake disc cover and tighten the screw to the specified torque.

TORQUE: 7 N•m (0.7 kgf•m, 5.1 lbf•ft)

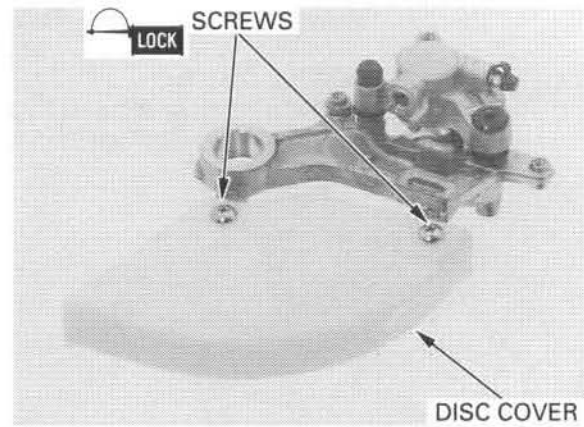

INSTALLATION

Install the caliper guard plate and tighten the bolts securely.

Temporarily install the brake hose eyelets to the caliper body with new sealing washers and oil bolts. Push the brake hose eyelet to the stopper on the caliper, then tighten the oil bolt to the specified torque.

TORQUE: 34 N•m (3.5 kgf•m, 25 lbf•ft)

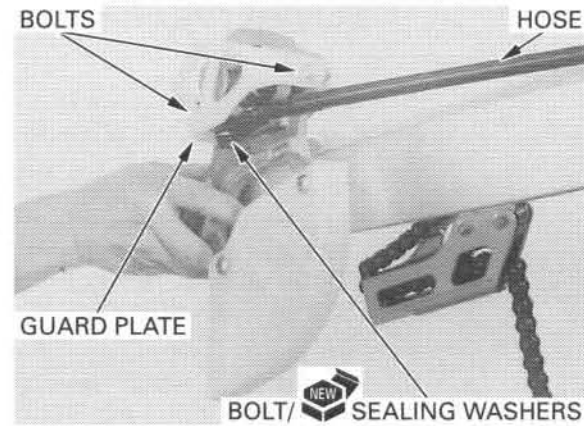

Install the caliper/bracket assembly onto the swingarm by aligning the bracket tab with the slide rail on the swingarm.

Install the rear wheel (page 12-8).
Install the brake pad (page 13-6).
Fill and bleed the hydraulic system (page 13-4).

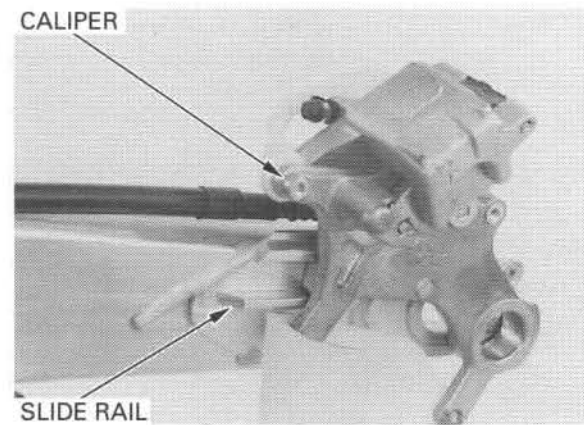

BRAKE PEDAL

REMOVAL

Remove the rear brake pedal pivot bolt and return spring.

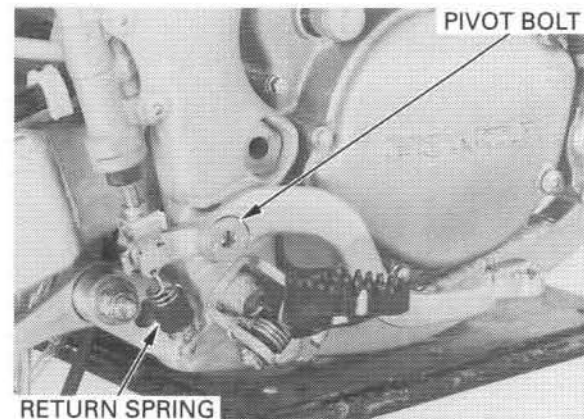

Remove and discard the cotter pin.
Remove the joint pin.

Remove the brake pedal.

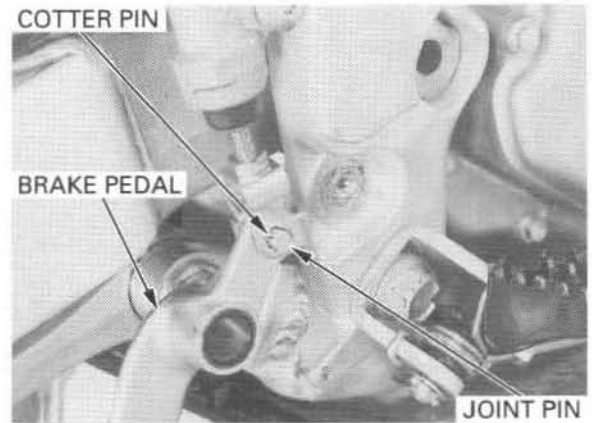

INSTALLATION

Install the brake pedal joint and secure it with a new cotter pin.

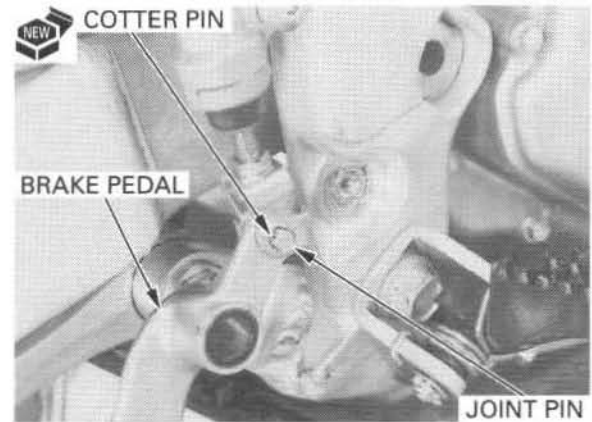

Apply grease to the sliding surface of the brake pedal and pivot bolt.

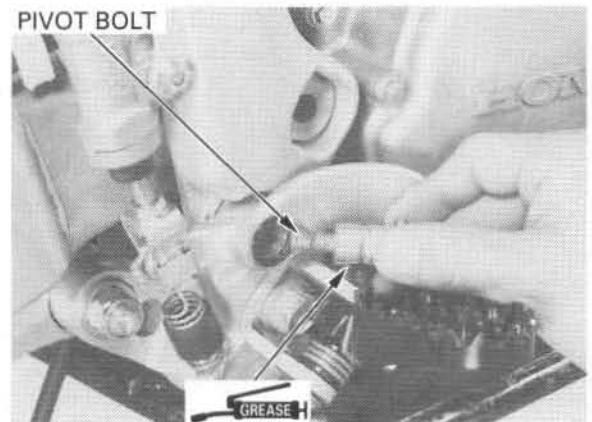

Install and tighten the rear brake pedal pivot bolt to the specified torque.

TORQUE: 25 N·m (2.6 kgf·m, 19 lbf·ft)

Install the return spring.

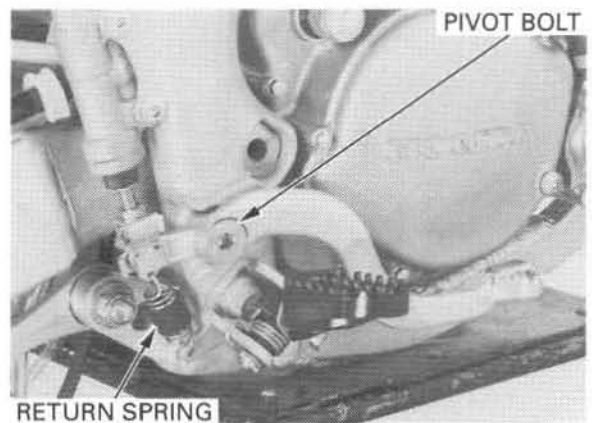

IGNITION SYSTEM/ALTERNATOR

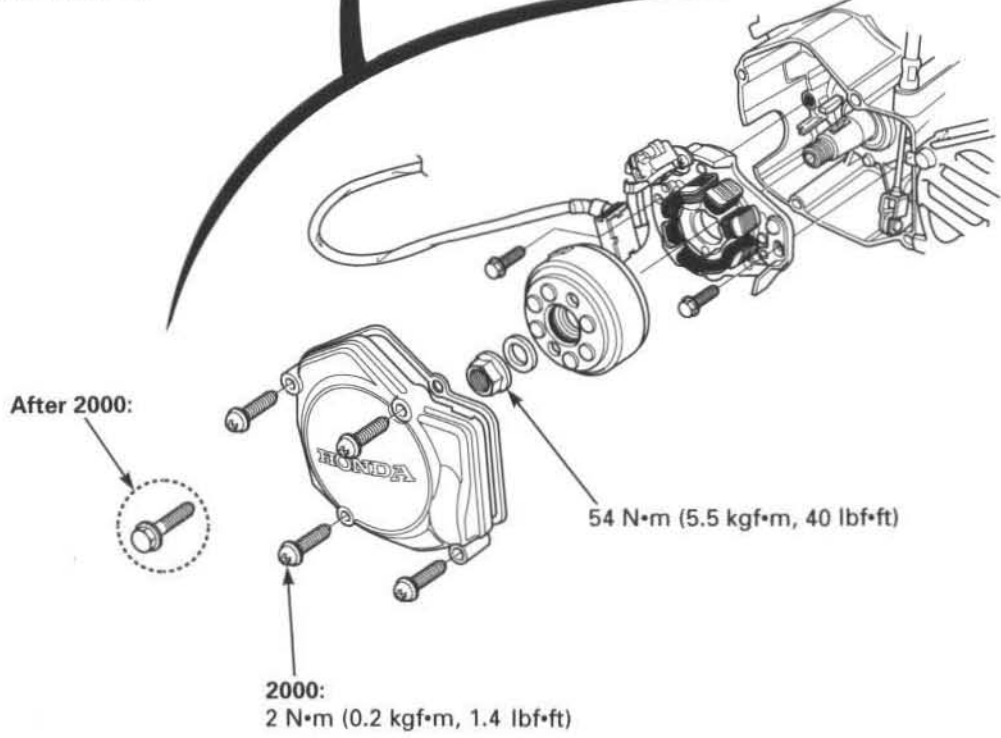
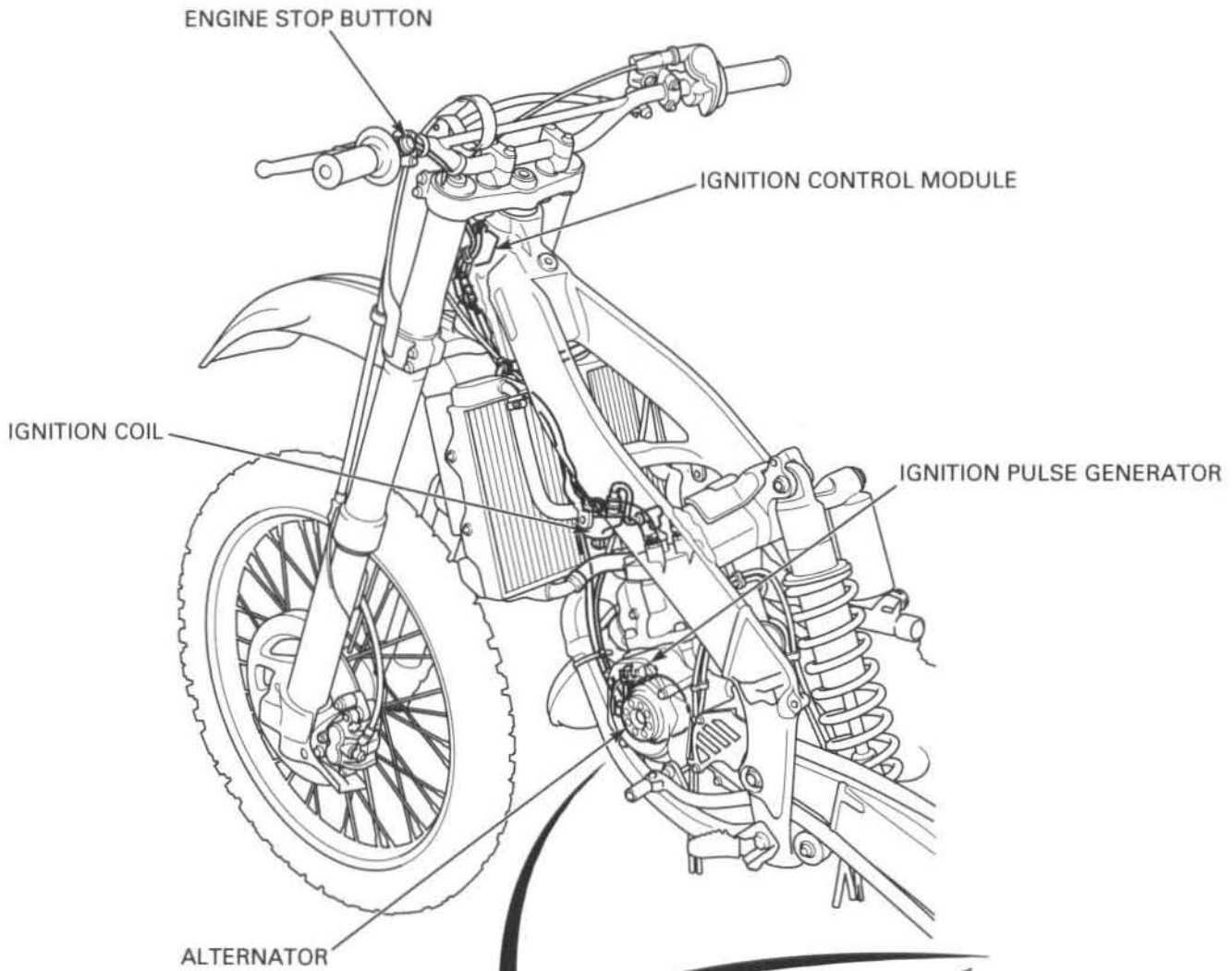

14. IGNITION SYSTEM/ALTERNATOR

SERVICE INFORMATION	14-1	EXCITER COIL	14-8
TROUBLESHOOTING	14-2	IGNITION PULSE GENERATOR	14-8
IGNITION SYSTEM INSPECTION	14-4	ALTERNATOR	14-8
ICM (IGNITION CONTROL MODULE)	14-6	IGNITION TIMING	14-11
IGNITION COIL	14-7	ENGINE STOP SWITCH	14-12

SERVICE INFORMATION

GENERAL

▲ WARNING

If the engine must be running to do some work, make sure the area is well ventilated. Never run the engine in an enclosed area. The exhaust contains poisonous carbon monoxide gas that may cause loss of consciousness and may lead to death.

CAUTION:

Some electrical components may be damaged if terminals or connectors are connected or disconnected while the ignition switch is ON and current is present.

- When servicing the ignition system, always follow the steps in the troubleshooting sequence on page 14-2.
- The ignition timing does not normally need to be adjusted since the ignition Control Module (ICM) is factory preset.
- The ICM may be damaged if dropped. Also if the connector is disconnected when current is flowing, the excessive voltage may damage the module.
- A faulty ignition system is often related to poor connections. Check those connections before proceeding.
- Use spark plug of the correct heat range. Using spark plug with an incorrect heat range can damage the engine.

IGNITION SYSTEM/ALTERNATOR

SPECIFICATIONS

ITEM		SPECIFICATIONS	
Spark plug	Standard (NGK)		BR9EG
	Standard (DENSO)		W27ESR-V
	Optional (NGK)		BR9EV
	Optional (DENSO)		W27ESR-G
Spark plug gap		0.5 – 0.6 mm (0.020 – 0.024 in)	
Ignition coil resistance (at 20°C/68°F)	Primary	2000 – 2001:	0.1 – 0.3 Ω
		After 2001:	0.4 – 0.6 Ω
	Secondary with plug cap	2000 – 2001:	9 – 16 kΩ
		After 2001:	15 – 22 kΩ
	Secondary without plug cap	2000 – 2001:	4 – 8 kΩ
		After 2001:	10 – 17 kΩ
Ignition coil peak voltage		100 V minimum	
Ignition pulse generator resistance (at 20°C/68°F)		180 – 280 Ω	
Ignition pulse generator peak voltage		0.7 V minimum	
Alternator exciter coil resistance (at 20°C/68°F)	2000 – 2001:	9 – 25 Ω	
	After 2001:	Yellow – Blue: 120 – 180 Ω, Blue – White: 24 – 44 Ω	
Alternator exciter coil peak voltage	2000 – 2001:	100 V minimum	
	After 2001:	20 V minimum (Yellow – Blue and Blue – White)	
Ignition timing ("F" mark)	2000 – 2001:	31 ± 2° BTDC at 3,000 rpm	
	After 2001:	35 ± 2° BTDC at 3,000 rpm	

TORQUE VALUES

Flywheel nut	54 N•m (5.5 kgf•m, 40 lbf•ft)
Alternator cover screw (2000:)	2 N•m (0.2 kgf•m, 1.4 lbf•ft)

TOOLS

Peak voltage adapter	07HGJ – 0020100 (Not available in U.S.A.) with Commercially available digital multimeter (impedance 10 MΩ/DCV minimum)
Flywheel puller	07733 – 0010000 or 07933 – 0010000
Universal holder	07725 – 0030000

TROUBLESHOOTING

- Inspect the following before diagnosing the system.
 - Faulty spark plug
 - Loose spark plug cap or spark plug wire connection
 - Water got into the spark plug cap (affecting the ignition coil secondary voltage)

No spark at plug

Unusual condition		Probable cause (Check in numerical order)
Ignition coil primary voltage	Low peak voltage	<ol style="list-style-type: none"> 1. Incorrect peak voltage adaptor connections (System is normal if measured voltage is over the specifications with reverse connection). 2. The multimeter impedance is too low; below 10MΩ/DCV. 3. Cranking speed too slow. <ul style="list-style-type: none"> • Kickstarter is weak 4. The sample timing of the tester and measured pulse were not synchronized (System is normal if measured voltage is over the standard voltage at least once). 5. Poorly connected connectors or an open circuit in ignition system. 6. Faulty exciter coil (measure the peak voltage). 7. Faulty ignition coil. 8. Faulty ICM (when above No. 1 – 7 are normal).
	No peak voltage	<ol style="list-style-type: none"> 1. Incorrect peak voltage adaptor connections (System is normal if measured voltage is over the specifications with reverse connection). 2. Short circuit in engine stop switch wire 3. Faulty engine stop switch wire. 4. Loose or poorly connected ICM connectors. 5. An open circuit or loose connection in Green wire. 6. Faulty exciter coil (measure the peak voltage). 7. Faulty ignition pulse generator (measure the peak voltage). 8. Faulty ICM (when above No. 1 – 7 are normal).
	Peak voltage is normal, but no spark jumps at plug	<ol style="list-style-type: none"> 1. Faulty spark plug or leaking ignition coil secondary current ampere. 2. Faulty ignition coil.
Exciter coil	Low peak voltage	<ol style="list-style-type: none"> 1. The multimeter impedance is too low; below 10MΩ/DCV. 2. Cranking speed is too low. <ul style="list-style-type: none"> • Kickstarter is weak 3. The sampling timing of the tester and measured pulse were not synchronised (system is normal if measured voltage is over the standard voltage at least once). 4. Faulty ICM (when above No. 1 – 3 are normal).
	No peak voltage	<ol style="list-style-type: none"> 1. Faulty peak voltage adaptor. 2. Faulty exciter coil.
Ignition pulse generator	Low peak voltage	<ol style="list-style-type: none"> 1. The multimeter impedance is too low; below 10MΩ/DCV. 2. Cranking speed is too low. <ul style="list-style-type: none"> • Kickstarter is weak 3. The sampling timing of the tester and measured pulse were not synchronised (system is normal if measured voltage is over the standard voltage at least once). 4. Faulty ICM (when above No. 1 – 3 are normal).
	No peak voltage	<ol style="list-style-type: none"> 1. Faulty peak voltage adaptor. 2. Faulty ignition pulse generator.

With the ignition coil primary wire connected, connect the peak voltage adapter to the ignition coil.

CONNECTION: Black/Yellow (+) – Body ground (-)

Crank the engine with the kickstarter and read the ignition coil primary peak voltage.

PEAK VOLTAGE: 100V minimum

If the peak voltage is abnormal, check for an open circuit or poor connection in Black/Yellow wires. If defects are not found in the harness, refer to the troubleshooting chart on page 14-3.

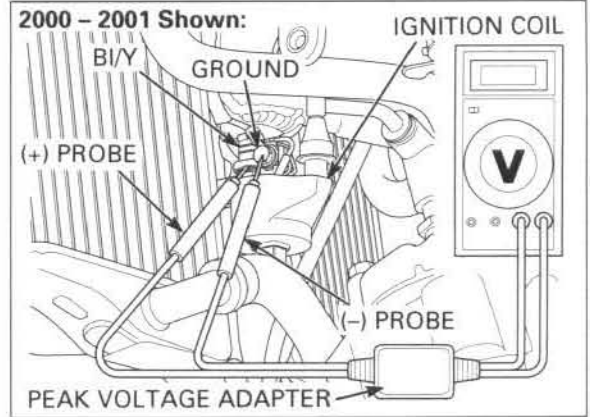

EXCITER COIL PEAK VOLTAGE

NOTE:

Check that the spark plug is installed correctly.

Remove the number plate (page 2-3).

Disconnect the ICM connector.
Connect the peak voltage adapter probes to the connector terminals of the wire harness side.

TOOLS:

Peak voltage adapter 07HGJ – 0020100
not available in U.S.A.

with commercially available digital multimeter
(impedance 10 M Ω /DCV minimum)

CONNECTION:

(2000 – 2001:) Blue (+) – White (-)
(After 2001:) Yellow (+) – Blue (-)
Blue (+) – White (-)

Crank the engine with the kickstarter and read the peak voltage.

PEAK VOLTAGE:

(2000 – 2001:) 100 V minimum
(After 2001:) 20 V minimum

If the peak voltage measured is abnormal, check the wire harness for open circuit or loose connection.

If the wire harness is normal, check each item in the troubleshooting chart. If all items are normal, the exciter coil is faulty. See page 14-8 for exciter coil replacement.

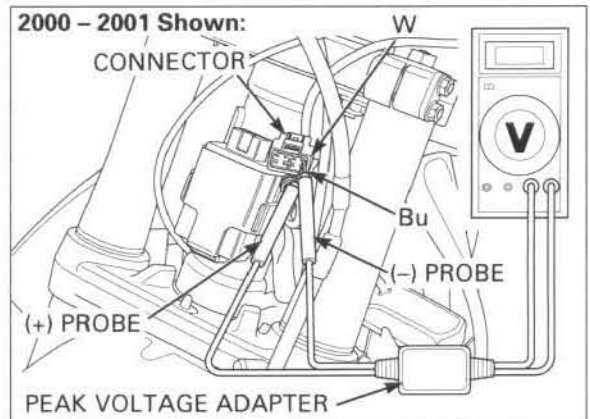
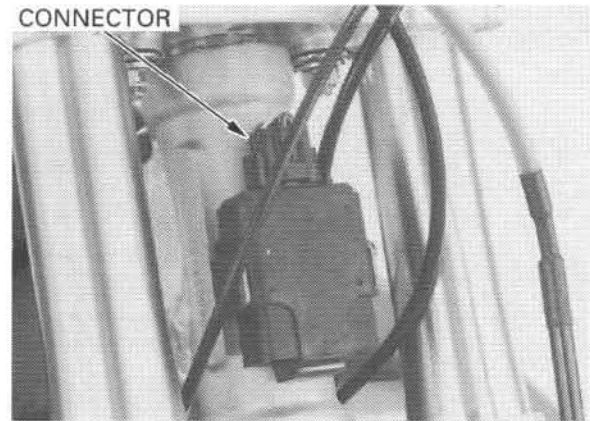

IGNITION COIL

INSPECTION

Remove the left radiator shroud (page 2-3).
 Remove the spark plug cap.
 Disconnect the ignition coil primary wire.
 Measure the ignition primary coil resistance between the primary terminal and body ground.

STANDARD:
 (2000 – 2001:) 0.1 – 0.3 Ω (20°C/68°F)
 (After 2001:) 0.4 – 0.6 Ω (20°C/68°F)

If the resistance is out of range, replace the ignition coil.

Measure the ignition secondary coil resistance between the primary terminal and plug cap.

STANDARD:
 (2000 – 2001:) 9 – 16 kΩ (20°C/68°F)
 (After 2001:) 15 – 22 kΩ (20°C/68°F)

If the resistance is out of range, remove the spark plug cap and measure the ignition secondary coil resistance between the primary terminal and spark plug wire.

STANDARD:
 (2000 – 2001:) 4 – 8 kΩ (20°C/68°F)
 (After 2001:) 10 – 17 kΩ (20°C/68°F)

If resistance is out of range, replace the ignition coil.

REMOVAL/INSTALLATION

Remove the left radiator shroud (page 2-3).
 Remove the spark plug cap.
 Disconnect the ignition coil primary wire.
 Remove the bolts and ignition coil.

Installation is in the reverse order of removal.

2000 – 2001 Shown
 PRIMARY TERMINAL

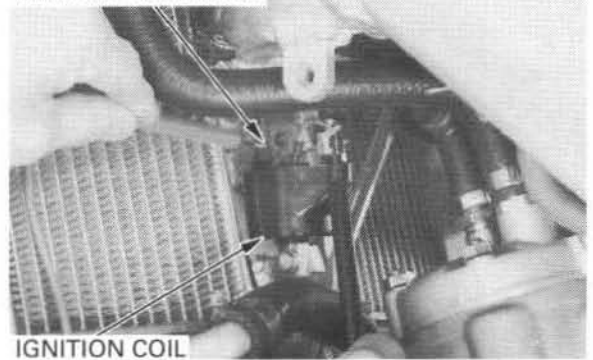

IGNITION COIL

2000 – 2001 Shown:

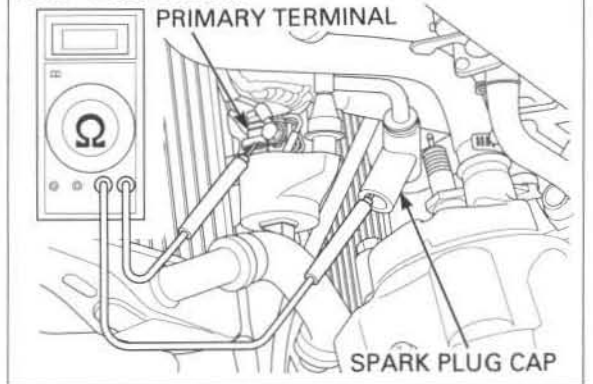

2000 – 2001 Shown:

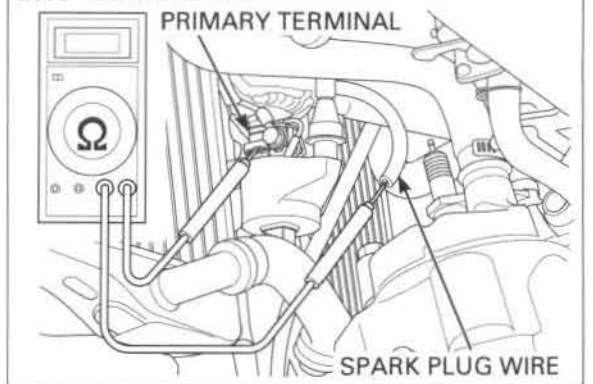

2000 – 2001: Shown
 PRIMARY WIRE

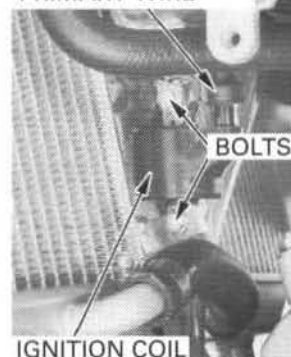

IGNITION COIL

After 2001 Shown:
 PRIMARY WIRE



IGNITION COIL

BOLTS

EXCITER COIL

INSPECTION

Remove the number plate (page 2-3).

Disconnect the ICM connector.
Measure the resistance between the Blue and White terminals of the wire harness side.

STANDARD:

(2000 – 2001:) 9 – 25 Ω (20°C/68°F)

(After 2001:)

Yellow – Blue: 120 – 180 Ω (20°C/68°F)

Blue – White: 24 – 44 Ω (20°C/68°F)

If the resistance is out of range, replace the stator (see below).

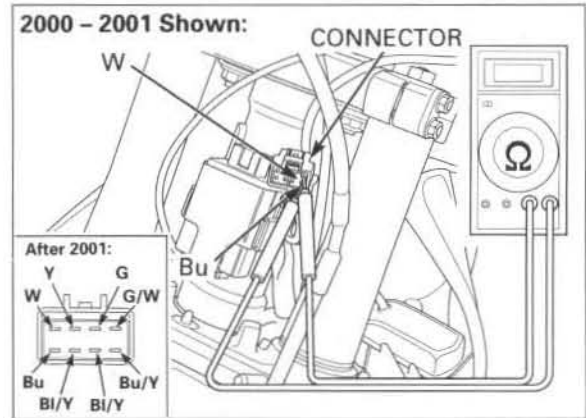

IGNITION PULSE GENERATOR

INSPECTION

Remove the number plate (page 2-3).

Disconnect the ICM connector.
Measure the resistance between the Blue/Yellow and Green/White terminals of the wire harness side.

STANDARD: 180 – 280 Ω (20°C/68°F)

If resistance is out of range, replace the stator (see below).

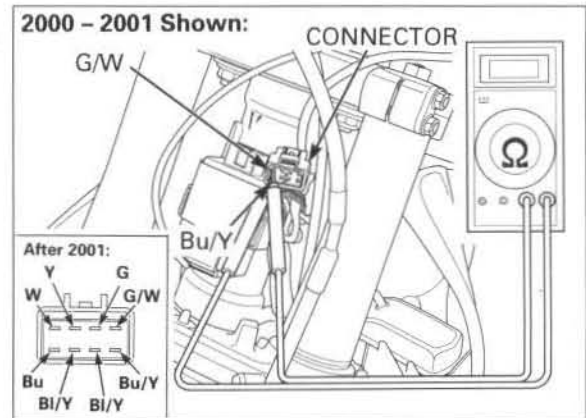

ALTERNATOR

REMOVAL

Remove the number plate (page 2-3).
Disconnect the ignition control module connector.

Disconnect the engine stop switch connectors.

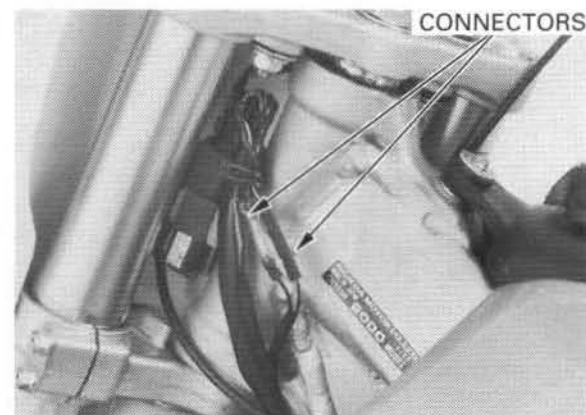
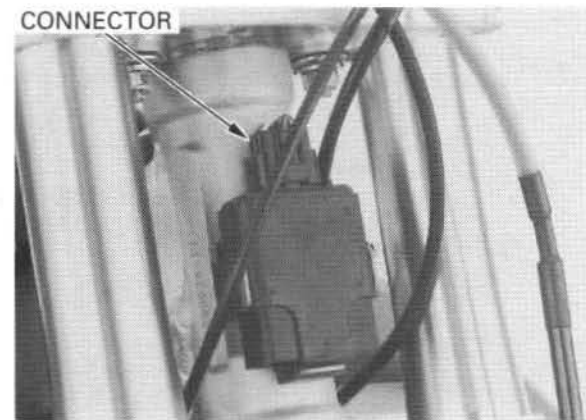

Remove the left radiator shroud (page 2-3).
Disconnect the ignition coil connector and ground
cable eyelet.

2000 – 2001 Shown
GROUND CABLE

After 2001 Shown:
CONNECTOR

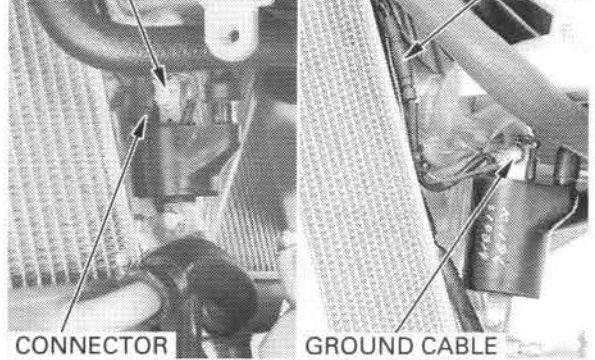

2000:
Remove the screws, alternator cover and rubber
gasket.

SCREWS

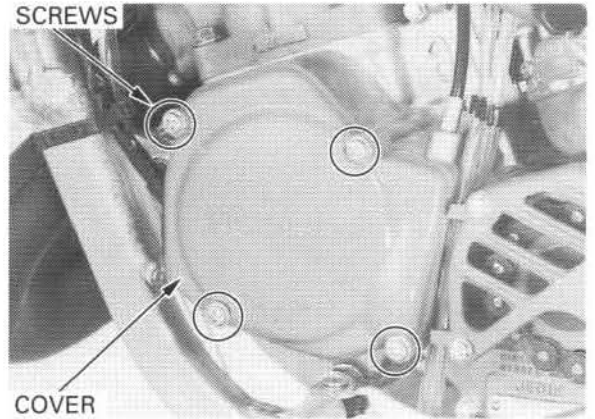

After 2000:
Remove the bolts and alternator cover.

BOLTS

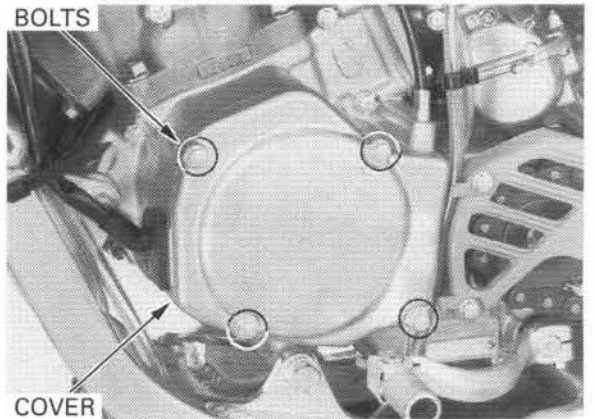

Remove the gasket.

GASKET

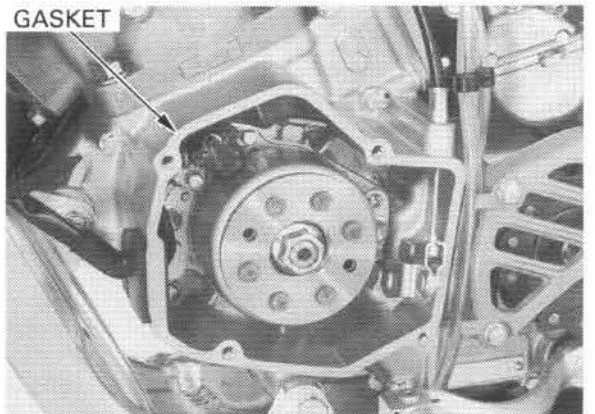

Hold the flywheel with the universal holder then remove the nut and washer.

TOOL:

Universal holder 07725 - 0030000

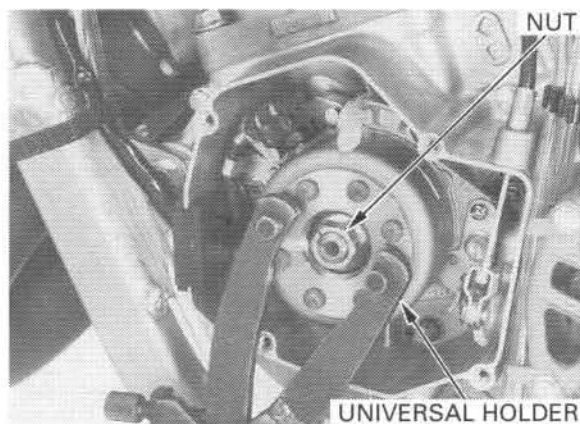

Remove the flywheel using the flywheel puller.

TOOL:

Flywheel puller 07733 - 0010000 or
07933 - 0010000

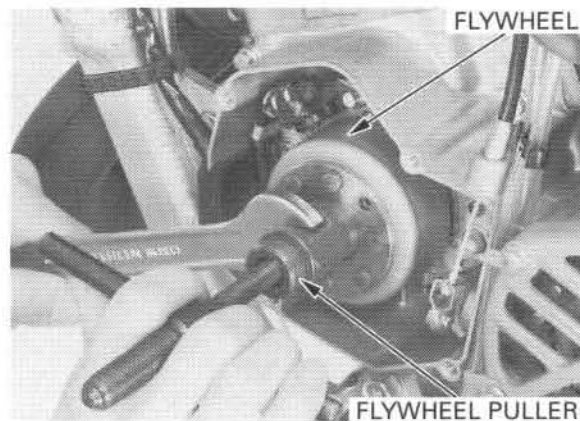

Remove the grommet, woodruff key, bolts and stator.

INSTALLATION

Install the woodruff key to the groove on the crankshaft.

Install the stator and tighten the bolts securely.

Install the grommet to the groove on the left crankcase.

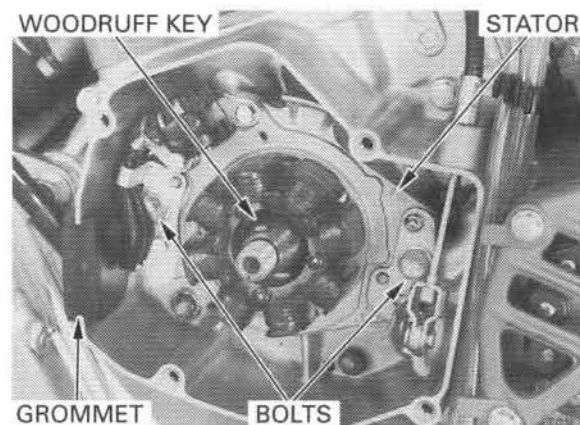

Install the flywheel to the crankshaft by aligning the groove on the flywheel and woodruff key.

Install the washer and nut.

Hold the flywheel with the special tool and tighten the nut to the specified torque.

TOOL:

Universal holder 07725 - 0030000

TORQUE: 54 N·m (5.5 kgf·m, 40 lbf·ft)

NOTE:

When you replaced the flywheel, stator or ICM, check and adjust the ignition timing (see below).

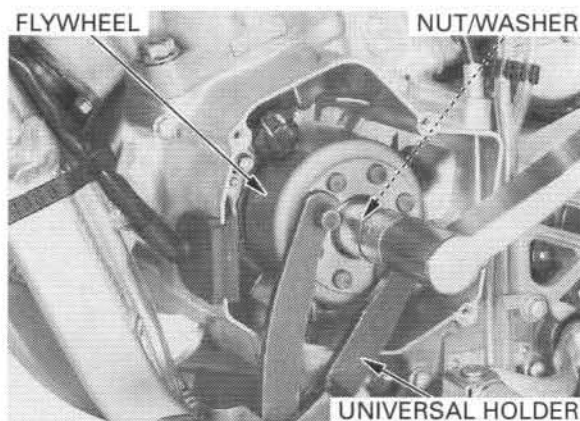

2000:

Check that the rubber gasket is in good condition.
Install the rubber gasket to the alternator cover.

Install the alternator cover and tighten the screws to the specified torque.

TORQUE: 2 N•m (0.2 kgf•m, 1.4 lbf•ft)

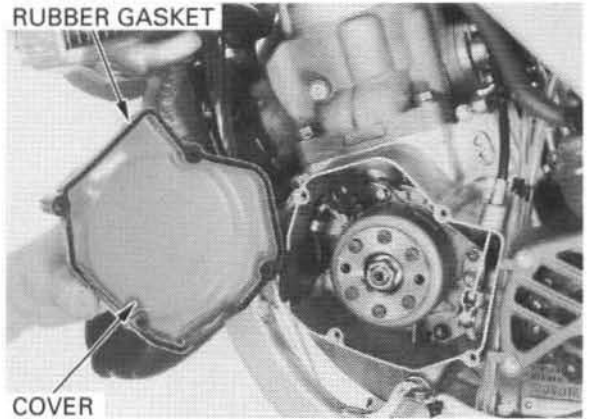

After 2000:

Install the new gasket.

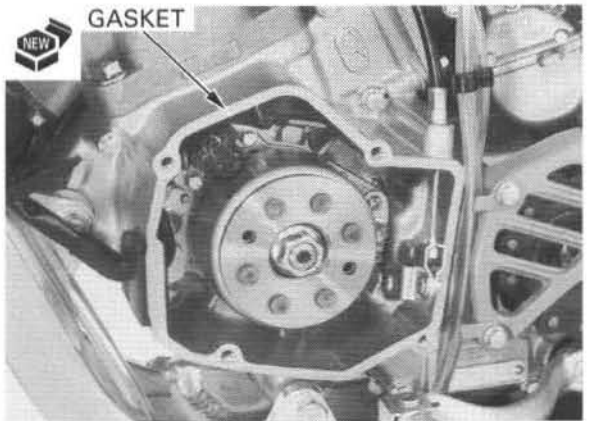

Install the alternator cover and tighten the bolts.

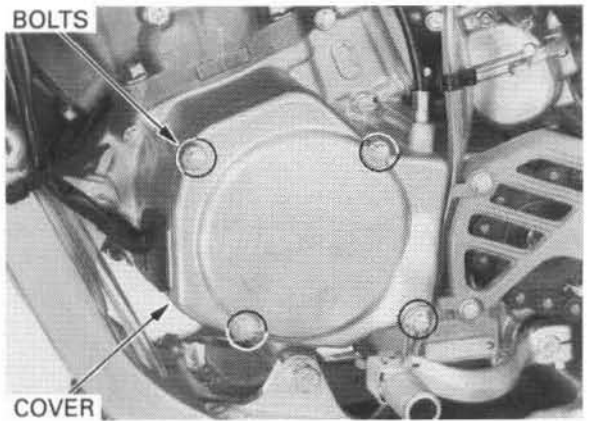

Connect the ignition coil connector and ground cable eyelet.
Install the left radiator shroud (page 2-3).

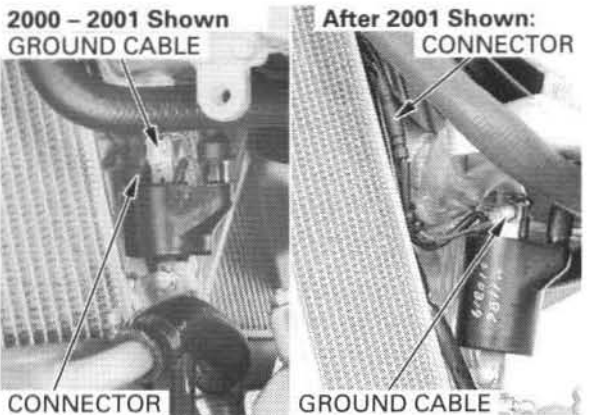

IGNITION SYSTEM/ALTERNATOR

Connect the engine stop switch connectors.

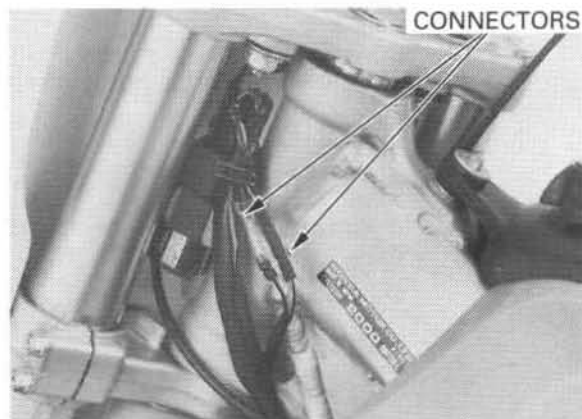

Connect the ignition control module connector.
Install the number plate (page 2-3).

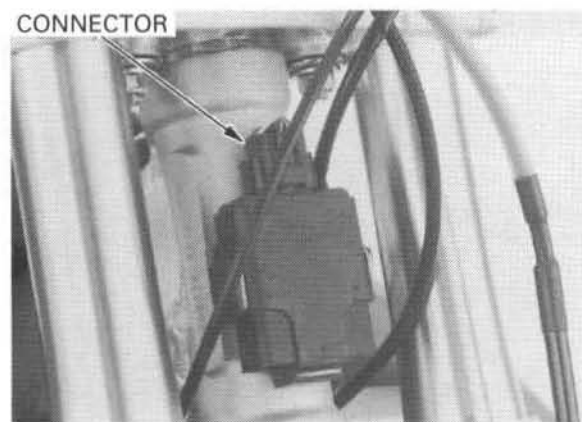

IGNITION TIMING

⚠ WARNING

If the engine must be running to do some work, make sure the area is well ventilated. Never run the engine in an enclosed area. The exhaust contains poisonous carbon monoxide gas that may cause loss of consciousness and may lead to death.

NOTE:

The ignition timing is factory preset and need only be checked when an electrical system component is replaced.

Warm up the engine to normal operating temperature.
Stop the engine.

Remove the alternator cover.

Check that the stator index mark is aligned with the index mark on the crankcase.

Attach the timing light and tachometer.
Start the engine and hold it at 3,000 rpm while pointing the timing light towards the index mark.

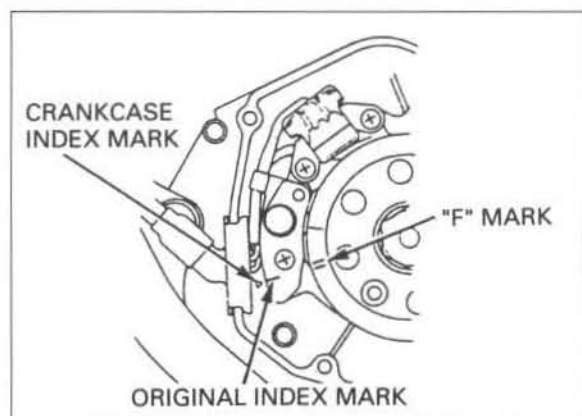
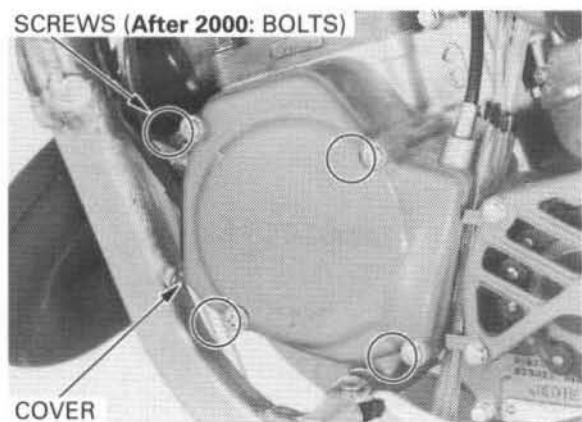

If the stator's original index mark aligns between the "F" marks, the engine is timed correctly. Remove the testing equipment and reassemble the motorcycle.

If the stator's original index mark does not align between the "F" marks, scribe a temporary index mark on the stator setting plate that will align between the "F" marks at 3,000 rpm. Stop the engine and do the following:

NOTE:

- This procedure is to be done after replacing the ICM, ignition pulse generator/stator assembly or flywheel.
- If you have checked the ignition timing as a troubleshooting method and the marks did not align, inspect the ICM, ignition pulse generator and stator, before performing this procedure.

Remove the stator mounting bolts, setting plate screw and setting plate. Elongate the setting plate mounting bolt hole, then reinstall it with its temporary index mark aligned with the index mark on the crankcase.

Install and tighten the stator mounting bolts and setting plate screw.

Recheck the ignition timing. The stator setting plate index mark should now align between the "F" marks on the flywheel.

Repeat the steps if the ignition timing is not correct.

Grind off the old index mark.

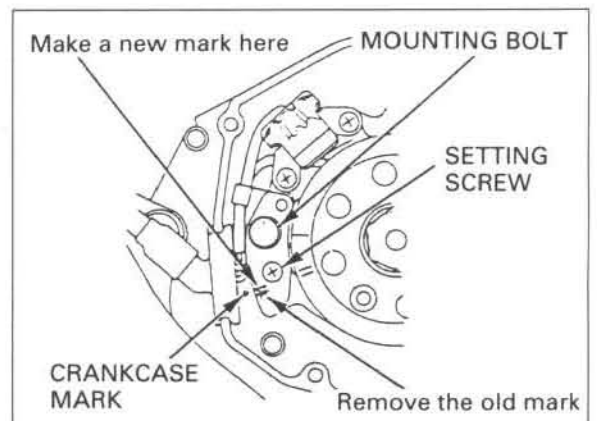
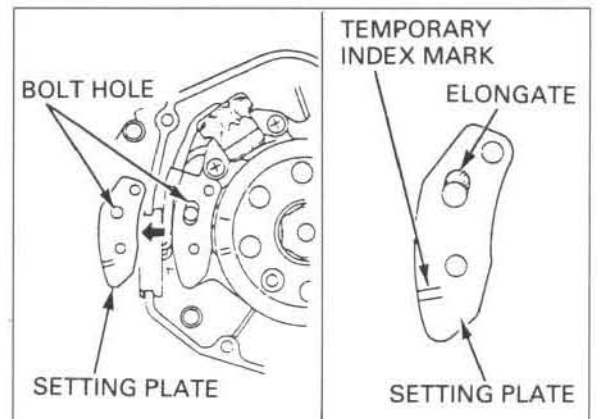
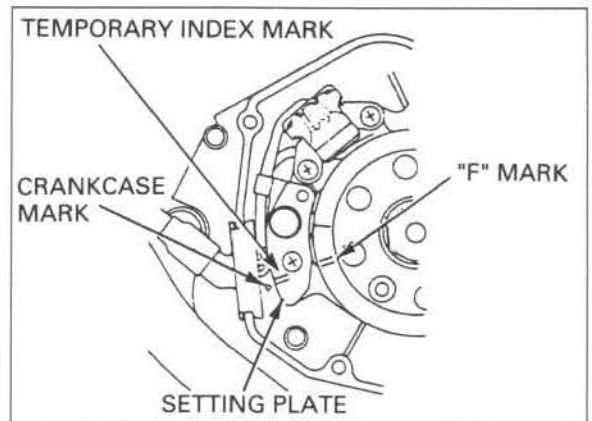

ENGINE STOP SWITCH

INSPECTION

Disconnect the engine stop switch connectors. Check the engine stop switch for continuity with the switch button pressed. There should be no continuity when the button is not pushed.

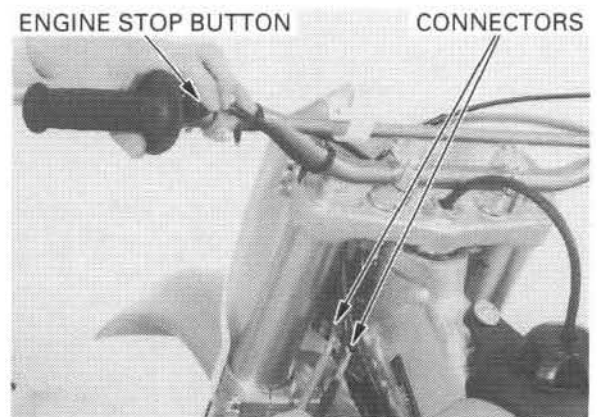

MEMO



15. WIRING DIAGRAMS

2000 - 2001:

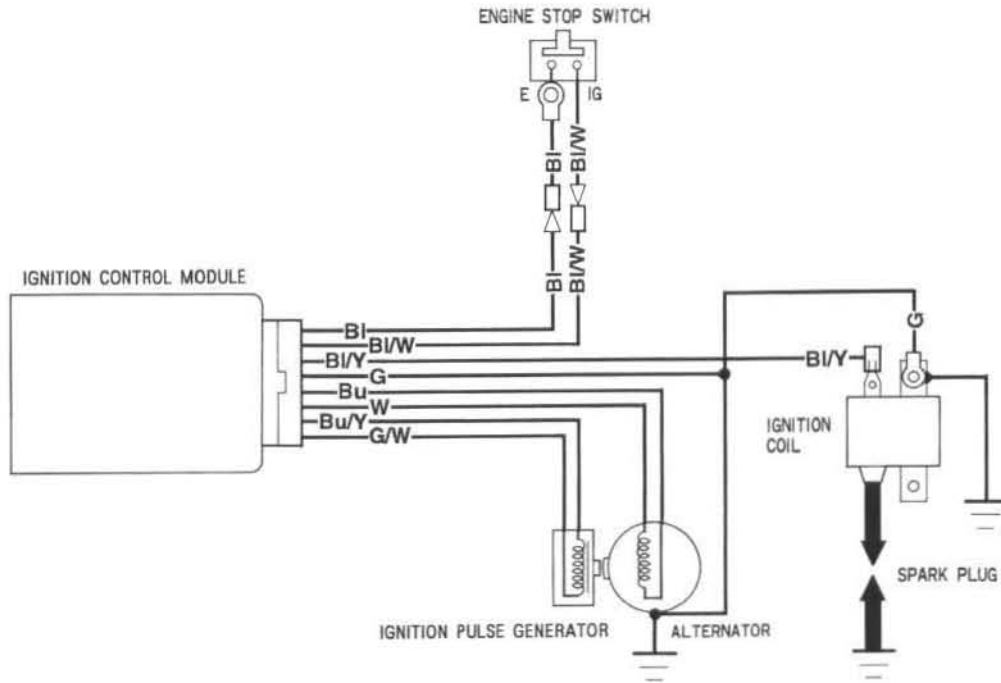

ENGINE STOP SWITCH CONTINUITY

	IG	E
FREE		
PUSH	○	○
COLOR	BI/W	G

- | | | | | | |
|----|-------|--------|----|-------|-------------|
| BI | | BLACK | Br | | BROWN |
| Y | | YELLOW | O | | ORANGE |
| Bu | | BLUE | Lb | | LIGHT BLUE |
| G | | GREEN | Lg | | LIGHT GREEN |
| R | | RED | P | | PINK |
| W | | WHITE | Gr | | GRAY |

0030Z- KZ 4 - J200

WIRING DIAGRAMS

After 2001:

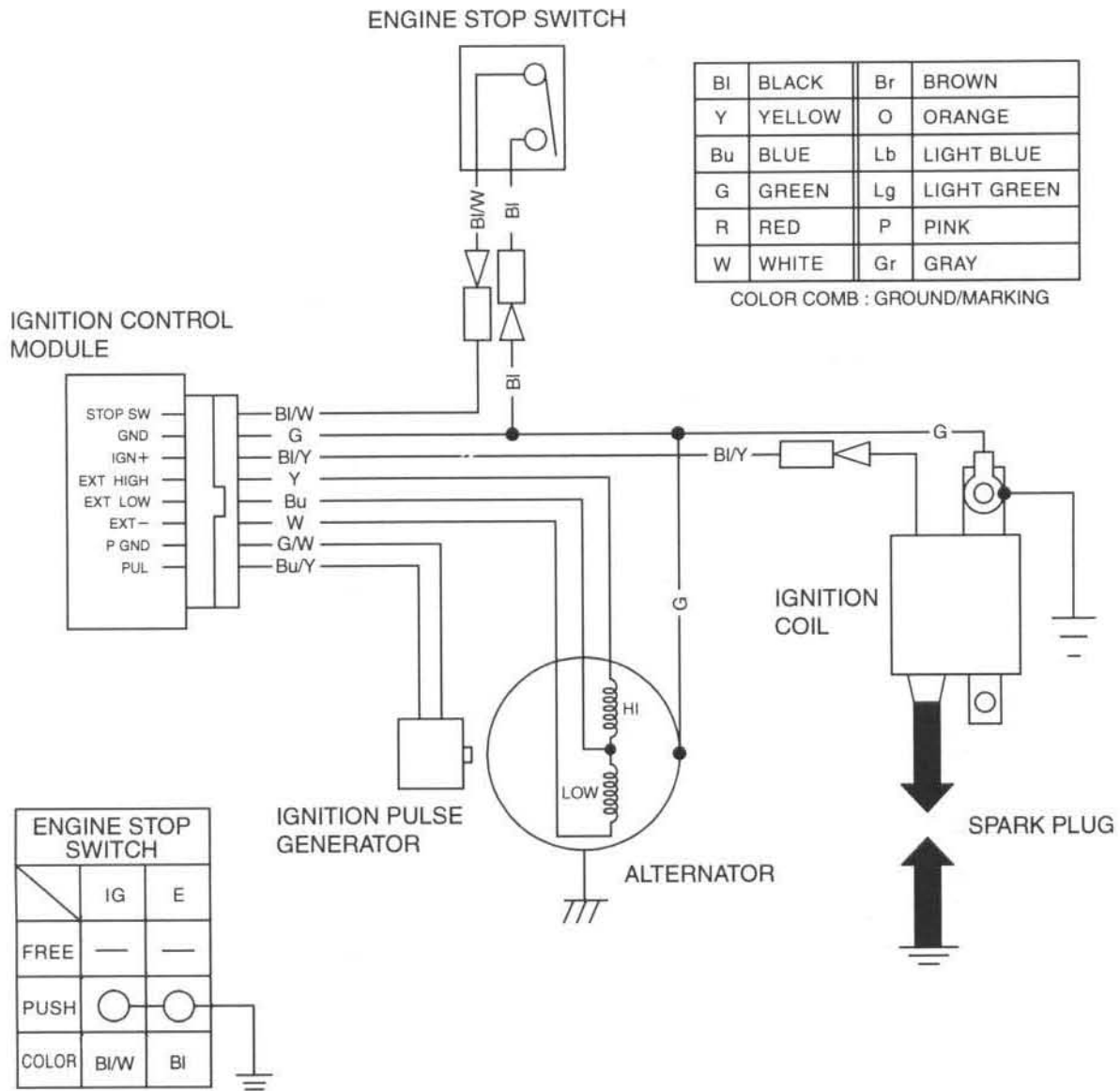

16. TECHNICAL FEATURES

RC (Radical Combustion) VALVE

To increase the output of 2-cycle engines, the standard practice is to set an ideal cylinder port timing and increase the intake pumping efficiency of the crankcase chamber for the intake air by using the pulsation of the exhaust gas as it passes through the exhaust chamber.

To obtain an extensive increase in output from 2-cycle engines, it is necessary to change the exhaust timing according to the low and high speeds of the engine.

In this engine, a valve is provided at the upper end of the exhaust port in the cylinder. The valve adjusts the exhaust timing according to engine speed, providing greater power output.

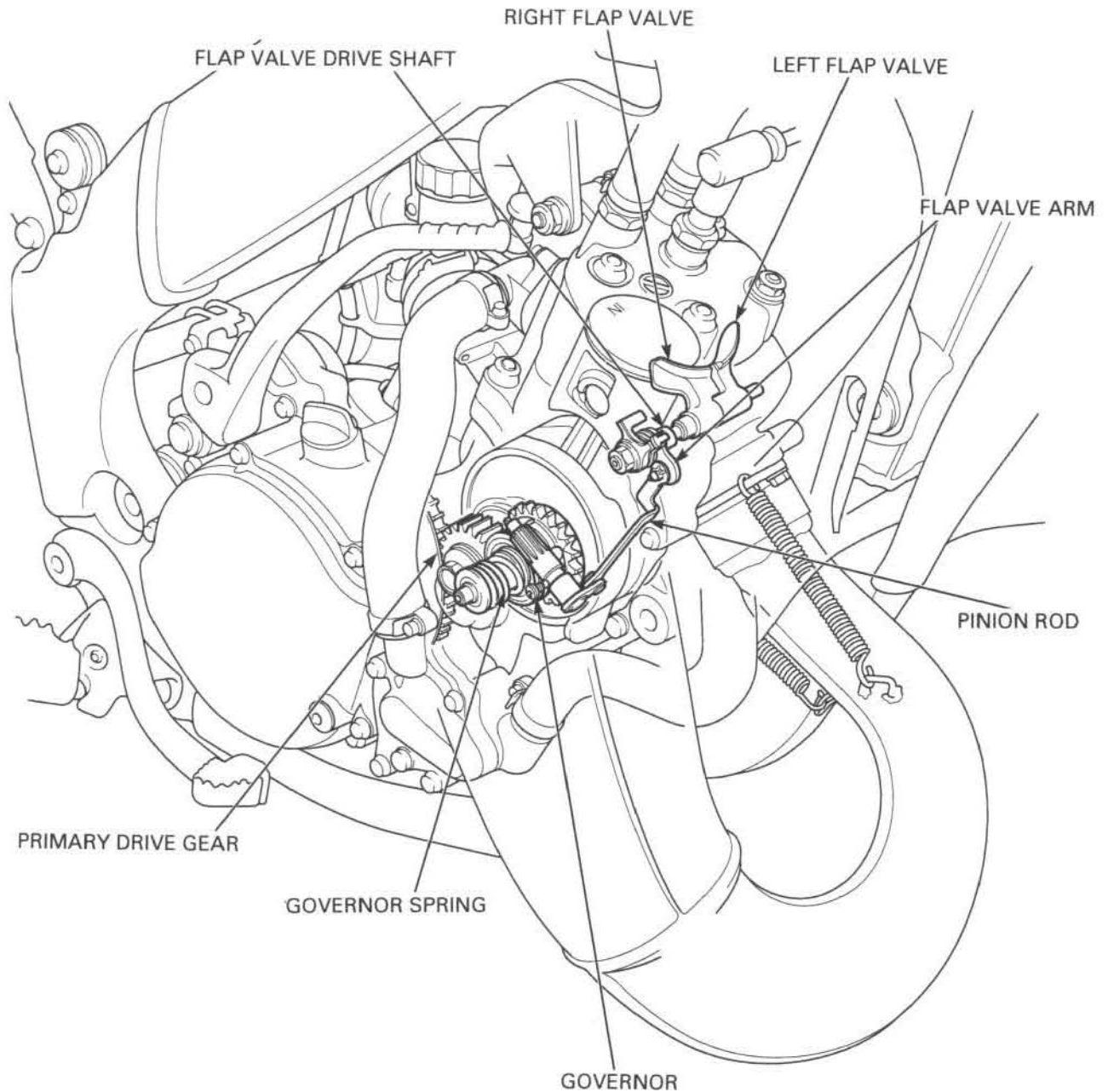

TECHNICAL FEATURES

The system consists roughly of a governor utilizing a steel ball, pinion rod, valve arm, drive shaft and flap valve.

When the engine is running at low speed, the governor spring which is connected through the pinion rod, flap valve arm and flap valve drive shaft causes the flap valve to lower.

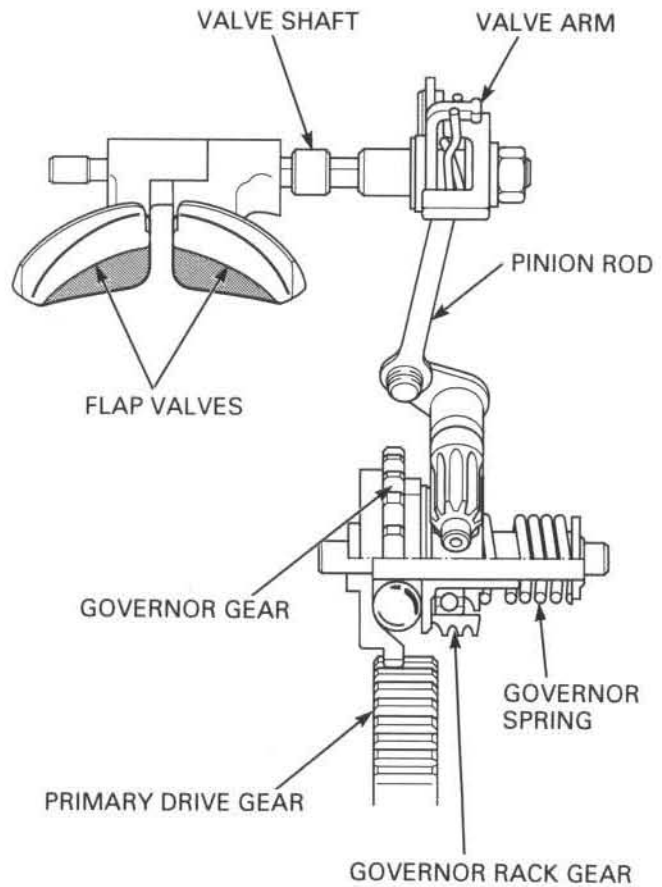

As the engine picks up speed, and its speed exceeds the operating speed of the governor, the steel ball is flung radially outward, compressing the governor spring.

As this takes place, the ring rack moves, causing the pinion gear to rotate.

Rotation of the pinion gear is then conveyed to the flap valve through the pinion rod, flap valve arm and flap valve drive shaft there by opening the flap valve.

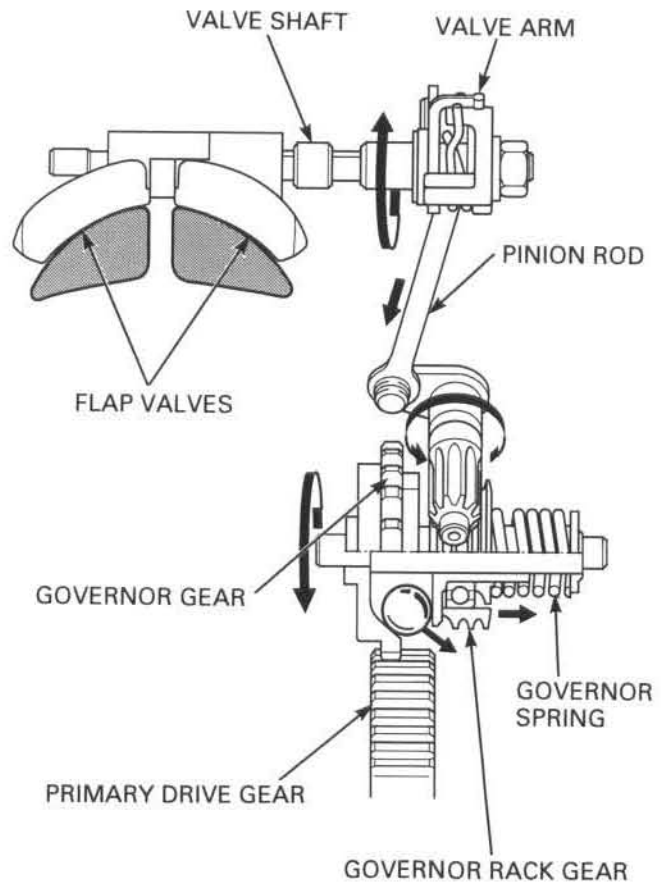

17. TROUBLESHOOTING

ENGINE DOES NOT START OR IS HARD TO START	17-1	POOR PERFORMANCE AT HIGH SPEED	17-4
ENGINE LACKS POWER	17-2	POOR HANDLING	17-4
POOR PERFORMANCE AT LOW AND IDLE SPEEDS	17-3		

ENGINE DOES NOT START OR IS HARD TO START

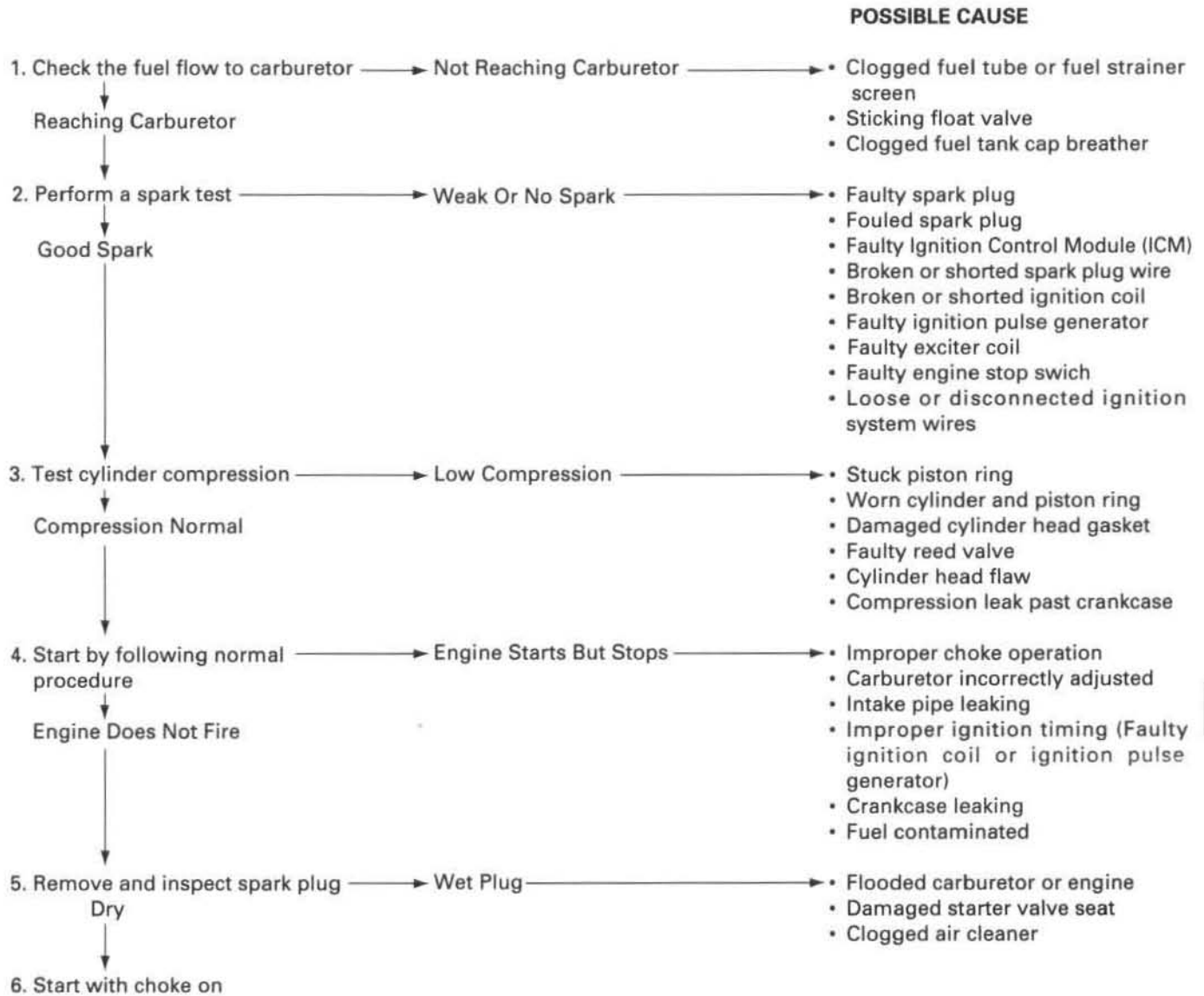

ENGINE LACKS POWER

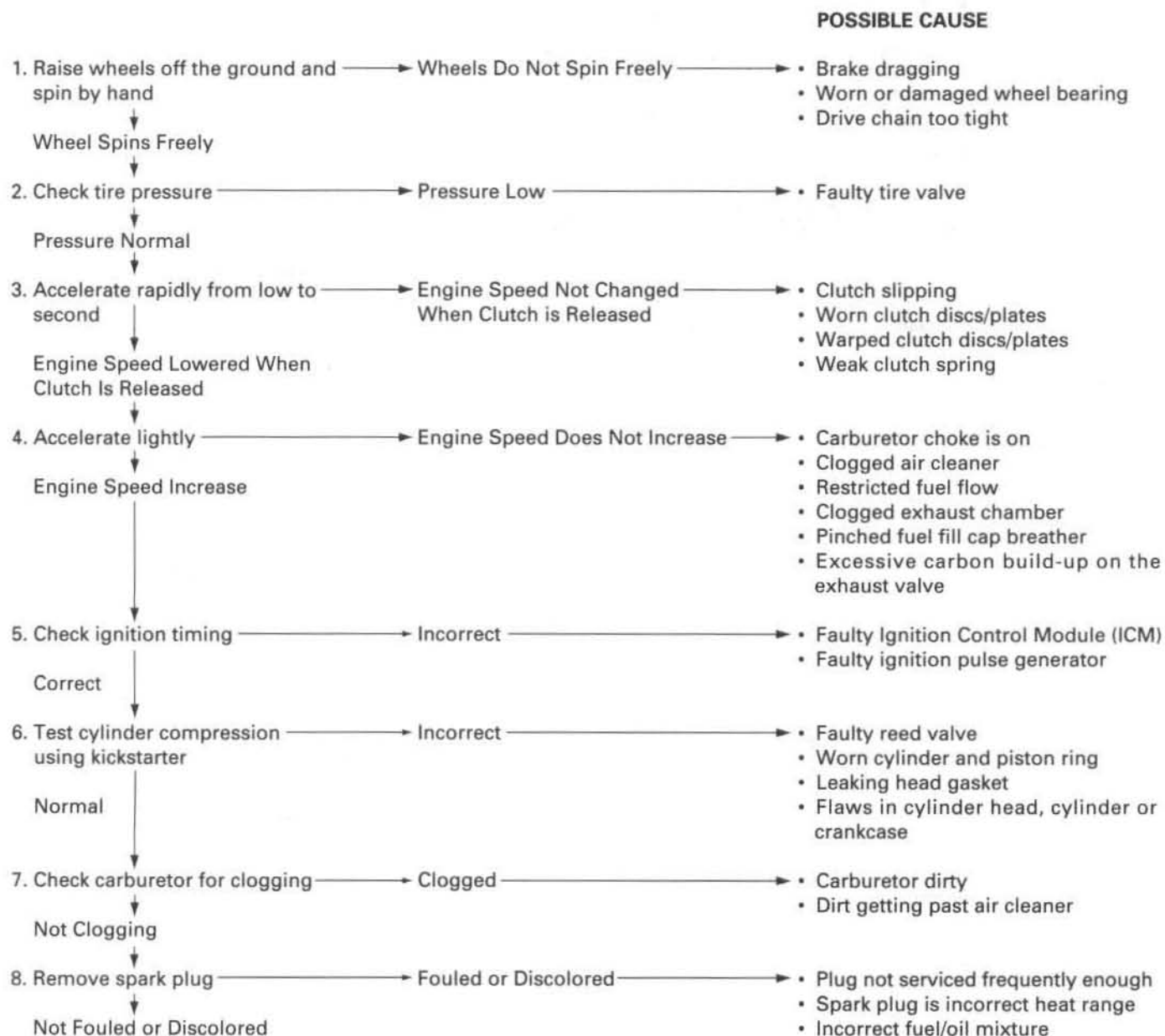

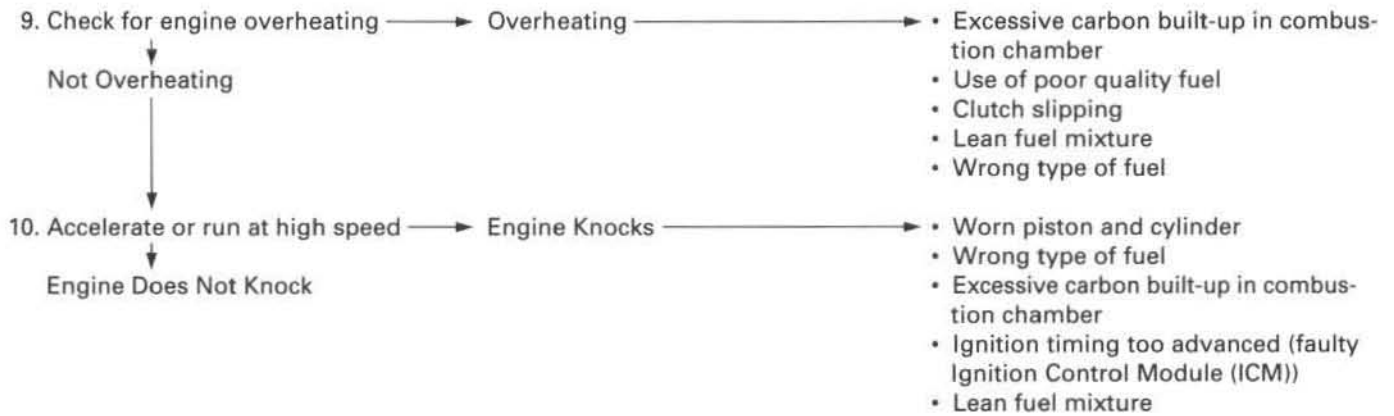

POOR PERFORMANCE AT LOW AND IDLE SPEED

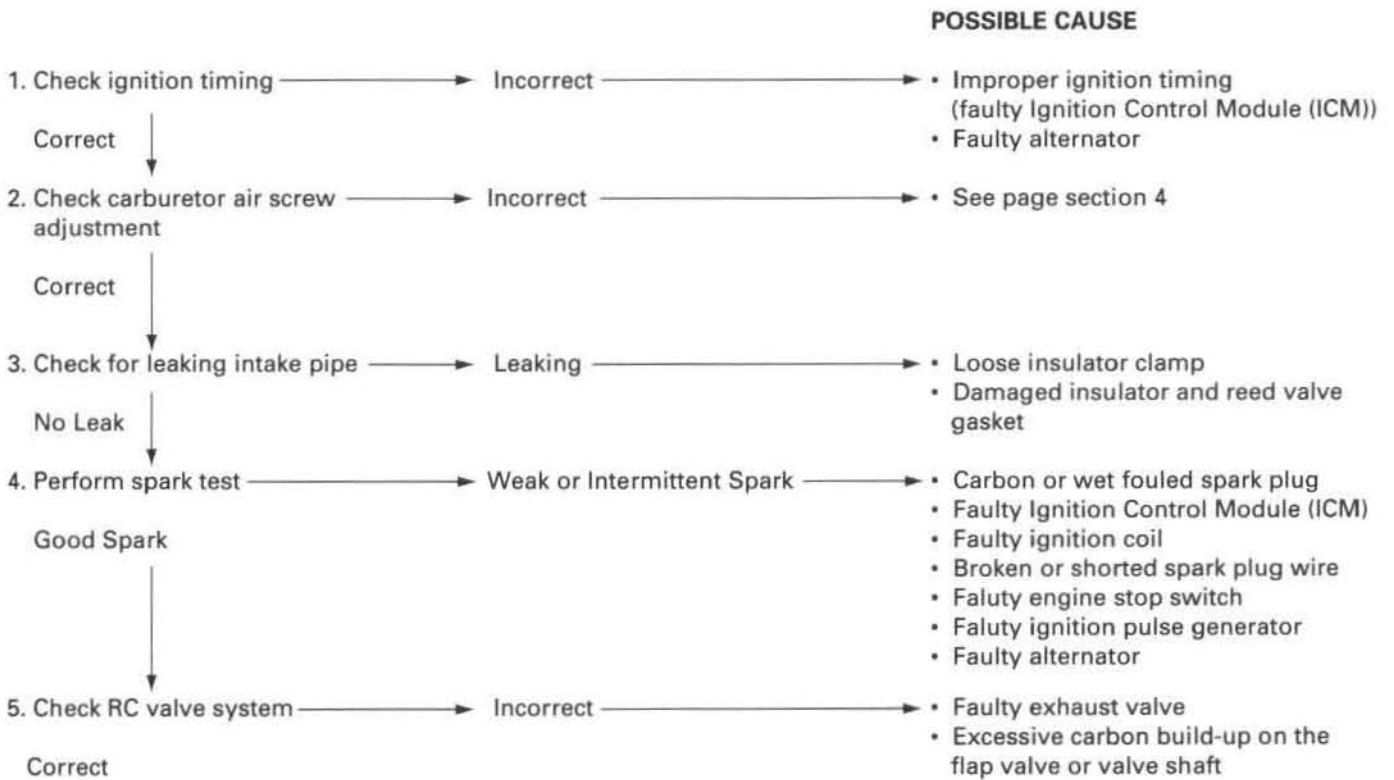

TROUBLESHOOTING

POOR PERFORMANCE AT HIGH SPEED

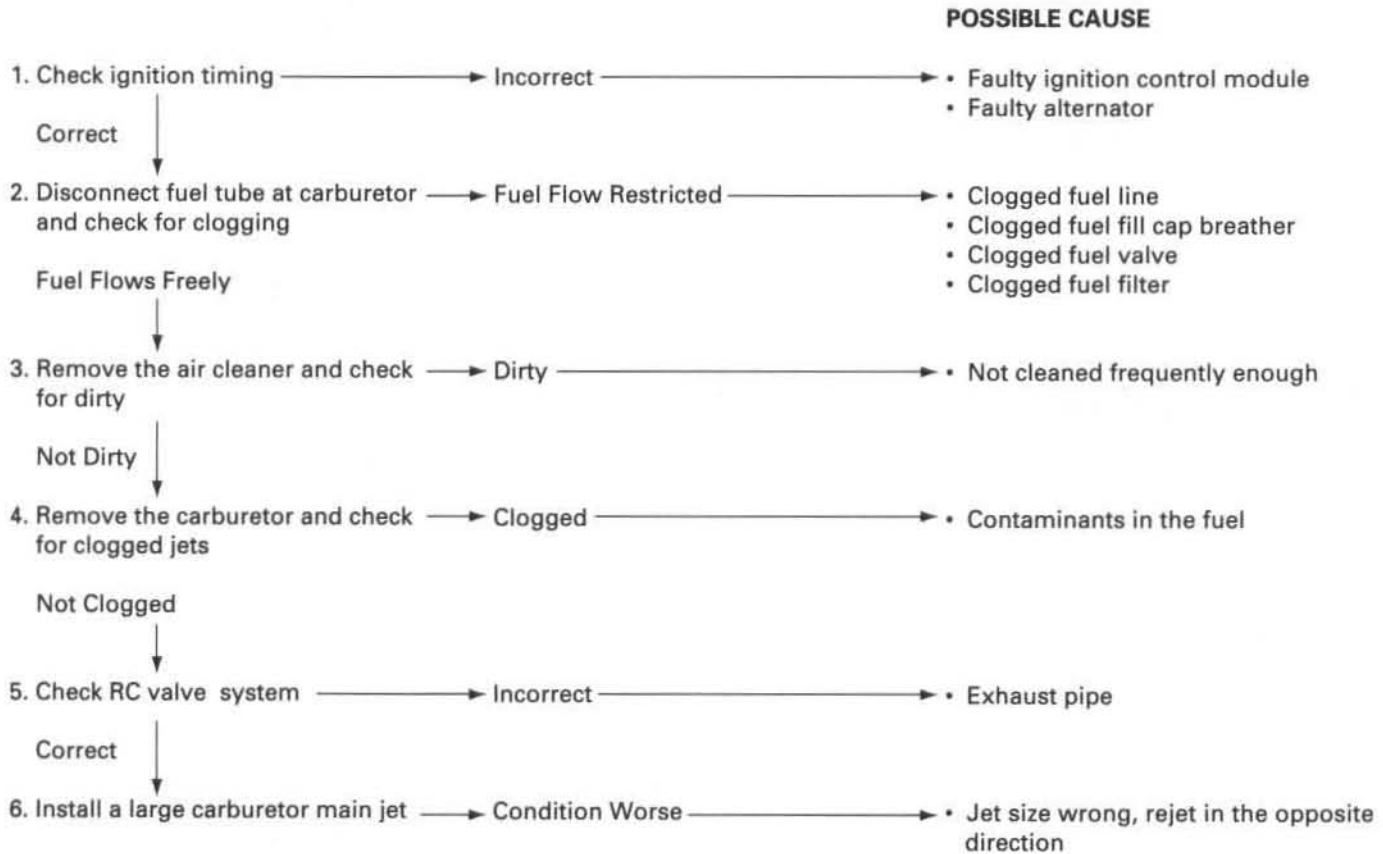

POOR HANDLING

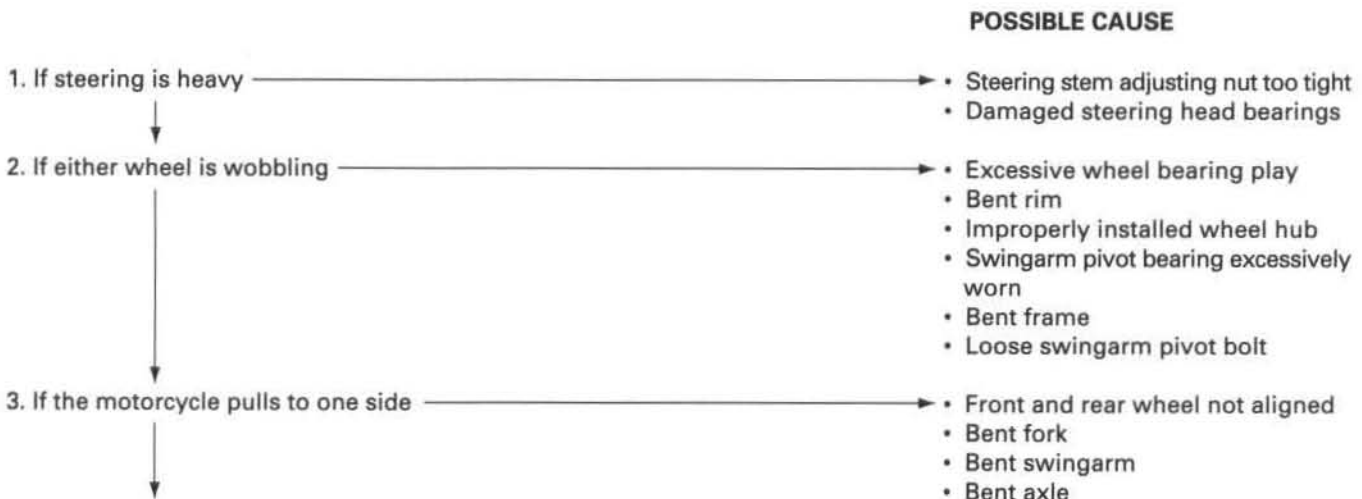

NOTE:

- For the recommendations 4 through 11, to be most useful, the motorcycle must be adjusted as follows:
 Forks – compression damping at standard position, at standard fork oil quantity and viscosity, and air pressure zero.
 Shock – nitrogen pressure 142 psi, compression and rebound damping standard position, and spring preload adjusted so the bikes sags with rider seated – see Owner's Manual for spring preload adjustment.
- Make only one change at a time, then test ride and evaluate the difference before making further adjustments. The solutions are given in the preferred sequence of adjustment.

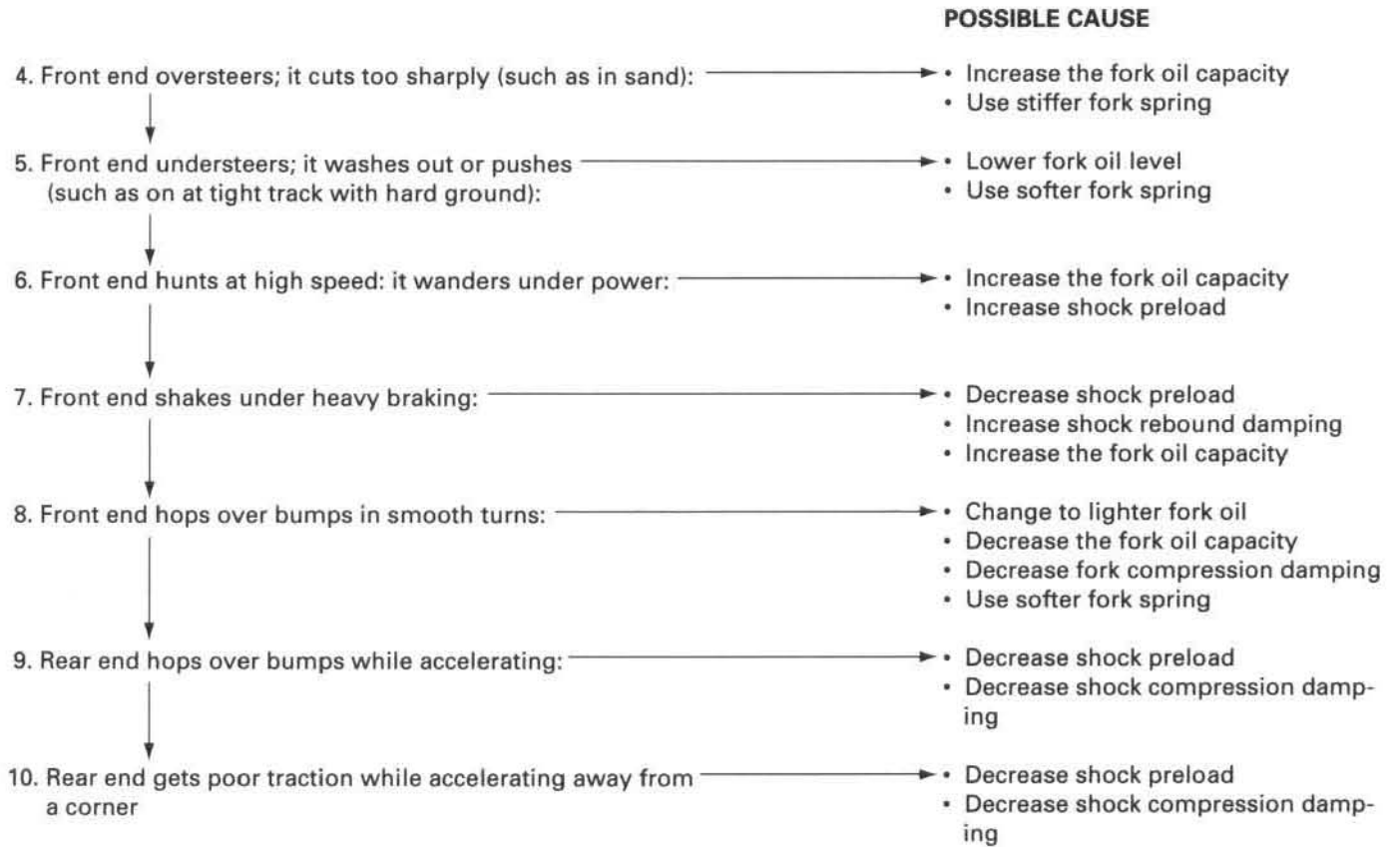

MEMO

RIDE RED

18. INDEX

AIR CLEANER	3-5	POOR HANDLING	17-4
AIR CLEANER HOUSING	4-23	POOR PERFORMANCE AT HIGH SPEED	17-4
ALTERNATOR	14-8	POOR PERFORMANCE AT LOW AND IDLE SPEEDS	17-3
BRAKE FLUID	3-13	RADIATOR	5-5
BRAKE FLUID REPLACEMENT/AIR BLEEDING	13-4	RADIATOR COOLANT	3-8
BRAKE PAD WEAR	3-14	SHROUD	2-3
BRAKE PAD/DISK	13-7	REAR BRAKE CALIPER	13-22
BRAKE PEDAL	13-22	REAR MASTER CYLINDER	13-12
BRAKE SYSTEM	3-14	REAR WHEEL	12-4
CABLE & HARNESS ROUTING	1-20	REED VALVE	4-21
CARBURETOR ADJUSTMENT, MAJOR	4-5	RIGHT CRANKCASE COVER	9-3
MINOR	4-4	SEAT	2-2
CARBURETOR ASSEMBLY/INSTALLATION	4-14	SERVICE INFORMATION	
REMOVAL/DISASSEMBLY	4-9	(CLUTCH/KICKSTARTER/GEARSHIFT LINKAGE)	9-1
CLUTCH	9-4	(COOLING SYSTEM)	5-1
CLUTCH SYSTEM	3-15	(CRANKCASE/CRANKSHAFT/TRANSMISSION)	10-1
CONTROL CABLES	3-16	(CYLINDER HEAD/CYLINDER/PISTON)	7-1
COOLANT REPLACEMENT	5-4	(ENGINE REMOVAL/INSTALLATION)	6-1
COOLING SYSTEM	3-8	(FRAME/BODY PANELS/EXHAUST SYSTEM)	2-1
CRANKCASE ASSEMBLY	10-16	(FRONT WHEEL/SUSPENSION/STEERING)	11-1
BEARING REPLACEMENT	10-9	(FUEL SYSTEM)	4-2
SEPARATION	10-4	(HYDRAULIC BRAKE)	13-2
CRANKSHAFT INSTALLATION	10-13	(IGNITION SYSTEM/ALTERNATOR)	14-1
REMOVAL	10-8	(MAINTENANCE)	3-1
CYLINDER HEAD	7-3	(RC VALVE)	8-1
CYLINDER HEAD DECARBONIZING	3-8	(REAR WHEEL/SUSPENSION)	12-1
CYLINDER, PISTON	7-5	SERVICE RULES	1-2
DRIVE CHAIN	3-10	SHOCK ABSORBER	12-10
DRIVE CHAIN ROLLERS	3-12	SHOCK LINKAGE	12-26
SLIDERS	3-12	SIDE COVERS	2-2
DRIVE/DRIVEN SPROCKETS	3-13	SPARK PLUG	3-6
ENGINE DOES NOT START OR IS HARD TO START	17-1	SPECIFICATIONS	1-4
ENGINE INSTALLATION	6-4	STEERING HEAD BEARINGS	3-19
ENGINE LACKS POWER	17-2	STEERING STEM	11-29
ENGINE REMOVAL	6-2	SUB-FRAME	2-4
ENGINE STOP SWITCH	14-12	SUSPENSION	3-17
EXCITER COIL	14-8	SWINGARM	12-31
EXHAUST DEPOSIT DRAINING	8-2	SWINGARM/SHOCK LINKAGE	3-18
EXHAUST PIPE	2-6	SYSTEM TESTING	5-3
EXHAUST VALVE	8-2	TECHNICAL FEATURES	16-1
EXHAUST VALVE DECARBONIZING	3-9	THROTTLE OPERATION	3-5
EXPANSION CHAMBER/SILENCER	3-16	TOOLS	1-16
FORK	11-9	TORQUE VALUES	1-13
FRONT BRAKE CALIPER	13-16	TRANSMISSION ASSEMBLY	10-14
FRONT MASTER CYLINDER	13-9	DISASSEMBLY	10-6
FRONT WHEEL	11-4	TRANSMISSION OIL	3-9
FUEL TANK	2-5	TROUBLESHOOTING	
GEARSHIFT LINKAGE	9-15	(CLUTCH/KICKSTARTER/GEARSHIFT LINKAGE)	9-2
GENERAL SAFETY	1-1	(COOLING SYSTEM)	5-2
GOVERNOR/VALVE LINKAGE	8-5	(CRANKCASE/CRANKSHAFT/TRANSMISSION)	10-3
HANDLEBAR	11-24	(CYLINDER HEAD/CYLINDER/PISTON)	7-2
ICM (IGNITION CONTROL MODULE)	14-6	(FRAME/BODY PANELS/EXHAUST SYSTEM)	2-1
IGNITION COIL	14-7	(FRONT WHEEL/SUSPENSION/STEERING)	11-3
IGNITION PULSE GENERATOR	14-8	(FUEL SYSTEM)	4-3
IGNITION SYSTEM INSPECTION	14-4	(HYDRAULIC BRAKE)	13-3
IGNITION TIMING	14-11	(IGNITION SYSTEM/ALTERNATOR)	14-2
KICKSTARTER	9-12	(RC VALVE)	8-1
LUBRICATION & SEAL POINTS	1-16	(REAR WHEEL/SUSPENSION)	12-3
MAINTENANCE SCHEDULE	3-3	TUNING FOR SPECIAL CONDITIONS	4-8
MODEL IDENTIFICATION	1-3	WATER PUMP	5-7
NUMBER PLATE	2-3	WHEELS/TIRES	3-19
NUTS, BOLTS, FASTENERS	3-19	WIRING DIAGRAMS	15-1
OPTIONAL PARTS	1-26		