



Includes:

- Important Safety Information
- Operating Instructions
- Maintenance and Storage

Super SHERPA Motorcycle

OWNER'S MANUAL

Quick Reference Guide

This Quick Reference Guide will assist you in finding the information you're looking for.

GENERAL INFORMATION

HOW TO RIDE THE MOTORCYCLE

SAFE OPERATION

MAINTENANCE AND ADJUSTMENT

STORAGE

TROUBLESHOOTING GUIDE

A Table of Contents is included after the Foreword.

Whenever you see the symbols shown below, heed their instructions! Always follow safe operating and maintenance practices.

 **WARNING**

This warning symbol identifies special instructions or procedures which, if not correctly followed, could result in personal injury, or loss of life.

CAUTION

This caution symbol identifies special instructions or procedures which, if not strictly observed, could result in damage to or destruction of equipment.

NOTE

- *This note symbol indicates points of particular interest for more efficient and convenient operation.*

FOREWORD

Congratulations on your purchase of a new Kawasaki motorcycle. Your new motorcycle is the product of Kawasaki's advanced engineering, exhaustive testing, and continuous striving for superior reliability, safety and performance.

Please read this Owner's Manual carefully before riding so that you will be thoroughly familiar with the proper operation of your motorcycle's controls, its features, capabilities, and limitations. This manual offers many safe riding tips, but its purpose is not to provide instruction in all the techniques and skills required to ride a motorcycle safely. Kawasaki strongly recommends that all operators of this vehicle enroll in a motorcycle rider training program to attain awareness of the mental and physical requirements necessary for safe motorcycle operation.

To ensure a long, trouble-free life for your motorcycle, give it the proper care and maintenance described in this manual. For those who would like more detailed information on their Kawasaki Motorcycle, a Service Manual is available for purchase from any authorized Kawasaki motorcycle dealer. The Service Manual contains detailed disassembly and maintenance information. Those who plan to do their own work should, of course, be competent mechanics and possess the special tools described in the Service Manual.

Keep this Owner's Manual aboard your motorcycle at all times so that you can refer to it whenever you need information.

This manual should be considered a permanent part of the motorcycle and should remain with the motorcycle when it is sold.

All rights reserved. No part of this publication may be reproduced without our prior written permission.

This publication includes the latest information available at the time of printing. However, there may be minor differences between the actual product and illustrations and text in this manual.

All products are subject to change without prior notice or obligation.

KAWASAKI HEAVY INDUSTRIES, LTD.
Consumer Products & Machinery Company

TABLE OF CONTENTS

SPECIFICATIONS	8	Fuel Tank Cap.....	32
SERIAL NUMBER LOCATIONS	12	Fuel Tank.....	33
LOCATION OF PARTS	13	Fuel Requirement:.....	34
LOCATION OF LABELS	16	Fuel Tap.....	37
LOADING INFORMATION	19	Stand.....	38
GENERAL INFORMATION	22	Helmet Hook.....	39
Meter Instruments.....	22	Tool Kit Case/Tool Kit.....	40
Speedometer, Odometer/Clock, and Trip Meter:.....	23	Side Cover.....	41
Speedometer :.....	23	Seat.....	43
Indicator Lights:.....	26	BREAK-IN	44
Key.....	27	HOW TO RIDE THE MOTORCYCLE .	46
Ignition Switch/Steering Lock.....	28	Starting the Engine.....	46
Right Handlebar Switches.....	29	Jump Starting.....	50
Engine Stop Switch:.....	29	Moving Off.....	52
Starter Button:.....	30	Shifting Gears.....	53
Left Handlebar Switches.....	31	Braking.....	55
Dimmer Switch:.....	31	Stopping the Engine.....	56
Turn Signal Switch:.....	31	Stopping the Motorcycle in an Emergency.....	57
Horn Button:.....	31	Parking.....	58

SAFE OPERATION	59	Brake Light Switches.....	108
Safe Riding Technique	59	Rear Shock Absorber.....	110
Daily Safety Checks	61	Wheels	112
Additional Considerations for Off		Battery.....	115
Road Operation	63	Headlight Beam.....	117
MAINTENANCE AND ADJUSTMENT	64	Fuses	119
Periodic Maintenance Chart.....	69	General Lubrication.....	121
Engine Oil	80	Cleaning Your Motorcycle	122
Spark Plugs.....	85	Bolt and Nut Tightening.....	127
Valve Clearance	87	STORAGE	129
Air Cleaner	87	TROUBLESHOOTING GUIDE	133
Throttle Grip	91	OWNER SATISFACTION	134
Carburetors	94	REPORTING SAFETY DEFECTS	136
Clutch	95	ENVIRONMENTAL PROTECTION	137
Drive Chain	98	MAINTENANCE RECORD	138
Brakes	103	LABEL INFORMATION	143

8 SPECIFICATIONS

SPECIFICATIONS

DIMENSIONS

Overall Length	2 080 mm (81.89 in.)
Overall Width	780 mm (30.71 in.)
Overall Height	1 190 mm (46.85 in.)
Wheelbase	1 375 mm (54.13 in.)
Road Clearance	270 mm (10.63 in.)
Curb Mass	128 kg (282 lb)

ENGINE

Type	DOHC, single-cylinder, 4-stroke, air-cooled
Displacement	249 cm ³ (15.2 cu in.)
Bore x Stroke	72.0 × 61.2 mm (2.83 × 2.41 in.)
Compression Ratio	9.3 : 1
Starting System	Electric starter
Carburetors	MIKUNI BST34
Ignition System	CDI

Ignition Timing (Electronically advanced)	10° BTDC @1 300 r/min (rpm) ~ 30° BTDC @5 750 r/min (rpm)
Spark Plugs	NGK CR8E or ND U24ESR-N
Lubrication System	Forced lubrication (wet sump)
Engine Oil	
Type:	API SE, SF or SG API SH, SJ, SL or SM with JASO MA, MA1 or MA2 SAE 10W-40
Capacity:	1.5 L (1.6 US qt)

TRANSMISSION

Transmission Type	6-speed, return shift
Clutch Type	Wet, multi disc
Driving System	Chain drive
Primary Reduction Ratio	2.800 (84/30)
Final Reduction Ratio	3.071 (43/14)
Overall Drive Ratio	7.326 (Top gear)

10 SPECIFICATIONS

Gear Ratio

1st	3.090 (34/11)
2nd	2.125 (34/16)
3rd	1.500 (27/18)
4th	1.148 (31/27)
5th	0.962 (25/26)
6th	0.852 (23/27)

FRAME

Castor	28°
Trail	107 mm (4.21 in.)
Tire Size:	
Front	2.75-21 45P
Rear	4.10-18 59P
Rim Size:	
Front	21 × 1.60
Rear	18 × 2.15
Fuel Tank Capacity	9.0 L (2.38 US gal)

ELECTRICAL EQUIPMENT

Battery	12 V 6 Ah
Headlight	12 V 60/55 W
Tail/Brake Light	12 V 5/21 W

Specifications subject to change without notice.

SERIAL NUMBER LOCATIONS

The engine and frame serial numbers are used to register the motorcycle. They are the only means of identifying your particular machine from others of the same model type. These serial numbers may be needed by your dealer when ordering parts. In the event of theft, the investigating authorities will require both numbers as well as the model type and any peculiar features of your machine that can help them identify it.

Frame No.

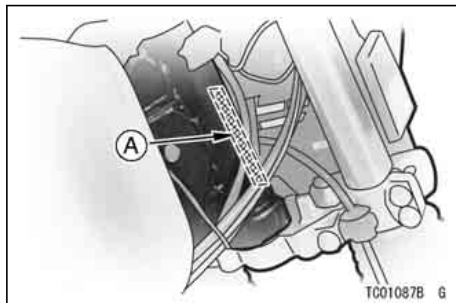

A. Frame Number

Engine No.

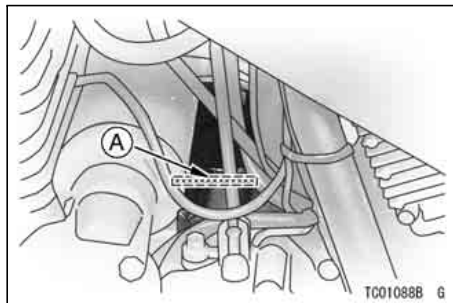

A. Engine Number

LOCATION OF PARTS

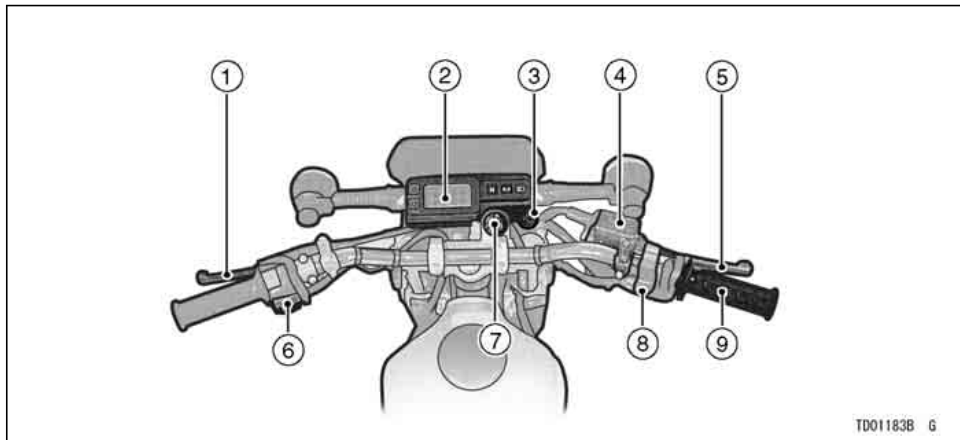

1. Clutch Lever
2. Meter Instruments
3. Choke Knob
4. Brake Fluid Reservoir (Front)
5. Front Brake Lever

6. Left Handlebar Switches
7. Ignition Switch/Steering Lock
8. Right Handlebar Switches
9. Throttle Grip

14 LOCATION OF PARTS

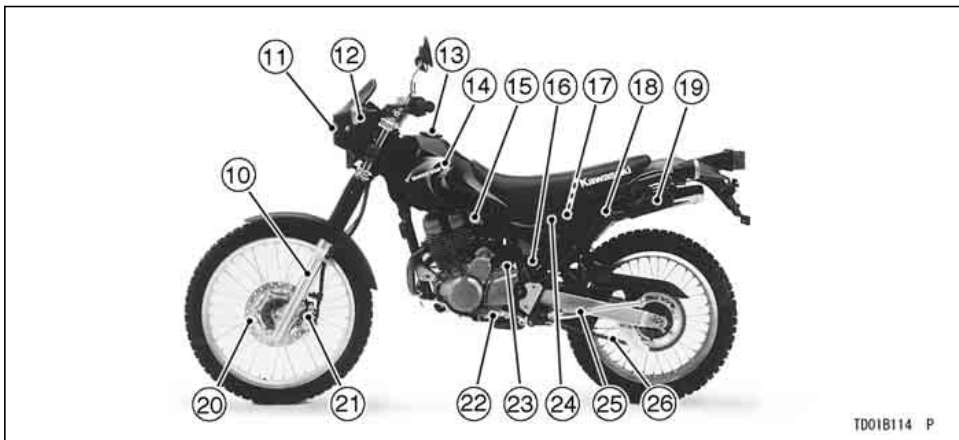

TD01B114 P

- 10. Front Fork
- 11. Headlight
- 12. Turn Signal Light
- 13. Fuel Tank Cap
- 14. Fuel Tank
- 15. Fuel Tap

- 16. Rear Shock Absorber
- 17. Battery
- 18. Helmet Hook
- 19. Tool Kit Case/Tool Kit
- 20. Brake Disc
- 21. Brake Caliper

- 22. Shift Pedal
- 23. Idle Adjusting Screw
- 24. Side Cover
- 25. Side Stand
- 26. Drive Chain

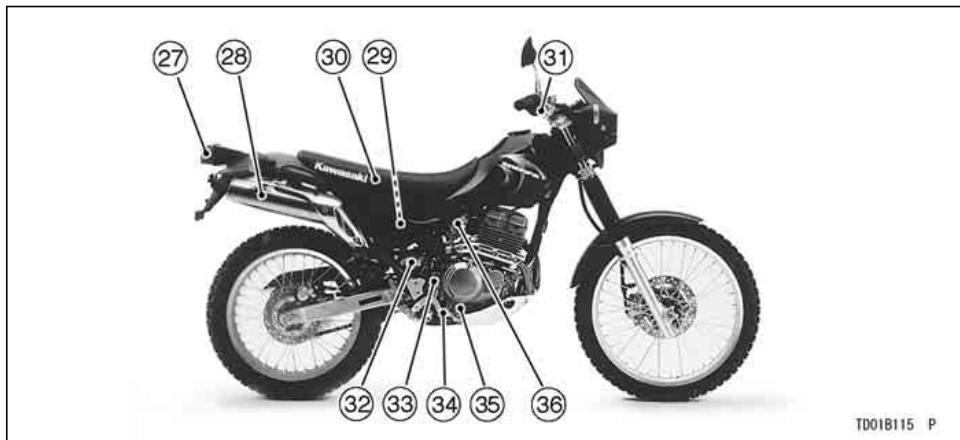

TD01B115 P

- 27. Tail/Brake Light
- 28. Muffler
- 29. Air Cleaner Element
- 30. Seat
- 31. Front Brake Light Switch

- 32. Brake Fluid Reservoir (Rear)
- 33. Rear Brake Light Switch
- 34. Rear Brake Pedal
- 35. Oil Level Gauge

- 36. Carburetor

LOCATION OF LABELS

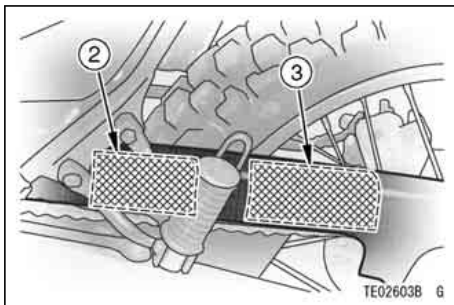
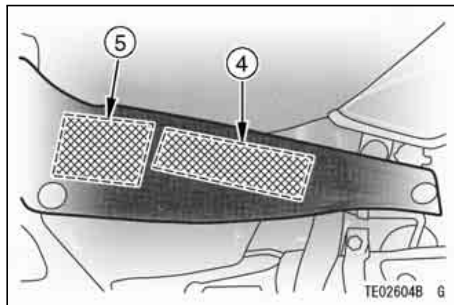
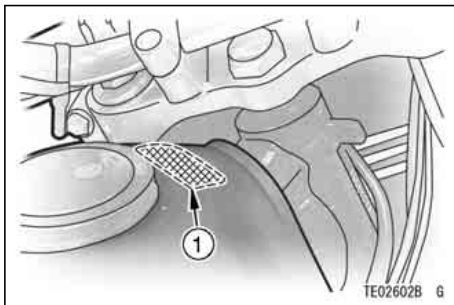

1. Important Break-In Instructions
2. Tire and Load Data
3. Important Drive Chain Information
4. Vehicle Emission Control Information
5. Daily Safety Checks

(For further information of label, refer to the "LABEL INFORMATION" chapter.)

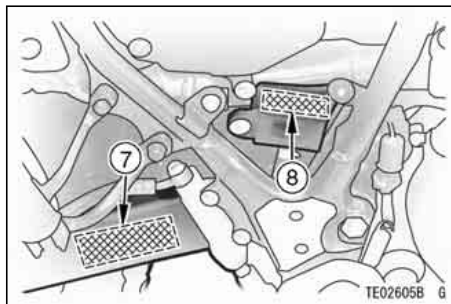
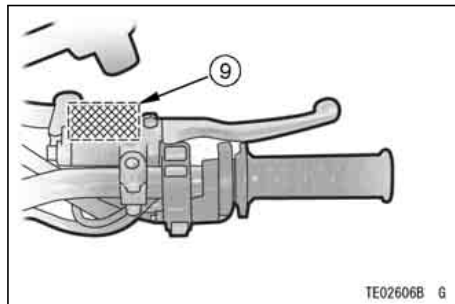
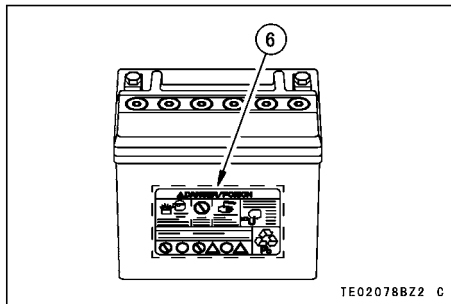

- 6. Battery Poison/Danger
- 7. Engine Oil and Oil Filter
- 8. Brake Fluid (Rear)
- 9. Brake Fluid (Front)

(For further information of label, refer to the "LABEL INFORMATION" chapter.)

18 LOCATION OF LABELS

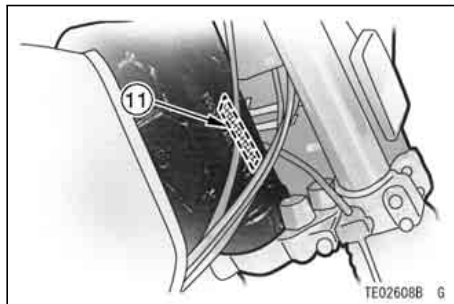
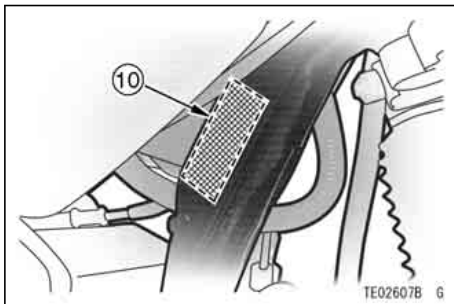

- 10. Noise Emission Control Information
- 11. Weight and Manufacture

(For further information of label, refer to the “LABEL INFORMATION” chapter.)

LOADING INFORMATION

 **WARNING**

Incorrect loading, improper installation or use of accessories, or modification of your motorcycle may result in an unsafe riding condition. Before you ride the motorcycle, make sure that the motorcycle is not overloaded and that you have followed these instructions.

With the exception of genuine Kawasaki Parts and Accessories, Kawasaki has no control over the design or application of accessories. In some cases, improper installation or use of accessories, or motorcycle modification, will void the motorcycle

warranty. In selecting and using accessories, and in loading the motorcycle, you are personally responsible for your own safety and the safety of other persons involved.

NOTE

○ *Kawasaki Parts and Accessories have been specially designed for use on Kawasaki motorcycles. We strongly recommend that all parts and accessories you add to your motorcycle be genuine Kawasaki components.*

Because a motorcycle is sensitive to changes in weight and aerodynamic forces, you must take extreme care in carrying cargo, passengers and/or in the fitting of additional accessories.

20 LOADING INFORMATION

The following general guidelines have been prepared to assist you in making your determinations.

1. Any passenger should be thoroughly familiar with motorcycle operation. The passenger can affect control of the motorcycle by improper positioning during cornering and sudden movements. It is important that the passenger sit still while the motorcycle is in motion and not interfere with the operation of the motorcycle. Do not carry animals on your motorcycle.
2. You should instruct any passenger before riding to keep his feet on the passenger footpegs and hold on to the operator grab rail. Do not carry a passenger unless he or she is tall enough to reach the footpegs and footpegs are provided.
3. All baggage should be carried as low as possible to reduce the effect on the motorcycle center of gravity. Baggage weight should also be distributed equally on both sides of the motorcycle. Avoid carrying baggage that extends beyond the rear of the motorcycle.
4. Baggage should be securely attached. Make sure that the baggage will not move around while you are riding. Recheck baggage security as often as possible (not while the motorcycle is in motion) and adjust as necessary.
5. Do not carry heavy or bulky items on a luggage rack. They are designed for light items, and overloading can affect handling due to changes in weight distribution and aerodynamic forces.

6. Do not install accessories or carry baggage that impairs the performance of the motorcycle. Make sure that you have not adversely affected any lighting components, road clearance, banking capability (i.e., lean angle), control operation, wheel travel, front fork movement, or any other aspect of the motorcycle's operation.
7. Weight attached to the handlebar or front fork will increase the mass of the steering assembly and can result in an unsafe riding condition.
8. Fairings, windshields, backrests, and other large items have the capability of adversely affecting stability and handling of the motorcycle, not only because of their weight, but also due to the aerodynamic forces acting on these surfaces while the motorcycle is in operation. Poorly designed or installed items can result in an unsafe riding condition.
9. This motorcycle was not intended to be equipped with a sidecar or to be used to tow any trailer or other vehicle. Kawasaki does not manufacture sidecars or trailers for motorcycles and cannot predict the effects of such accessories on handling or stability, but can only warn that the effects can be adverse and that Kawasaki cannot assume responsibility for the results of such unintended use of the motorcycle. Furthermore, any adverse effects on motorcycle components caused by the use of such accessories will not be remedied under warranty.

Maximum Load

Weight of rider, passenger, baggage, and accessories must not exceed 165 kg (364 lb).

Meter Instruments

- A. Speedometer
- B. Odometer/Clock
- C. Twin Trip Meter
- D. Odometer/Clock Mode Button
- E. Trip A/B Mode Button
- F. Neutral Indicator Light
- G. Turn Signal Indicator Light
- H. High Beam Indicator Light

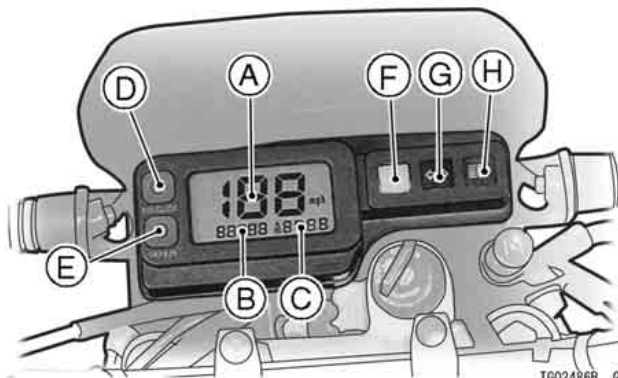

Speedometer, Odometer/Clock, and Trip Meter:

In the meter instruments face are the LCD (Liquid Crystal Display) speedometer, odometer/clock and trip meter. Pushing the odometer/clock (ODO/CLOCK) mode button shifts the display in the odometer/clock through the two modes; odometer and clock. Pushing the trip meter A/B (TRIP A/B) mode button shifts the display in the trip meter through the two modes; trip A and B. When the ignition switch is turned on, all the LCD segments are displayed for three seconds, then the clock or meters operate normally depending on the mode selected.

Speedometer :

The speedometer shows the speed of the vehicle.

Odometer -

The odometer shows the total distance in kilometers that the vehicle has been ridden. The meter cannot be reset.

NOTE

- *The data is maintained even if the battery is disconnected.*
- *When the figures come to 99999, they are stopped and locked.*

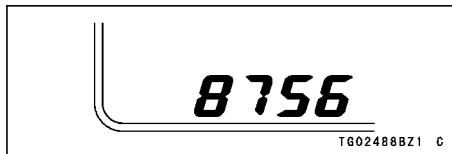

Clock:

To adjust hours and minutes:

- Turn the ignition key to "ON".
- Push the ODO/CLOCK button, and display the clock.

24 GENERAL INFORMATION

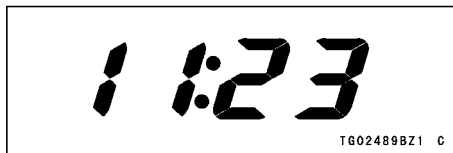

- Push the TRIP A/B button with the ODO/CLOCK button pushed in. Both the hour and minute displays start flashing.

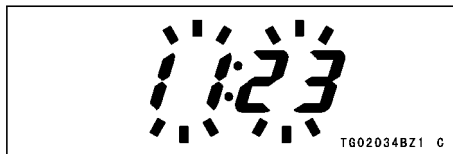

- Again push the ODO/CLOCK button, then the hour display only flashes. And push the TRIP A/B button to advance the hours.



- Push the ODO/CLOCK button. The hour display stops flashing and the minute display starts flashing. And push the TRIP A/B button to advance the minutes.

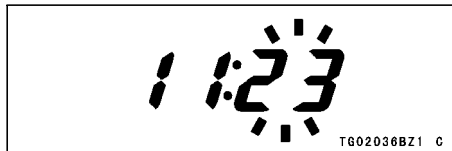

- Push the ODO/CLOCK button. Both the hour and minute displays start flashing again.
- Push the TRIP A/B button. The display stop flashing and the clock starts working.

NOTE

- *Pushing the TRIP A/B button momentarily advances the hour or minute step by step. Pushing and holding the button advance the hour or minute continuously.*
- *The clock works normally from the back-up power while the ignition switch is turned off.*
- *When the battery is disconnected, the clock resets to 1:00 and starts working again when the battery is connected.*

Trip Meters A/B -

The trip meter shows the distance in kilometers traveled since it was last reset to zero.

TRIP A: 0.0 ~ 999.9

TRIP B: 0 ~ 9999

To reset the trip meter:

- Push the TRIP A/B button and hold it in.
- After two second, the figure display turns to 0.0 (TRIP A) or 0 (TRIP B), and then starts counting when the vehicle is operated. The meter counts until it is next reset.

NOTE

- *The data is maintained by the back-up power if the ignition key is turned to "OFF"*
- *When the trip meter is reset while the vehicle is stopped, it starts counting as soon as the vehicle starts moving.*
- *When the figures come to 999.9 (TRIP A) or 9999 (TRIP B) when the vehicle is running, they turn back to 0.0 and start counting again.*
- *When the battery is disconnected, the meter display resets to 0.0 or 0.*

26 GENERAL INFORMATION

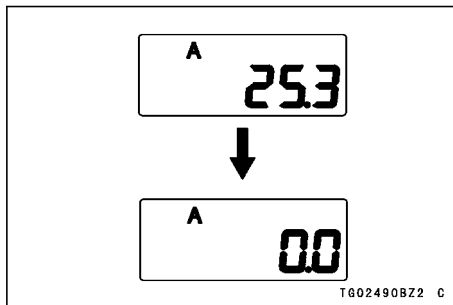

Indicator Lights:

N : When the transmission is in neutral, the neutral indicator light is lit.

↔ : When the turn signal switch is turned to left or right, the turn signal indicator light flashes on and off.

☰☷ : When the headlight is on high beam, the high beam indicator light is lit.

Key

This motorcycle has a combination key, which is used for the ignition switch/steering lock, helmet hook, and fuel tank cap.

Blank keys are available at your Kawasaki dealers. Ask your dealer to make any additional spare keys you may need, using your original key as a master, or using the key code on the tag with your keys.

Record the code on the tag with your keys here. Participating Kawasaki dealers can use the code to make a new key in the event that your original keys are lost.

Write your key number here.

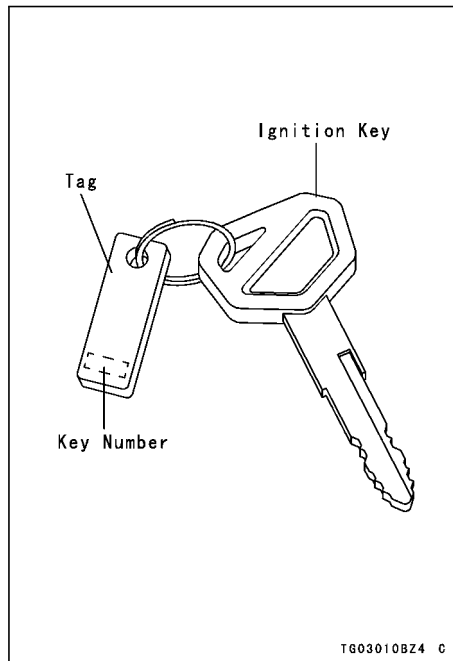

Ignition Switch/Steering Lock

This is a four-position, key-operated switch. The key can be removed from the switch when it is in the OFF, LOCK, or P (Park) position.

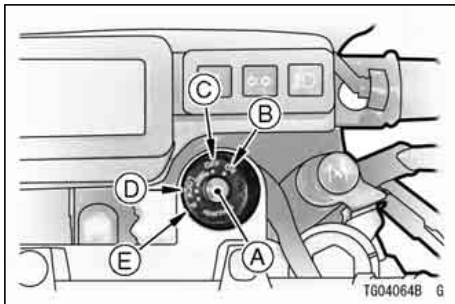

- A. Ignition Switch/Steering Lock
- B. ON position
- C. OFF position
- D. LOCK position
- E. P (Park) position

ON	Engine on. All electrical equipment can be used.
OFF	Engine off. All electrical circuits off.
LOCK	Steering locked. Engine off. All electrical circuits off.
P (Park)	Steering locked. Engine off. Taillight on. All other electrical circuits cut off.

NOTE

- *The headlight and taillight are on whenever the ignition key is in the ON position. To avoid battery discharge, always start the engine immediately after turning the ignition key to "ON".*
- *If you leave the P (Park) position on for a long time (one hour), the battery may become totally discharged.*

To lock the steering:

1. Turn the handlebar fully to the left.
2. With the ignition key in the OFF position, push down and release the key.
3. Turn the key to LOCK or P (Park) position.
4. Pull the key out.

NOTE

- *If the steering is hard to lock, turn the handlebar slightly to the left or the right.*

Right Handlebar Switches**Engine Stop Switch:**

In addition to the ignition switch, the engine stop switch must be in the **RUN** position (RUN switch pushed in) for the motorcycle to operate.

The engine stop switch is for emergency use. If some emergency requires stopping the engine, push the engine stop switch to the **OFF** position (OFF switch pushed in).

NOTE

- *Although the engine stop switch stops the engine, it does not turn off all the electrical circuits. Ordinarily, the ignition switch should be used to stop the engine.*

30 GENERAL INFORMATION

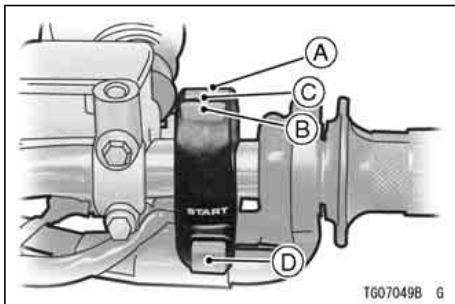

Refer to the Starting the Engine section of the "How to Ride the Motorcycle" chapter for starting instructions.

- A. Engine Stop Switch
- B. RUN Switch
- C. OFF Switch
- D. Starter Button

Starter Button:

The starter button operates the electric starter when pushed with the clutch lever pulled in or the transmission is in neutral.

Left Handlebar Switches

Dimmer Switch:

High or low beam can be selected with the dimmer switch. When the headlight is on high beam (HI), the high beam indicator light is lit.

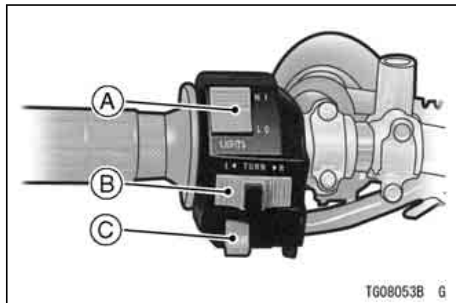

- A. Dimmer Switch
- B. Turn Signal Switch
- C. Horn Button

Turn Signal Switch:

When the turn signal switch is turned to L (left) or R (right), the corresponding turn signals flash on and off.

To stop flashing, push the switch in.

Horn Button:

When the horn button is pushed, the horn sounds.

32 GENERAL INFORMATION

Fuel Tank Cap

To open the fuel tank cap, insert the ignition key into the fuel tank cap, turn the key to the right.

To close the cap, push it down into place with the key inserted. The key can be removed by turning it to the left to the original position.

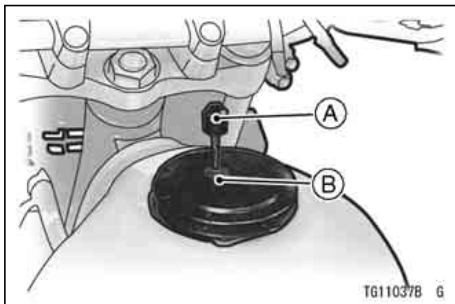

A. Ignition Key

B. Fuel Tank Cap

NOTE

- *The fuel tank cap cannot be closed without the key inserted, and the key cannot be removed unless the cap is locked properly.*
- *Do not push on the key to close the cap, or the cap cannot be locked.*

Fuel Tank

The following octane rating gasoline is recommended in the fuel tank. Avoid filling the tank in the rain or where heavy dust is blowing so that the fuel does not get contaminated.

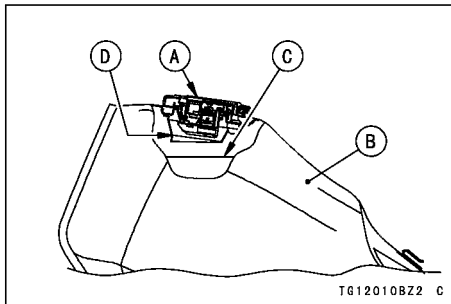

- A. Tank Cap
- B. Fuel Tank
- C. Top Level
- D. Filler Neck

! WARNING

Gasoline is extremely flammable and can be explosive under certain conditions. Turn the ignition key to "OFF". Do not smoke. Make sure the area is well ventilated and free from any source of flame or sparks; this includes any appliance with a pilot light. Never fill the tank so the fuel level rises into the filler neck. If the tank is overfilled, heat may cause the fuel to expand and overflow through the vents in the tank cap. After refueling, make sure the fuel tank cap is closed securely. If gasoline is spilled on the fuel tank, wipe it off immediately.

34 GENERAL INFORMATION

Fuel Requirement:

Fuel Type

Use clean, fresh unleaded gasoline with a minimum Antiknock Index of 87. The Antiknock Index is posted on service station pumps. The octane rating of a gasoline is a measure of its resistance to detonation or "knocking." The Antiknock Index is an average of the Research Octane Number (RON) and the Motor Octane Number (MON) as shown in the table.

Octane Rating Method	Minimum Rating
Antiknock Index $\frac{(\text{RON} + \text{MON})}{2}$	87

CAUTION

If engine "knocking" or "pinging" occurs, use a different brand of gasoline of a higher octane rating. If this condition is allowed to continue it can lead to severe engine damage.

Gasoline quality is important. Fuels of low quality or not meeting standard industry specifications may result in unsatisfactory performance. Operating problems that result from the use of poor quality or nonrecommended fuel may not be covered under your warranty.

Fuels Containing Oxygenates

Gasoline frequently contains oxygenates (alcohols and ethers) especially in areas of the U.S. and Canada

which are required to sell such reformulated fuels as part of a strategy to reduce exhaust emissions.

The types and volume of fuel oxygenates approved for use in unleaded gasoline by the U.S. Environmental Protection Agency include a broad range of alcohols and ethers, but only two components have seen any significant level of commercial use.

Gasoline/Alcohol Blends - Gasoline containing up to 10% ethanol (alcohol produced from agricultural products such as corn), also known as "gasohol" is approved for use.

CAUTION

Avoid using blends of unleaded gasoline and methanol (wood alcohol) whenever possible, and never use "gasohol" containing more than 5% methanol. Fuel system damage and performance problems may result.

Gasoline/Ether Blends - The most common ether is methyl tertiary butyl ether (MTBE). You may use gasoline containing up to 15% MTBE.

NOTE

- *Other oxygenates approved for use in unleaded gasoline include TAME (up to 16.7 %) and ETBE (up to 17.2 %). Fuel containing these oxygenates can also be used in your Kawasaki.*

CAUTION

Never use gasoline with an octane rating lower than the minimum specified by Kawasaki.

Never use "gasohol" with more than 10% ethanol, or more than 5% methanol. Gasoline containing methanol must also be blended with cosolvents and corrosion inhibitors.

Certain ingredients of gasoline may cause paint fading or damage. Be extra careful not to spill gasoline or gasoline oxygenate blends during refueling.

When not operating your Kawasaki for 30 to 60 days, mix a fuel stabilizer (such as STA-BIL) with the gasoline in the fuel tank. Fuel stabilizer additives inhibit oxidation of the fuel which minimizes gummy deposits.

CAUTION

Never store this product with "gasohol" in the fuel system. Before storage it is recommended that you drain all fuel from the fuel tank and carburetor. See the Storage section in this manual.

Fuel Tap

The fuel tap is an automatic type which shuts off the fuel supply when the engine is stopped in the ON or RES position.

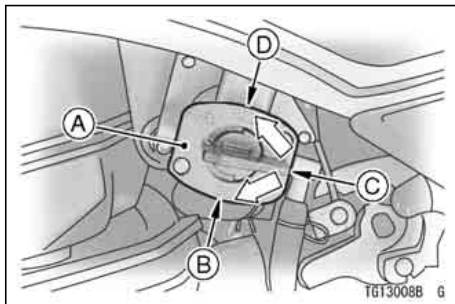

- A. Fuel Tap
- B. ON position
- C. PRI position
- D. RES position

The fuel tap has three positions: ON, RES (reserve), and PRI (prime). For normal operation, turn the tap lever to

the ON position. If the fuel runs out with the tap in the ON position, turn the tap lever to PRI, leave it for a few seconds, and then turn it to RES. The last 3.0 L (0.80 US gal) of fuel can be used by turning the fuel tap lever to RES.

The PRI position bypasses the automatic control and is useful for priming the engine after running out of gas, or for completely draining the fuel tank.

NOTE

- *Since riding distance is limited when on RES, refuel at the earliest opportunity.*
- *Make certain that the fuel tap lever is turned to ON (Not RES) after filling up the fuel tank.*
- *To start a cold engine after the motorcycle has been stored for a long time, first turn the tap lever to PRI, leave it for a moment, and return it to "ON".*

! WARNING

Practice operating the fuel tap with the motorcycle stopped. To prevent an accident you should be able to operate the fuel tap while riding without taking your eyes off the road.

Be careful not to touch the hot engine while operating the fuel tap.

Do not leave the fuel tap in the PRI (prime) position while riding or parking the motorcycle. The engine may become flooded or fuel may spill onto the ground and create a fire hazard, if the vehicle falls over.

Stand

The motorcycle is equipped with a side stand.

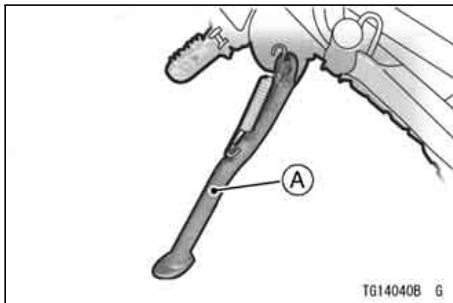

A. Side Stand

NOTE

○ *When using the side stand, turn the handlebar to the left.*

Whenever the side stand is used, make it a practice to kick the stand fully up before sitting on the motorcycle.

NOTE

- *The motorcycle is equipped with a side stand switch. This switch is designed so that the engine dose not start if the transmission is in gear and the side stand is left down.*

Helmet Hook

Helmet can be secured to the motorcycle using the helmet hook located at the front of the tool kit case.

The helmet hook can be unlocked by inserting the ignition key into the lock, and turning the key to the right.

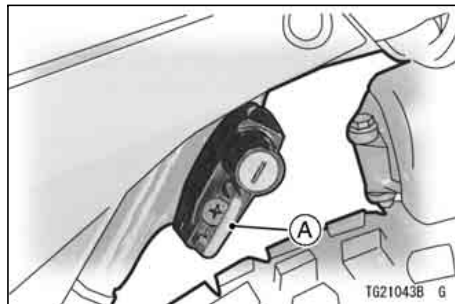

A. Helmet Hook

! WARNING

Do not ride the motorcycle with a helmet attached to the hook. The helmet could cause an accident by distracting the operator or interfering with normal vehicle operation.

Tool Kit Case/Tool Kit

The tool kit is stored in the tool kit case.

The kit contains tools that can be helpful in making roadside repairs, adjustments, and some maintenance procedures explained in this manual.

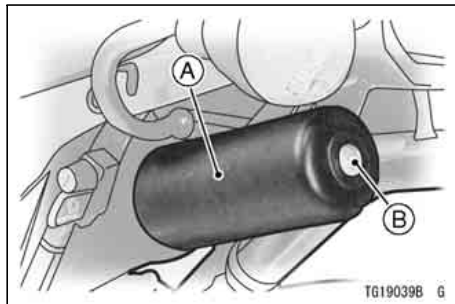

- A. Tool Kit Case**
- B. Screw**

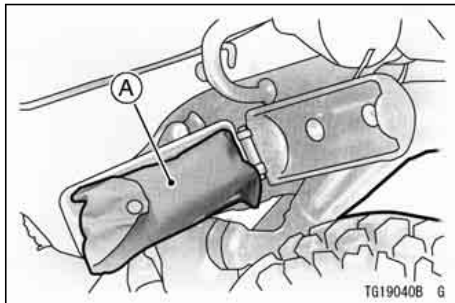

A. Tool Kit

Side Cover

The left and right side covers are removed for battery removal or installation and air cleaner element cleaning.

Right and Left Side Cover Removal

- To remove the right and left side cover, remove a screw of the left side cover (two screws of the right side cover), and pull out the left and right side cover.

42 GENERAL INFORMATION

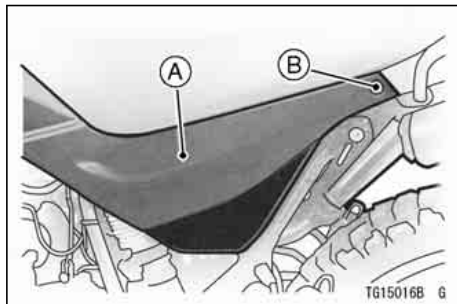

A. Left Side Cover
B. Screw

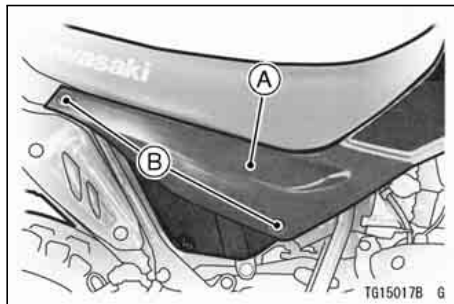

A. Right Side Cover
B. Screws

Seat

Seat Removal

To remove the seat, follow this step.

1. Remove the left and right side covers.
2. Remove the seat mounting bolts.
3. Pull the seat up and to the rear.

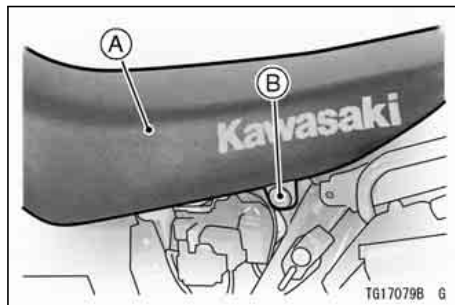

A. Seat

B. Mounting Bolt

BREAK-IN

The first 1 600 km (1 000 mi) that the motorcycle is ridden is designated as the break-in period. If the motorcycle is not used carefully during this period, you may very well end up with a "broken down" instead of a "broken in" motorcycle after a few thousand kilometers.

The following rules should be observed during the break-in period.

- The table shows maximum recommended engine speed during the break-in period.

Gear Position	1st	2nd	3rd	4th	5th	6th
Distance traveled						
0 ~ 800 km (0 ~ 500 mi)	20 (12)	30 (18)	40 (25)	50 (31)	60 (38)	70 (44)
800 ~ 1,600 km (500 ~ 1,000 mi)	30 (18)	40 (25)	50 (31)	60 (38)	70 (44)	85 (53)

NOTE

- *When operating on public roadways, keep maximum speed under traffic law limits.*

- Do not start moving or race the engine immediately after starting it, even if the engine is already warm. Run the engine for two or three minutes at idle speed to give the oil a chance to work up into all the engine parts.
- Do not race the engine while the transmission is in neutral.

 **WARNING**

New tires are slippery and may cause loss of control and injury. A break-in period of 160 km (100 miles) is necessary to establish normal tire traction. During break-in, avoid sudden and maximum braking and acceleration, and hard cornering.

In addition to the above, at 1 000 km (600 mi) it is extremely important that the owner have the initial maintenance service performed by a compartment mechanic following the procedures in the Service Manual.

HOW TO RIDE THE MOTORCYCLE

Starting the Engine

- Turn the fuel tap lever to "ON" position.

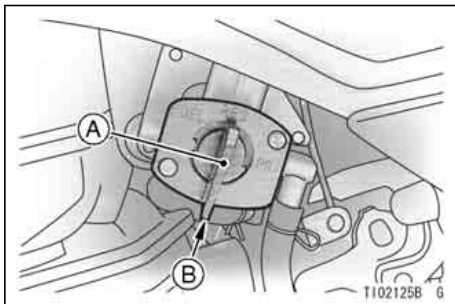

- A. Fuel Tap Lever
B. ON position

NOTE

- *To start a cold engine after the motorcycle has been stored for a long time,*

first turn the tap lever to PRI, leave it for a moment, and return it to ON.

- Check that the engine stop switch is in the RUN position (RUN switch pushed in).

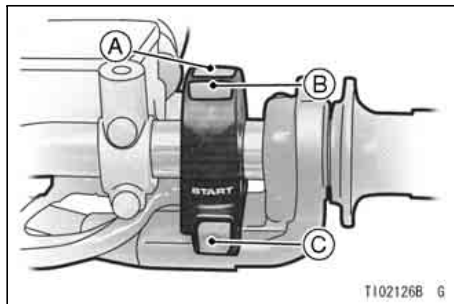

- A. Engine Stop Switch
B. RUN Switch
C. Starter Button

- Turn the ignition key to "ON".
- Make certain the transmission is in neutral.

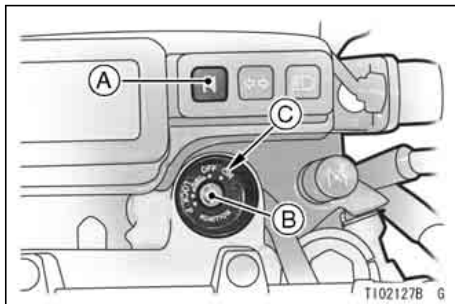

- A. Neutral Indicator Light
- B. Ignition Switch
- C. ON position

- If the engine is cold, pull up the choke knob all the way.

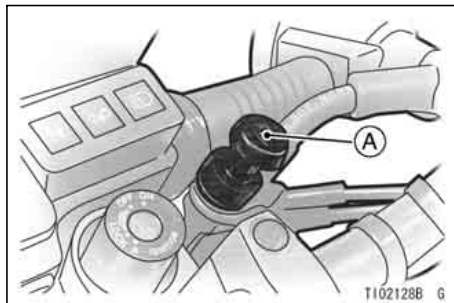

A. Choke Knob

NOTE

- *When the engine is already warm or on hot days (35°C, 95°F or more), close the throttle completely without using the choke knob, and then start the engine.*

48 HOW TO RIDE THE MOTORCYCLE

- Leaving the throttle completely closed, push the starter button.

CAUTION

Do not operate the starter continuously for more than 5 seconds or the starter will overheat and the battery power will drop temporarily. Wait 15 seconds between each operation of the starter to let it cool and the battery power recover.

NOTE

- If the engine is flooded, crank the engine over with the throttle fully open until the engine starts.
- The motorcycle is equipped with a starter lockout switch. This switch

prevents the electric starter from operating when the clutch is engaged and the transmission is not in neutral.

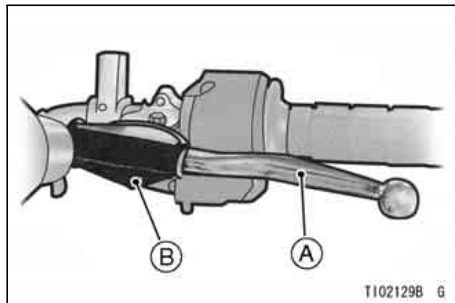

- A. Clutch Lever
- B. Starter Lockout Switch

- Gradually push the choke knob back a little at a time as necessary to keep the engine running properly during warm-up.
- When the engine is warmed up enough to idle without using the

choke, and push the choke knob all the way back.

NOTE

- *If you drive the motorcycle before the engine is warmed up, return the choke knob all the way after you have driven the motorcycle for the length of time shown in the table.*

CAUTION

Do not let the engine idle longer than five minutes, or engine overheating and damage may occur.

Ambient temperature	Choke off after running for
20°C (68°F) ~ 35°C (95°F)	15 seconds
Below 20°C (68°F)	1.5 minutes
Below 5°C (40°F)	2 minutes

Jump Starting

If your motorcycle battery is "run down", it should be removed and charged. If this is not practical, a 12 volt booster battery and jumper cables may be used to start the engine.

WARNING

Battery acid generates hydrogen gas which is flammable and explosive under certain conditions. It is present within a battery at all times, even in a discharged condition. Keep all flames and sparks (cigarettes) away from the battery. Wear eye protection when working with a battery. In the event of battery acid contact with skin, eyes, or clothing, wash the affected areas immediately with water for at least five minutes. Seek medical attention.

Connecting Jumper Cables

- Remove the left side cover.
- Make sure the ignition key is turned "OFF".

- Connect a jumper cable from the positive (+) terminal of the booster battery to the positive (+) battery terminal at the starter relay.

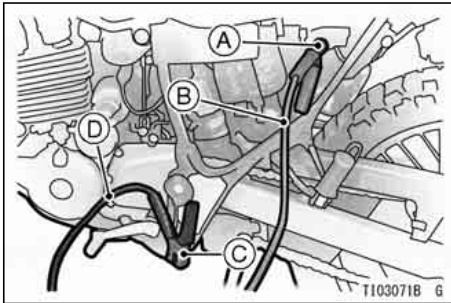

- A. Battery-connected Starter Relay Terminal
 B. From Booster Battery Positive (+) Terminal
 C. Unpainted Metal Surface
 D. From Booster Battery Negative (-) Terminal

- Connect another jumper cable from the negative (-) terminal of the booster battery to your motorcycle

shift pedal or other unpainted metal surface. Do not use the negative (-) terminal of the battery.

! WARNING

Do not make this last connection at the carburetor or battery. Take care that you do not touch the positive and negative cables together, and do not lean over the battery when making this last connection. Do not jump start a frozen battery. It could explode. Do not reverse polarity by connecting positive (+) to negative (-), or a battery explosion and serious damage to the electrical system may occur.

- Follow the standard engine starting procedure.

CAUTION

Do not operate the starter continuously for more than 5 seconds or the starter will overheat and the battery power will drop temporarily. Wait 15 seconds between each operation of the starter to let it cool and the battery power recover.

- After the engine has started, disconnect the jumper cables. Disconnect the negative (-) cable from the motorcycle first.
- Reinstall the parts removed.

Moving Off

- Check that the side stand is up.
- Pull in the clutch lever.
- Shift into 1st gear.
- Open the throttle a little, and start to let out the clutch lever very slowly.
- As the clutch starts to engage, open the throttle a little more, giving the engine just enough fuel to keep it from stalling.

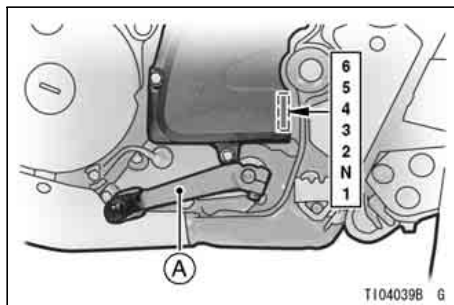
**A. Shift Pedal**

NOTE

- *The motorcycle is equipped with a side stand switch. This switch is designed so that the engine stops if the clutch is engaged with the transmission in gear when the side stand is left down.*

Shifting Gears

- Close the throttle while pulling in the clutch lever.
- Shift into the next higher or lower gear. For smooth riding, shift up or down when the motorcycle is operated the speeds shown in the table.
- Open the throttle part way, while releasing the clutch lever.

WARNING

When shifting down to a lower gear, do not shift at such a high speed that the engine r/min (rpm) jumps excessively. Not only can this cause engine damage, but the rear wheel may skid and cause an accident. Downshifting should be done the vehicle speeds shown in the table in this section.

54 HOW TO RIDE THE MOTORCYCLE

Vehicle speed when shifting

Shifting up	km/h (mph)	Shifting down	km/h (mph)
1st → 2nd	15 (9)	6th → 5th	30 (19)
2nd → 3rd	25 (15)	5th → 4th	25 (15)
3rd → 4th	35 (21)	4th → 3rd	20 (12)
4th → 5th	45 (27)	3rd → 2nd	15 (9)
5th → 6th	55 (34)	2nd → 1st	15 (9)

Braking

- Close the throttle completely, leaving the clutch engaged (except when shifting gears) so that the engine will help slow down the motorcycle.
- Shift down one gear at a time so that you are in 1st gear when you come to a complete stop.
- When stopping, always apply both brakes at the same time. Normally the front brake should be applied a little more than the rear. Shift down or fully disengage the clutch as necessary to keep the engine from stalling.
- Never lock the brakes, or it will cause the tires to skid. When turning a corner, it is better not to brake at all. Reduce your speed before you get into the corner.

- For emergency braking, disregard downshifting, and concentrate on applying the brakes as hard as possible without skidding.

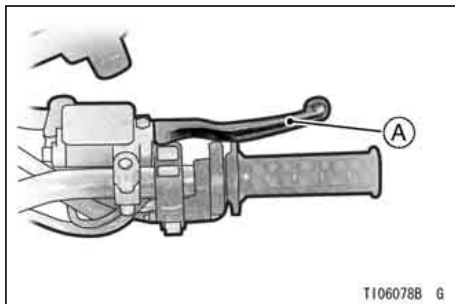

A. Front Brake Lever

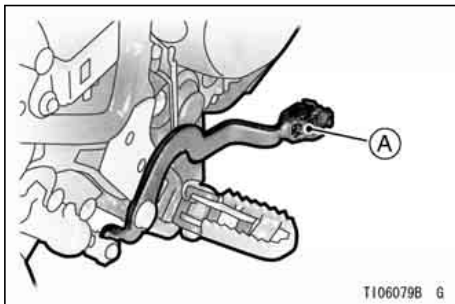

A. Rear Brake Pedal

Stopping the Engine

- Close the throttle completely.
- Shift the transmission into neutral.
- Turn the ignition key to "OFF".
- Support the motorcycle on a firm level surface with the side stand.
- Lock the steering.

Stopping the Motorcycle in an Emergency

Your Kawasaki Motorcycle has been designed and manufactured to provide you optimum safety and convenience. However, in order to fully benefit from Kawasaki's safety engineering and craftsmanship, it is essential that you, the owner and operator, properly maintain your motorcycle and become thoroughly familiar with its operation. Improper maintenance can create a dangerous situation known as throttle failure. Two of the most common causes of throttle failure are:

1. An improperly serviced or clogged air cleaner may allow dirt and dust to enter the carburetor and stick the throttle open.

2. During removal of the air cleaner, dirt is allowed to enter and jam the carburetor.

In an emergency situation such as throttle failure, your vehicle may be stopped by applying the brakes and disengaging the clutch. Once this stopping procedure is initiated, the engine stop switch may be used to stop the engine. If the engine stop switch is used, turn off the ignition switch after stopping the motorcycle.

Parking

- Shift the transmission into neutral and turn the ignition key to "OFF".
- Support the motorcycle on a firm, level surface with the side stand.

CAUTION

Do not park on a soft or steeply inclined surface, or the motorcycle may fall over.

- If parking inside a garage or other structure, be sure it is well ventilated and the motorcycle is not close to any source of flame or sparks; this includes any appliance with a pilot light.



WARNING

Gasoline is extremely flammable and can be explosive under certain conditions.

- Lock the steering to help prevent theft.

NOTE

- *When stopping near traffic at night, you can leave taillight on for greater visibility by turning the ignition key to the P (Park) position.*
- *Do not leave the ignition switch at P position too long, or the battery will discharge.*

SAFE OPERATION

Safe Riding Technique

The points given below are applicable for everyday motorcycle use and should be carefully observed for safe and effective vehicle operation.

For safety, eye protection and a helmet are strongly recommended. Gloves and suitable footwear should also be used for added protection in case of a mishap.

A motorcycle does not provide the impact protection of an automobile, so defensive riding in addition to wearing protective apparel is extremely important. Do not let protective apparel give you a false sense of security.

Before changing lanes, look over your shoulder to make sure the way is clear. Do not rely solely on the rear view mirror; you may misjudge a vehicle's distance and speed, or you may not see it at all.

When going up steep slopes, shift to a lower gear so that there is plenty of power to spare rather than overloading the engine.

When applying the brakes, use both the front and rear brakes. Applying only one brake for sudden

60 SAFE OPERATION

braking may cause the motorcycle to skid and lose control.

When going down long slopes, control vehicle speed by closing the throttle. Use the front and rear brakes for auxiliary braking.

In wet conditions, rely more on the throttle to control vehicle speed and less on the front and rear brakes. The throttle should also be used judiciously to avoid skidding the rear wheel from too rapid acceleration or deceleration.

Riding at the proper rate of speed and avoiding unnecessarily fast acceleration are important not only for safety and low fuel consumption but also for long vehicle life and quieter operation.

When riding in wet conditions or on loose roadway surfaces, the ability to maneuver will be reduced. All of your actions should be smooth under these conditions. Sudden acceleration, braking or turning may cause loss of control.

On rough roads, exercise caution, slow down, and grip the fuel tank with the knees for better stability.

When quick acceleration is necessary as in passing, shift to a lower gear to obtain the necessary power.

Do not downshift at too high an r/min (rpm) to avoid damage to the engine from overrevving.

Avoiding unnecessary weaving is important to the safety of both the rider and other motorists.

Daily Safety Checks

Check the following items each day before you ride. The time required is minimal, and habitual performance of these checks will help ensure you a safe, reliable ride.

If any irregularities are found during these checks, refer to the Maintenance and Adjustment chapter or see your dealer for the action required to return the motorcycle to a safe operating condition.

WARNING

Failure to perform these checks every day before you ride may result in serious damage or a severe accident.

- Fuel Adequate supply in tank, no leaks.
 Engine oil Oil level between level lines.
 Tires Air pressure (when cold):

Front	Up to 165 kg (364 lb) Load	150 kPa (1.50 kgf/cm ² , 21 psi)
Rear	Up to 97.5 kg (215 lb) Load	150 kPa (1.50 kgf/cm ² , 21 psi)
	97.5 ~ 165 kg (215 ~ 364 lb) Load	175 kPa (1.75 kgf/cm ² , 25 psi)

62 SAFE OPERATION

Drive chain	Slack 35 ~ 55 mm (1.4 ~ 2.2 in.). Lubricate if dry
Nuts, bolts, fasteners ..	Check that steering and suspension components, axles, and all controls are properly tightened or fastened.
Steering	Action smooth but not loose from lock to lock. No binding of control cables.
Brakes	Brake pad wear: Lining thickness more than 1 mm (0.04 in.) left. No brake fluid leakage. Brake lever play 2 ~ 5 mm (0.08 ~ 0.20 in.)
Throttle	Throttle grip play 2 ~ 3 mm (0.08 ~ 0.12 in.).
Clutch	Clutch lever play 2 ~ 3 mm (0.08 ~ 0.12 in.). Clutch lever operates smoothly.
Electrical equipment ...	All lights and horn work.
Engine stop switch	Stops engine.
Side stand	Return to its fully up position by spring tension. Return spring not weak or not damaged.

Refer to the "Daily Safety Checks" caution label attached to the back of the right side cover.

Additional Considerations for Off Road Operation

Brakes: The importance of reliable brakes is obvious. Check to see that they are correctly adjusted and functioning properly.

Steering: Looseness in the steering can cause loss of control. Check to see that the handlebar turns freely but has no play.

Tires: Due to the extra stress to the tires on rough roads, be sure to examine their overall condition, and inflate them to the proper pressure.

Drive Chain: When not adjusted properly, the severe stress on rough roads can cause damage to the sprockets and cause the chain to be thrown. Examine the chain slack and alignment, and lubricate if necessary.

Fuel: Have sufficient fuel for the high fuel consumption on rough roads.

Engine Oil: To avoid engine seizure and resulting loss of control, make certain the oil level is at the upper level line.

Miscellaneous: Check to see that the electrical equipment is functioning properly, all nuts and bolts are tight, and all safety related parts are in good condition.

MAINTENANCE AND ADJUSTMENT

The maintenance and adjustments outlined in this chapter are easily carried out and must be done in accordance with the Periodic Maintenance Chart to keep the motorcycle in good running condition. **The initial maintenance is vitally important and must not be neglected.**

If you are in doubt as to any adjustment or vehicle operation, please ask your authorized Kawasaki dealer to check the motorcycle.

Please note that Kawasaki cannot assume any responsibility for damage resulting from incorrect maintenance or improper adjustment done by the owner.

EMISSION CONTROL INFORMATION

To protect the environment in which we all live, Kawasaki has incorporated crankcase emission (1) and exhaust emission (2) control systems in compliance with applicable regulations of the United States Environmental Protection Agency.

1. Crankcase Emission Control System

This system eliminates the release of crankcase vapors into the atmosphere. Instead, the vapors are routed through an oil separator to the intake side of the engine. While the engine is operating, the vapors are drawn into the combustion chamber, where they are burned along with the fuel and air supplied by the carburetor.

2. Exhaust Emission Control System

This system reduces the amount of pollutants discharged into the atmosphere by the exhaust of this motorcycle. The fuel and ignition systems of this motorcycle have been carefully designed and constructed to ensure an efficient engine with low exhaust pollutant levels.

High Altitude Performance Adjustment Information

To improve the EMISSION CONTROL PERFORMANCE of vehicles operated above 4 000 feet, Kawasaki recommends the following Environmental Protection Agency (EPA) approved modification.

NOTE

- *When properly performed, these specified modifications only are not considered to be emissions system “tampering” and vehicle performance is generally unchanged as a result.*

Installation Instructions:

High altitude adjustment requires replacement of certain carburetor components. Installation of these optional parts may be performed by an authorized Kawasaki dealer, or the consumer, following repair recommendations specified in the appropriate Kawasaki Service Manual.

MAINTENANCE AND WARRANTY

Proper maintenance is necessary to ensure that your motorcycle will continue to have low emission levels. This Owner's Manual contains those maintenance recommendations for your motorcycle. Those items identified by the Periodic Maintenance Chart are necessary to ensure compliance with the applicable standards.

As the owner of this motorcycle, you have the responsibility to make sure that the recommended maintenance is carried out according to the instructions in this Owner's Manual at your own expense.

The Kawasaki Limited Emission Control System Warranty requires that you return your motorcycle to an authorized Kawasaki dealer for remedy under warranty. Please read the warranty carefully, and keep it valid by complying with the owner's obligations it contains.

You should keep a maintenance record for your motorcycle. To assist you in keeping this record, we have provided space on pages 138 through 142 of this manual where an authorized Kawasaki dealer, or someone equally competent, can record the maintenance. You should also retain copies of maintenance work orders, bills, etc., as verification of this maintenance.

TAMPERING WITH NOISE CONTROL SYSTEM PROHIBITED:

Federal law prohibits the following acts or the causing thereof: (1) the removal or rendering inoperative by any person other than for purposes of maintenance, repair, or replacement, of any device or element of design incorporated into any new vehicle for the purpose of noise control prior to its sale or delivery to the ultimate purchaser or while it is in use, or (2) the use of the vehicle after such device or element of design has been removed or rendered inoperative by any person.

Among those acts presumed to constitute tampering are the acts listed below:

- * Replacement of the original exhaust system or muffler with a component not in compliance with Federal regulations.
- * Removal of the muffler(s) or any internal portion of the muffler(s).
- * Removal of the air box or air box cover.
- * Modifications to the muffler(s) or air intake system by cutting, drilling, or other means if such modifications result in increased noise levels.

Periodic Maintenance Chart

K: Should be serviced by an authorized Kawasaki dealer.

*: For higher odometer readings, repeat at the frequency interval established here.

#: Service more frequently when operating in severe conditions: dusty, wet, muddy, high speed, or frequent starting/stopping.

1. Periodic Inspection (Engine Related Items)

Operation (Engine Items)	Frequency	*Odometer Reading km × 1000 (mile × 1000)							See Page
	Whichever comes first ↓ Every	1 (0.6)	6 (3.75)	12 (7.5)	18 (11.25)	24 (15)	30 (18.75)	36 (22.5)	
Air cleaner element - clean				●		●		●	88
Valve clearance - inspect				●		●		●	87

70 MAINTENANCE AND ADJUSTMENT

Operation (Engine Items)	Frequency	Whichever comes first →							*Odometer Reading km × 1000 (mile × 1000)	See Page
		↓	1 (0.6)	6 (3.75)	12 (7.5)	18 (11.25)	24 (15)	30 (18.75)		
Throttle control system (play, smooth return, no drag) - inspect	year	●		●		●		●	92	
Choke operation - inspect	year	●		●		●		●	—	
Idle speed - inspect		●		●		●		●	94	
K Fuel leak (fuel hose and pipe) - inspect	year	●		●		●		●	—	
K Fuel hoses damage - inspect	year	●		●		●		●	—	

Operation (Engine Items)	Frequency	Whichever comes first → ↓ *Odometer Reading km × 1000 (mile × 1000)							See Page
		Every	1 (0.6)	6 (3.75)	12 (7.5)	18 (11.25)	24 (15)	30 (18.75)	
K Fuel hoses installation condition - inspect	year	●		●		●		●	—
Air suction system damage - inspect				●		●		●	—

72 MAINTENANCE AND ADJUSTMENT

2. Periodic Inspection (Chassis Related Items)

Frequency	Whichever comes first →								*Odometer Reading km × 1000 (mile × 1000)	See Page
	↓	1	6	12	18	24	30	36		
Operation (Chassis Items)	Every	(0.6)	(3.75)	(7.5)	(11.25)	(15)	(18.75)	(22.5)		
Clutch and drive train:										
Clutch operation (play, engagement, disengagement) - inspect		•		•		•		•		95
Drive chain lubrication condition - inspect #	every 600 km (400 mile)								102	
Drive chain slack - inspect #	every 1 000 km (600 mile)								98	
Drive chain wear - inspect #				•		•		•		100

Frequency	Whichever comes first →								See Page
	*Odometer Reading km × 1000 (mile × 1000)								
Operation (Chassis Items)	Every	1 (0.6)	6 (3.75)	12 (7.5)	18 (11.25)	24 (15)	30 (18.75)	36 (22.5)	
Brake operation (effectiveness, play, drag) - inspect	year	●	●	●	●	●	●	●	103
Brake light switch operation - inspect		●	●	●	●	●	●	●	108
Suspensions:									
Rear shock absorber operation (damping and smooth stroke) - inspect				●		●		●	110
Front forks/rear shock absorber oil leak - inspect	year			●		●		●	—
K Uni-trak rocker arm bearings - lubricate						●			—

76 MAINTENANCE AND ADJUSTMENT

Operation (Chassis Items)	Frequency	Whichever comes first → ↓ *Odometer Reading km × 1000 (mile × 1000)							See Page
	Every	1 (0.6)	6 (3.75)	12 (7.5)	18 (11.25)	24 (15)	30 (18.75)	36 (22.5)	
K Uni-trak rocker arm operation - inspect				●		●		●	—
K Uni-trak tie rods operation - inspect				●		●		●	—
K Uni-trak tie rods bearings - lubricate						●			—
K Swing arm pivot - lubricate						●			—
Steering system:									
K Steering play - inspect	year	●		●		●		●	—

Frequency	Whichever comes first ↓	*Odometer Reading km × 1000 (mile × 1000)							See Page
		→	1 (0.6)	6 (3.75)	12 (7.5)	18 (11.25)	24 (15)	30 (18.75)	
Operation (Chassis Items)	Every								
K Steering stem bearings - lubricate	2 years					●			—
Electrical system:									
Lights and switches operation - inspect	year			●		●		●	—
Headlight aiming - inspect	year			●		●		●	117
Side stand switch operation - inspect	year			●		●		●	—
Engine stop switch operation - inspect	year			●		●		●	—
Chassis:									

78 MAINTENANCE AND ADJUSTMENT

Frequency	Whichever comes first ↓ Every	*Odometer Reading km × 1000 (mile × 1000)							See Page
		1 (0.6)	6 (3.75)	12 (7.5)	18 (11.25)	24 (15)	30 (18.75)	36 (22.5)	
Chassis parts - lubricate	year			●		●		●	121
Bolts and nuts tightness - inspect		●		●		●		●	127

3. Periodic Replacement

Change/Replacement Item	Frequency	Whichever comes first ↓ Every					*Odometer Reading km × 1000 (mile × 1000)	See Page
		1 (0.6)	12 (7.5)	24 (15)	36 (22.5)	48 (30)		
Air cleaner element # - replace	2 years						88	
Engine oil # - change	year	●	●	●	●	●	81	
Oil filter - replace	year	●	●	●	●	●	81	
K Fuel hoses - replace	4 years					●	—	
K Brake hoses - replace	4 years					●	—	
K Brake fluid (front and rear) - change	2 years			●		●	108	
K Rubber parts of master cylinder and caliper - replace	4 years					●	—	
Spark plug - replace			●	●	●	●	85	

Engine Oil

In order for the engine, transmission, and clutch to function properly, maintain the engine oil at the proper level, and change the oil and oil filter in accordance with the Periodic Maintenance Chart. Not only do dirt and metal particles collect in the oil, but the oil itself loses its lubricative quality if used too long.

WARNING

Motorcycle operation with insufficient, deteriorated, or contaminated engine oil will cause accelerated wear and may result in engine or transmission seizure, accident, and injury.

Oil Level Inspection

- Situate the motorcycle so that it is perpendicular to the ground.

- If the oil has just been changed, start the engine and run it for several minutes at idle speed. This fills the oil filter with oil. Stop the engine, then wait several minutes until the oil settles.

CAUTION

Racing the engine before the oil reaches every part can cause engine seizure.

- If the motorcycle has just been used, wait several minutes for all the oil to drain down.
- Check the engine oil level through the oil level gauge. With the motorcycle held level, the oil level should come up between the upper and lower level lines next to the gauge.

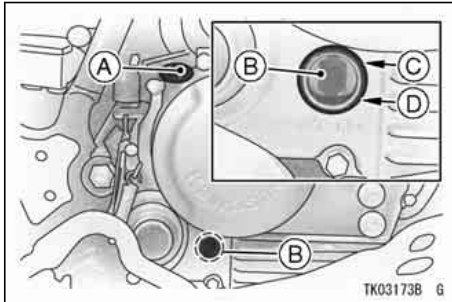

- A. Oil Filler Cap
- B. Oil Level Gauge
- C. Upper Level Line
- D. Lower Level Line

- If the oil level is too high, remove the excess oil through the oil filler opening using a syringe or some other suitable device.
- If the oil level is too low, add the oil to reach the correct level. Use the same type and brand of oil that is already in the engine.

Oil and/or Oil Filter Change

- Warm up the engine thoroughly, and then stop it.
- Set the motorcycle up on its side stand.
- Remove the bolt of the engine guard, and take off the engine guard.

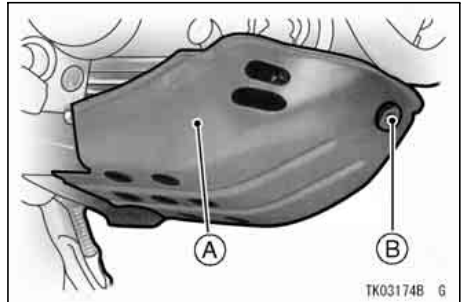

- A. Engine Guard
- B. Bolt

- Place an oil pan beneath the engine.
- Remove the engine oil drain plug.

82 MAINTENANCE AND ADJUSTMENT

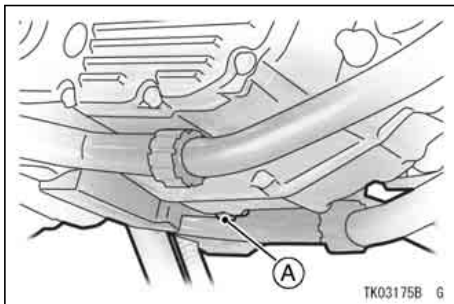

A. Drain Plug

- Let the oil completely drain with the motorcycle perpendicular to the ground.

! WARNING

Motor oil is a toxic substance. Dispose of used oil properly. Contact your local authorities for approved disposal methods or possible recycling.

- If the oil filter is to be changed, remove the oil filter cover bolts and take off the cover with O-ring.

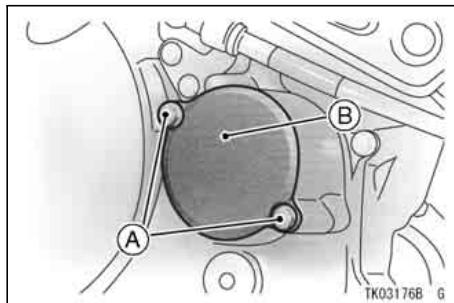

A. Bolts

B. Oil Filter Cover

- Replace the element with a new one.
- Put the spring and element into the right engine cover.

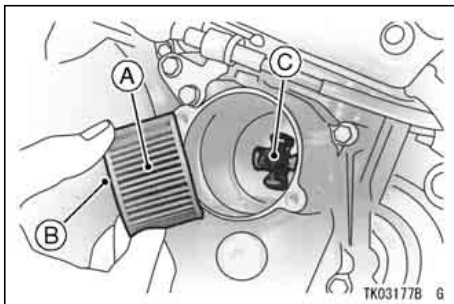

- A. Element
- B. Grommet
- C. Spring

- Apply a little engine oil to the grommet and O-ring, and install the oil filter cover and tighten its bolts.
- After the oil has completely drained out, install the engine oil drain plug

with its gasket. Proper torque for it is shown in the table.

NOTE

- *Replace the any gasket with a new one.*
- Fill the engine up to the upper level line with a good quality motor oil specified in the table.
- Start the engine.
- Check the oil level and for oil leakage.
- Install the engine guard.

Tightening Torque

Engine Oil Drain Plug:

15 N·m (1.5 kgf·m, 11 ft·lb)

NOTE

- *If a torque wrench is not available, this item should be serviced by a Kawasaki dealer.*

84 MAINTENANCE AND ADJUSTMENT

Recommended Engine Oil

Type: API SE, SF or SG
API SH, SJ, SL or SM with
JASO MA, MA1 or MA2

Viscosity: SAE 10W-40

NOTE

- Do not add any chemical additive to the oil. Oils fulfilling the above requirements are fully formulated and provide adequate lubrication for both the engine and the clutch.

Engine Oil Capacity

Capacity: 1.3 L (1.4 US qt)
[when filter is not removed]
1.4 L (1.5 US qt)
[when filter is removed]
1.5 L (1.6 US qt)
[when engine is completely dry]

Although 10W-40 engine oil is the recommended oil for most conditions, the oil viscosity may need to be changed to accumulate atmospheric conditions in your riding area.

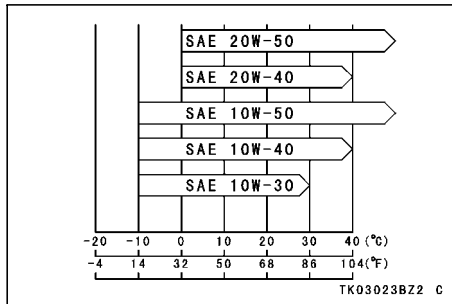

Spark Plugs

The standard spark plug is shown in the table. The spark plug should be taken out in accordance with the Periodic Maintenance Chart for cleaning, inspection, and resetting of the plug gap.

Maintenance

If the plug is oily or has carbon built up on it, have it cleaned, preferably in a sand-blasting device, and then clean off any abrasive particles. The plug may also be cleaned using a high-flash point solvent and a wire brush or other suitable tool. Measure the gap with a wire-type thickness gauge, and adjust the gap if incorrect by bending the outer electrode. If the spark plug electrodes are corroded or damaged, or if the insulator is cracked, replace the plug. Use the standard plug.

Spark Plug

Standard Plug	NGK CR8E, ND U24ESR-N
Plug Gap	0.7 ~ 0.8 mm (0.028 ~ 0.031 in.)
Tightening Torque	13 N·m (1.3 kgf·m, 115 in·lb)

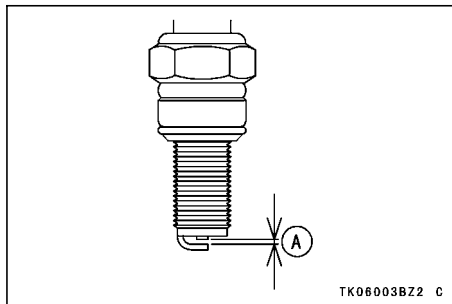

TK06003BZ2 C

A. Plug Gap

NOTE

- *If a torque wrench is not available, this item should be serviced by a Kawasaki dealer.*

CAUTION

For cold weather and/or low speed riding, a hotter spark plug shown in the table may be used for quicker warm-ups and more efficient engine operation. However, for normal temperatures and/or high speed use, the standard spark plug must be used to prevent engine damage.

Hotter Spark Plug

NGK CR7E

NOTE

- *When installing the spark plug cap onto the spark plug, fit the plug cap securely onto the spark plug, and pull the cap lightly to make sure that it is properly installed.*

Valve Clearance

Valve and valve seat wear decreases valve clearance, upsetting valve timing.

CAUTION

If valve clearance is left unadjusted, wear will eventually cause the valves to remain partly open, which lowers performance, burns the valves and valve seats, and may cause serious engine damage.

Valve clearance for each valve should be checked and adjusted in accordance with the Periodic Maintenance Chart.

Inspection and adjustment should be done only by a competent following the Service Manual.

Air Cleaner

A clogged air cleaner restricts the engine's air intake, increasing fuel consumption, reducing engine power, and causing spark plug fouling.

The air cleaner element must be cleaned in accordance with the Periodic Maintenance Chart. In dusty areas, the element should be cleaned more frequently than the recommended interval. After riding through rain or on muddy roads, the element should be cleaned immediately. The element should be replaced if it is damaged.

88 MAINTENANCE AND ADJUSTMENT

Element Removal

- Remove the right side cover.
- Unscrew the air cleaner element cap screws and bolt, then remove the air cleaner element cap.

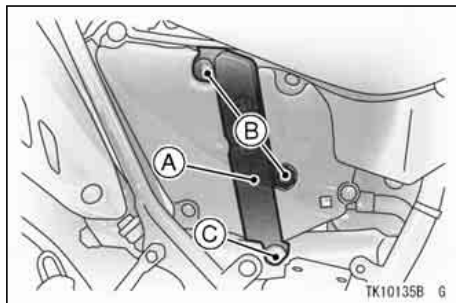

A. Air Cleaner Element Cap

B. Screws

C. Bolt

- Pull out the air cleaner element from the air cleaner housing.

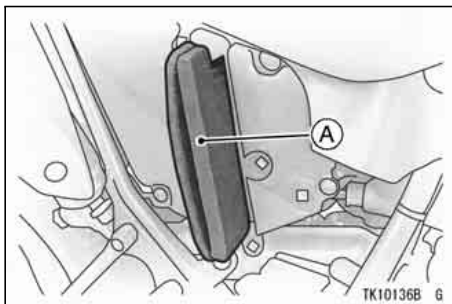

A. Element

- Remove the element from the frame.

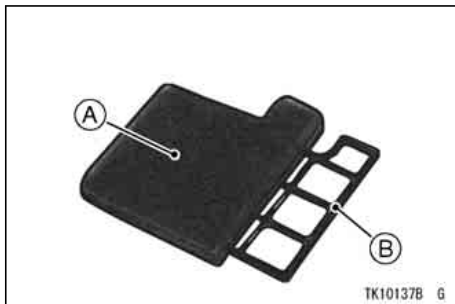

- A. Element
B. Frame

- Push a clean, lint-free towel into the air cleaner housing to keep dirt or other foreign material from entering.
- Inspect the element material for damage. If any part of the element is damaged, the element must be replaced.

! WARNING

If dirt or dust is allowed to pass through into the carburetor, the throttle may become stuck, possibly causing accident.

CAUTION

If dirt gets through into the engine, excessive engine wear and possibly engine damage will occur.

NOTE

- *Element installation is performed in the reverse order of removal.*

Element Cleaning

- Clean the element in a bath of a high-flash point solvent.

90 MAINTENANCE AND ADJUSTMENT

- Dry the element with compressed air or by squeezing it.
- After cleaning, saturate the element with SE, SF or SG class SAE 10W40 motor oil, squeeze out the excess oil, then wrap it in a clean rag and squeeze it as dry as possible. Be careful not to tear the element.

WARNING

Clean the element in a well ventilated area, and take care that there are no sparks or flame anywhere near the working area; this includes any appliance with a pilot light. Do not use gasoline or a low flash-point solvent to clean the element. A fire or explosion could result.

Oil Draining

- Inspect the transparent drain hoses located at the lower end of the air cleaner housing to see if any oil has run down from the air cleaner housing.

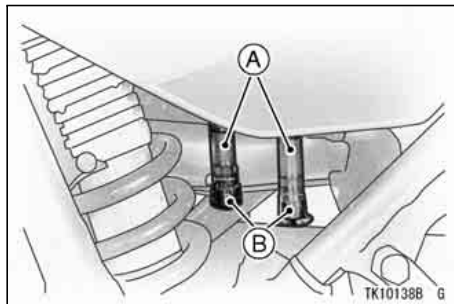

- A. Drain Hoses
- B. Plugs

- If there are any oil in the drain hoses, remove the plugs from the lower end of the drain hoses and drain the oil.

 **WARNING**

Be sure to install each plug in the drain hose after draining. Oil on tires will make them slippery and can cause an accident and injury.

Throttle Grip

The throttle grip controls the throttle valves. If the throttle grip has excessive play due to either cable stretch or maladjustment, it will cause a delay in throttle response, especially at low engine speed. Also, the throttle valves may not open fully at full throttle. On the other hand, if the throttle grip has no play, the throttle will be hard to control, and the idle speed will be erratic. Check the throttle grip play in accordance with the Periodic Maintenance Chart, and adjust the play if necessary.

92 MAINTENANCE AND ADJUSTMENT

Inspection

- Check that there is 2 ~ 3 mm (0.08 ~ 0.12 in.) throttle grip play when lightly turning the throttle grip back and forth.
- If there is improper play, adjust it.

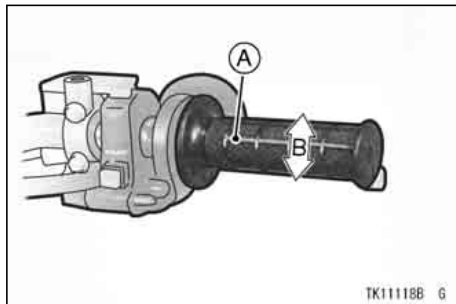

- A. Throttle Grip**
B. 2 ~ 3 mm (0.08 ~ 0.12 in.)

Adjustment

- Loosen the locknut at the upper end of the throttle cable, and turn the adjuster until the proper amount of throttle grip play is obtained.

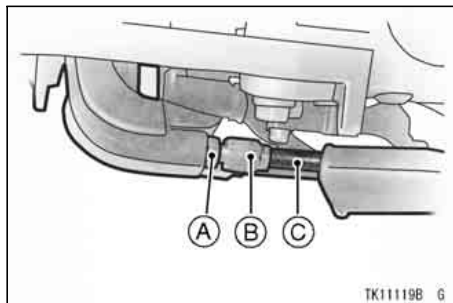

- A. Locknut**
B. Adjuster
C. Throttle Cable (Accelerator Cable)

- Tighten the locknut.
- If the throttle cable can not be adjusted by using the cable adjuster at the upper end of the throttle cable,

use the upper and lower nuts at the lower ends of the throttle cables.

- Loosen the locknut at the upper end of the throttle cable and turn in the adjuster fully.
- Tighten the locknut.
- Turn the upper and lower nuts at the lower end of the decelerator cable until there is no play when the throttle grip is completely closed. Tighten the nuts.
- Turn the upper and lower nuts at the lower end of the accelerator cable until 2 ~ 3 mm (0.08 ~ 0.12 in.) of throttle grip play is obtained. Tighten the nuts.

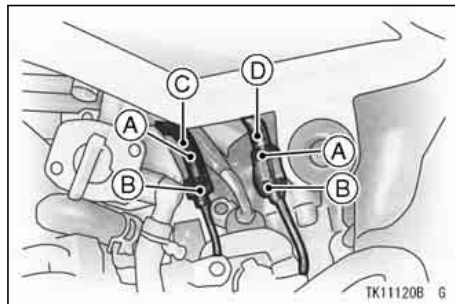

- A. Upper Nuts**
- B. Lower Nuts**
- C. Accelerator Cable**
- D. Decelerator Cable**

- If there is excess play, use the adjuster at the upper end of the throttle cable.

 **WARNING**

Operation with improperly adjusted, incorrectly routed, or damaged cables could result in an unsafe riding condition.

Carburetors

The following procedure covers the idle speed adjustment, which should be performed in accordance with the Periodic Maintenance Chart or whenever the idle speed is disturbed.

Adjustment

- Start the engine, and warm it up thoroughly.
- Adjust the idle speed to 1 250 ~ 1 350 r/min (rpm) by turning the idle adjusting screw.
- Open and close the throttle a few times to make sure that the idle speed does not change. Readjust if necessary.
- With the engine idling, turn the handlebar to each side. If handlebar movement changes the idle speed, the throttle cables may be improperly adjusted or incorrectly routed, or they

may be damaged. Be sure to correct any of these conditions before riding.

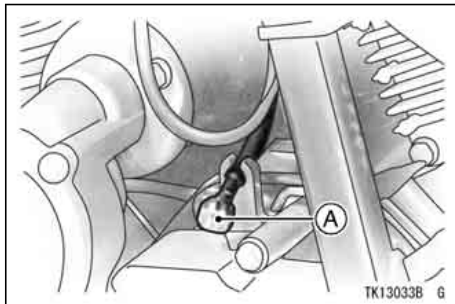

A. Idle Adjusting Screw

! WARNING

Operation with damaged cables could result in an unsafe riding condition.

Clutch

Due to friction plate wear and clutch cable stretch over a long period of use, the clutch must be adjusted in accordance with the Periodic Maintenance Chart.

! WARNING

To avoid a serious burn, never touch a hot engine or an exhaust pipe during clutch adjustment.

Inspection

- Check that the clutch lever has 2 ~ 3 mm (0.08 ~ 0.12 in.) of play as shown in the figure.

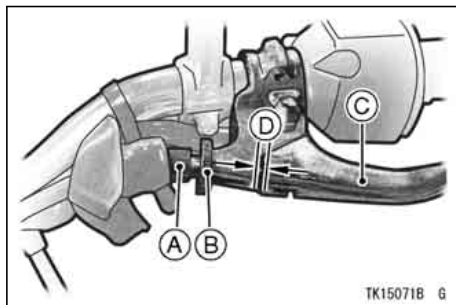

- A. Adjuster
- B. Locknut
- C. Clutch Lever
- D. 2 ~ 3 mm (0.08 ~ 0.12 in.)

If the play is incorrect, adjust the lever play as follows.

Adjustment

- Slide the dust cover at the clutch lever out of place.
- Loosen the locknut at the clutch lever.

- Turn the adjuster at the upper end of the cable so that the clutch lever will have 2 ~ 3 mm (0.08 ~ 0.12 in.) of play.

⚠ WARNING

Be sure the upper end of the clutch outer cable is fully seated in its fitting, or it could slip into place later, creating enough cable play to prevent clutch disengagement, resulting in a hazardous riding condition.

- Tighten the locknut.
- If it cannot be done, use the adjusting nut at the middle of the clutch cable.
- Loosen the locknut at the clutch lever.
- Turn the adjuster in all the way, then tighten the locknut.

- Loosen the locknut at the middle of the clutch cable, and turn the adjusting nut so that the clutch lever has 2 ~ 3 mm (0.08 ~ 0.12 in.) of play.

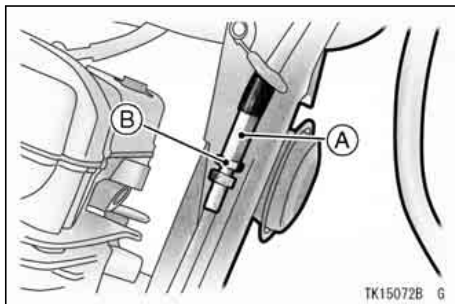

A. Adjusting Nut
B. Locknut

- Tighten the locknut.
- Slide the dust cover back into place.

NOTE

- After the adjustment is made, start the engine and check that the clutch does not slip and that it releases properly.

! WARNING

Do not run the engine in a closed area. Exhaust gases contain carbon monoxide; a colorless, odorless, poisonous gas. Breathing exhaust gas leads to carbon monoxide poisoning, asphyxiation, and death.

Drive Chain

The drive chain must be checked, adjusted, and lubricated in accordance with the Periodic Maintenance Chart for safety and to prevent excessive wear. If the chain becomes badly worn or maladjusted - either too loose or too tight - the chain could jump off the sprockets or break.

⚠ WARNING

A chain that breaks or jumps off the sprockets could snag on the engine sprocket or lock the rear wheel, severely damaging the motorcycle and causing it to go out of control.

Chain Slack Inspection

- Set the motorcycle up on its side stand.

- Rotate the rear wheel to find the position where the chain is tightest and measure the maximum chain slack by pulling up and pushing down the chain midway between the engine sprocket and rear wheel sprocket.

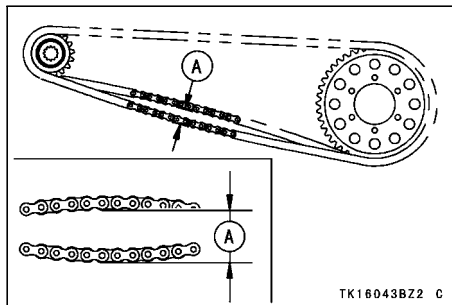

A. 35 ~ 55 mm (1.4 ~ 2.2 in.)

- If the drive chain is too tight or too loose, adjust it so that the chain slack will be within the standard value.

Drive Chain Slack

Standard	35 ~ 55 mm (1.4 ~ 2.2 in.)
----------	----------------------------

Chain Slack Adjustment

- Remove the cotter pin, and loosen the axle nut.
- Rotate the chain adjuster at each end of the swingarm to obtain the standard chain slack.

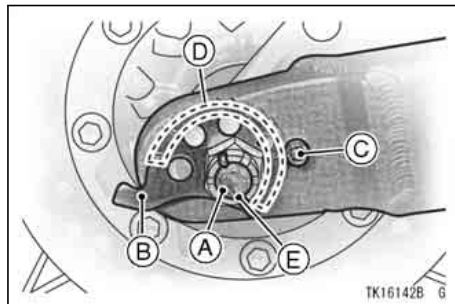

- A. Axle Nut
- B. Chain Adjuster
- C. Projection
- D. Numbers
- E. Cotter Pin

NOTE

- *Wheel alignment can also be checked using the straightedge or string method.*

 **WARNING**

Misalignment of the wheel will result in abnormal wear, and may result in an unsafe riding condition.

- Tighten the axle nut to the specified torque.

Tightening Torque

Axle Nut:
88 N·m (9.0 kgf·m, 65 ft·lb)

- Rotate the wheel, measure the chain slack again at the tightest position, and readjust if necessary.
- Insert a new cotter pin through the axle nut, and spread its ends.

- Check the rear brake (see the Brakes section).

 **WARNING**

If the axle nut is not securely tightened or the cotter pin is not installed, an unsafe riding condition may result.

Wear Inspection

- Stretch the chain taut either by using the chain adjusters, or by hanging a 10 kg (20 lb) weight on the chain.

- Measure the length of 20 links on the straight part of the chain from pin center of the 1st pin to pin center of the 21st pin. Since the chain may wear unevenly, take measurements at several places.
- If the length exceeds the service limit, the chain should be replaced.

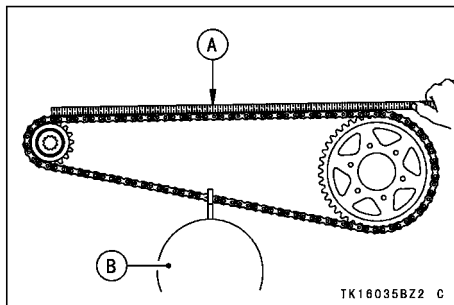

- A. Measure**
B. Weight

Drive Chain 20-Link Length

Service Limit: 323 mm (12.7 in.)

! WARNING

For safety, use only the standard chain. It is an endless type and should not be cut for installation; have it installed by an authorized Kawasaki dealer.

- Rotate the rear wheel to inspect the drive chain for damaged rollers, and loose pins and links.
- Also inspect the sprockets for unevenly or excessively worn teeth, and damaged teeth.

NOTE

- *Sprocket wear is exaggerated for illustration. See Service Manual for wear limits.*

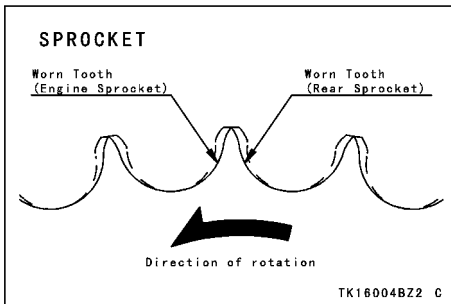

- If there is any irregularity, have the drive chain and/or the sprockets replaced by an authorized Kawasaki dealer.

Lubrication

Lubrication is also necessary after riding through rain or on wet roads, or any time that the chain appears dry. A heavy oil such as SAE 90 is preferred to a lighter oil because it will stay on the chain longer and provide better lubrication.

- Apply oil to the sides of the rollers so that it will penetrate to the rollers and bushings. Apply oil to the O-rings so that the O-rings will be coated with oil. Wipe off any excess oil.

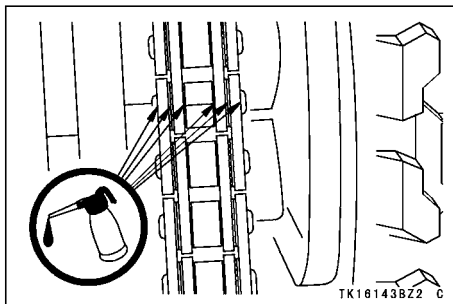

- If the chain is especially dirty, clean it using diesel oil or kerosine and then apply oil as described above.

Brakes

Disc and disc pad wear is automatically compensated for and has no effect on the brake lever or pedal action. So there are no parts that require adjustment on the brakes except brake lever play.

Front Brake Lever Play

The brake lever has 2 ~ 5 mm (0.08 ~ 0.20 in.) of play when the brake is lightly applied.

To adjust the brake lever play, loosen the locknut and turn the adjuster to either side. After adjustment, tighten the locknut securely and check the braking effectiveness.

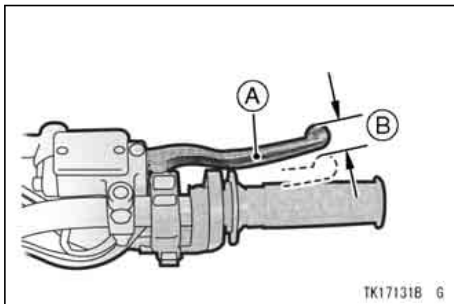

- A. Brake Lever
- B. 2 ~ 5 mm (0.08 ~ 0.20 in.)

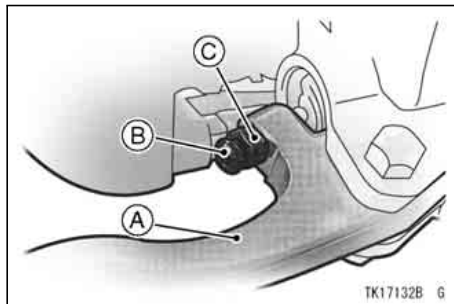

- A. Brake Lever
- B. Adjuster
- C. Locknut

! WARNING

If the brake lever or pedal feels mushy when it is applied, there might be air in the brake lines or the brake may be defective. Since it is dangerous to operate the motorcycle under such conditions, have the brake checked immediately.

Brake Wear Inspection

In accordance with the Periodic Maintenance chart, inspect the brakes for wear. For each front and rear disc brake caliper, if the thickness of either pad is less than 1 mm (0.04 in.), replace both pads in the caliper as a set. Pad replacement should be done by an authorized Kawasaki dealer.

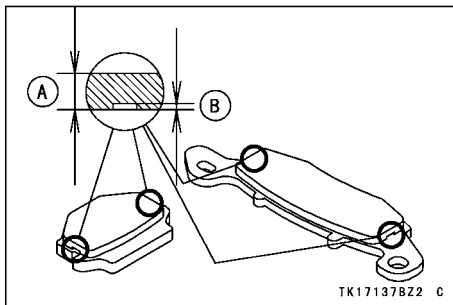

A. Lining Thickness

B. 1 mm (0.04 in.)

Disc Brake Fluid -

In accordance with the Periodic Maintenance Chart, inspect the brake fluid level in both the front and rear brake fluid reservoir and change the brake fluid. The brake fluid should also be changed if it becomes contaminated with dirt or water.

Fluid Requirement

Use heavy-duty brake fluid only from a container marked DOT3 or DOT4.

NOTE

- Brake fluid of DOT4 is installed in the brake system when shipped.

CAUTION

Do not spill brake fluid onto any painted surface.

Do not use fluid from a container that has been left open or that has been unsealed for a long time.

Check for fluid leakage around the fittings.

Check brake hose for damage.

Fluid Level Inspection

- The brake fluid level in the front brake fluid reservoir must be kept above the line (lower level line) next to the gauge and that in the rear brake fluid reservoir (located under the right side cover) must be kept between the upper and lower level lines (reservoirs held horizontal).

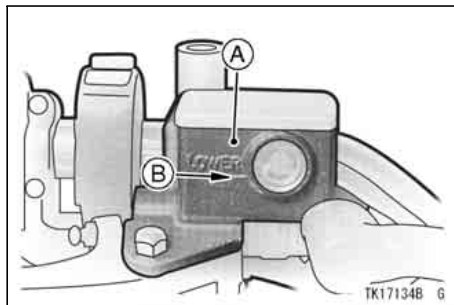

A. Front Brake Fluid Reservoir
B. Lower Level Line

- If the fluid level in either reservoir is lower than the lower level line, check for fluid leaks in the brake lines, and fill the reservoir to the upper level line. Inside the front brake fluid reservoir is a stepped line showing the upper level line.

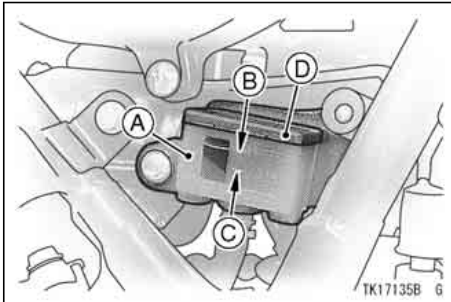

- A. Rear Brake Fluid Reservoir**
- B. Upper Level Line**
- C. Lower Level Line**
- D. Cap**

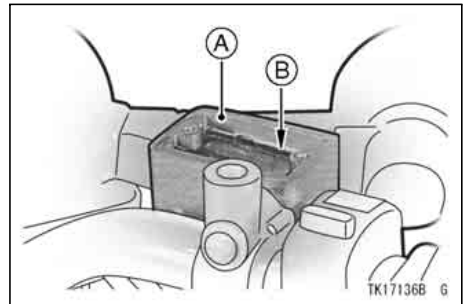

- A. Front Brake Fluid Reservoir**
- B. Upper Level Line**

 **WARNING**

Do not mix two brands of brake fluid. Change the brake fluid in the brake line completely if the brake fluid must be refilled but the type and brand of the brake fluid that is already in the reservoir are unidentified.

Fluid Change

Have the brake fluid changed by an authorized Kawasaki dealer.

Brake Light Switches

When either the front or rear brake is applied, the brake light goes on. The front brake light switch requires no adjustment, but the rear brake light switch should be adjusted in accordance with the Periodic Maintenance Chart.

Inspection

- Turn the ignition key to "ON".
- The brake light should go on when the front brake is applied.
- If it does not, ask your authorized Kawasaki dealer to inspect the front brake light switch.

- Check the operation of the rear brake light switch by depressing the brake pedal. The brake light should go on after about 10 mm (0.4 in.) of pedal travel.

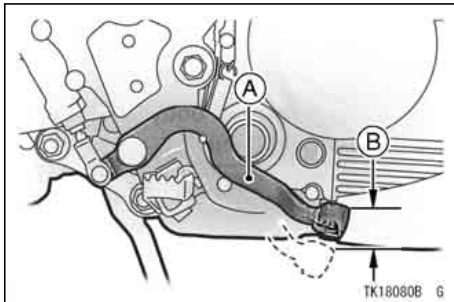

- A. Brake Pedal
- B. 10 mm (0.4 in.)

- If it does not, adjust the rear brake light switch.

Adjustment

- To adjust the rear brake light switch, move the switch up or down by turning the adjusting nut.

CAUTION

To avoid damaging the electrical connections inside the switch, be sure that the switch body does not turn during adjustment.

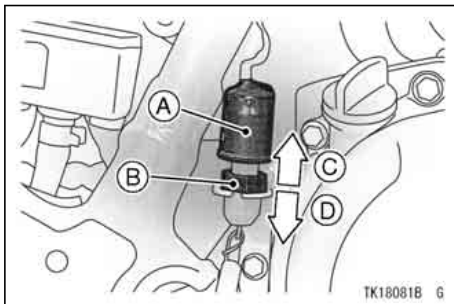

- A. Rear Brake Light Switch
- B. Adjusting Nut
- C. Lights sooner
- D. Lights later

Rear Shock Absorber

The rear shock absorber can be adjusted by changing the spring preload and rebound damping force for various riding and loading conditions. Before making any adjustments, however, read the following procedures.

Spring Preload Adjustment

The spring adjusting nut on the rear shock absorber can be adjusted.

If the spring action feels too soft or too stiff, have it adjusted by an authorized Kawasaki dealer.

Rebound Damping Force Adjustment

The rebound damping force adjuster at the lower end of the rear shock absorber has 20 adjustment clicks.

- First turn the rebound damping force adjuster all the way clockwise with a screwdriver to make the damping force greatest.

- Turn the adjuster counterclockwise to decrease damping force.

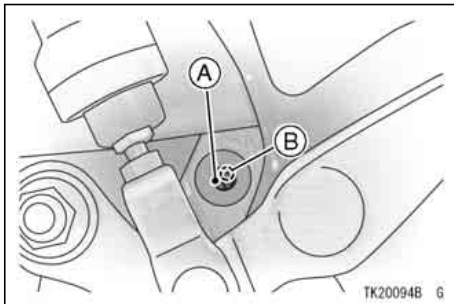

A. Rebound Damping Adjuster

B. Mark

The standard setting position of the rebound damping force adjuster for an average-build rider of 68kg (150 lb) with no passenger and no accessories are as follows.

Rebound Damping Force Adjuster	7 turns out*
--------------------------------	--------------

* out from the fully seated position

Wheels

Tires -

Payload and Tire Pressure

Failure to maintain proper inflation pressures or observe payload limits for your tires may adversely affect handling and performance of your motorcycle and can result in loss of control. The maximum recommended load in addition to vehicle weight is 165 kg (364 lb), including rider, passenger, baggage, and accessories.

- Check the tire pressure often, using an accurate gauge.

NOTE

- *Measure the tire pressure when the tires are cold (that is, when the motorcycle has not been ridden more than a mile during the past 3 hours).*

- *Tire pressure is affected by changes in ambient temperature and altitude, and so the tire pressure should be checked and adjusted when your riding involves wide variations in temperature or altitude.*



A. Tire Pressure Gauge

Tire Air Pressure (when cold)

Front	Up to 165 kg (364 lb) Load	150 kPa (1.50 kgf/cm ² , 21 psi)
Rear	Up to 97.5 kg (215 lb) Load	150 kPa (1.50 kgf/cm ² , 21 psi)
	97.5 ~ 165 kg (215 ~ 364 lb) Load	175 kPa (1.75 kgf/cm ² , 25 psi)

Tire Wear, Damage

As the tire tread wears down, the tire becomes more susceptible to puncture and failure. An accepted estimate is that 90% of all tire failures occur during the last 10% of tread life (90 % worn). So it is false economy and unsafe to use the tires until they are bald.

- In accordance with the Periodic Maintenance Chart, measure the depth of the tread with a depth gauge, and replace any tire that has worn down to the minimum allowable tread depth.

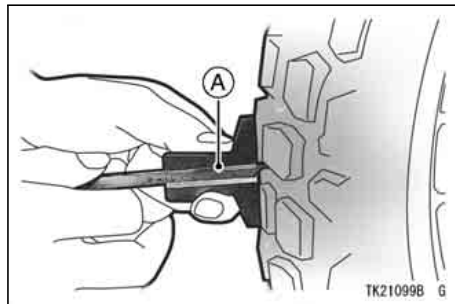
A. Tire Depth Gauge
Minimum Tread Depth

Front	2 mm (0.08 in.)
Rear	2 mm (0.08 in.)

114 MAINTENANCE AND ADJUSTMENT

- Visually inspect the tire for cracks and cuts, replacing the tire in case of bad damage. Swelling or high spots indicate internal damage, requiring tire replacement.
- Remove any imbedded stones or other foreign particles from the tread.

NOTE

- *Have the wheel balance inspected whenever a new tire is installed.*

WARNING

To ensure safe handling and stability, use only the recommended standard tires for replacement, inflated to the standard pressure.

Standard Tire

Front	Size: 2.75-21 45P BRIDGESTONE "TRAIL WING-301"
Rear	Size: 4.10-18 59P BRIDGESTONE "TRAIL WING-302"

WARNING

Use the same manufacturer's tires on both front and rear wheels.

 **WARNING**

New tires are slippery and may cause loss of control and injury. A break-in period of 160 km (100 miles) is necessary to establish normal tire traction. During break-in, avoid sudden and maximum braking and acceleration, and hard cornering.

Battery

The battery installed in this motorcycle is a sealed type, so it is not necessary to check the battery electrolyte level or add distilled water.

The sealing strip should not be pulled off once the specified electrolyte has been installed in the battery for initial service.

Since the electrical system of this motorcycle is designed to use only a sealed battery, do not replace it with a conventional battery.

CAUTION

Never remove the sealing strip, or the battery can be damaged. Do not install a conventional battery in this motorcycle, or the electrical system cannot work properly.

NOTE

- If you charge the sealed battery, never fail to observe the instructions shown in the label on the battery.

! WARNING

Battery posts, terminals and related accessories contain lead and lead compounds. Wash hands after handling.

Battery Removal

- Remove the left side cover.
- Disconnect the leads from the battery, first from the (-) terminal and then the (+) terminal.

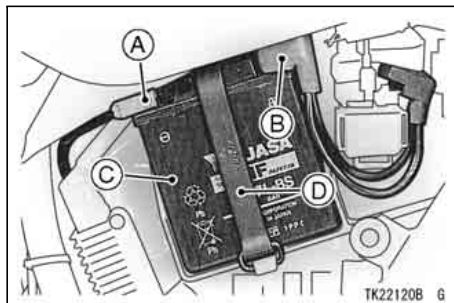

- A. (-) Terminal
- B. (+) Terminal
- C. Battery
- D. Band

- Remove the battery band, and take the battery out of the battery case.

- Clean the battery using a solution of baking soda and water. Be sure that the lead connections are clean.

Battery Installation

- Put the battery in the battery case.
- Connect the capped lead to the (+) terminal, and then connect the black lead to the (-) terminal.
- Put a light coat of grease on the terminals to prevent corrosion.
- Cover the (+) terminal with its protective cap.
- Reinstall the parts removed.

Headlight Beam

Horizontal Adjustment

The headlight beam is adjustable horizontally. If not properly adjusted horizontally, the beam will point to one side rather than straight ahead.

- Turn the horizontal adjusting screw on the headlight rim in or out until the beam points straight ahead.

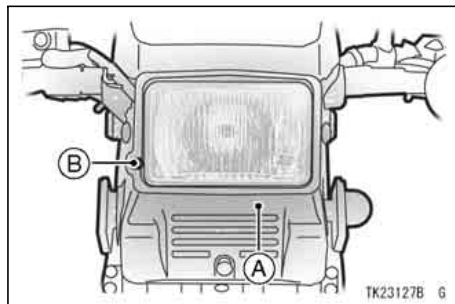

- A. Vertical Adjusting Screw**
B. Horizontal Adjusting Screw

118 MAINTENANCE AND ADJUSTMENT

Vertical Adjustment

The headlight beam is adjustable vertically. If adjusted too low, neither low nor high beam will illuminate the road far enough ahead. If adjusted too high, the high beam will fail to illuminate the road close ahead, and the low beam will blind oncoming driver.

- Turn the vertical adjusting screw on the headlight rim in or out to adjust the headlight vertically.

NOTE

- *On high beam, the brightest point should be slightly below horizontal. The proper angle is 0.4 degrees below horizontal. This is a 50 mm (2 in.) drop at 7.6 m (25 ft) measured from the center of the headlight, with the motorcycle on its wheels and the rider seated.*

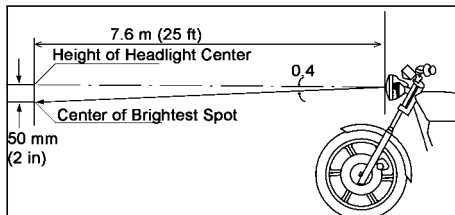

CAUTION

When handling the quartz-halogen bulbs, never touch the glass portion with bare hands. Always use a clean cloth. Oil contamination from hands or dirty rags can reduce bulb life or cause the bulb to explode.

Fuses

The main fuse is mounted on the starter relay located to the left side of the battery. The fuse case is located to the left side of the starter relay. If a fuse fails during operation, inspect the electrical system to determine the cause, and then replace it with a new fuse of proper amperage.

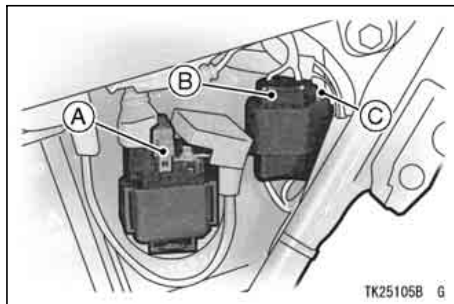

- A. Main Fuse (20 A)
- B. Fuse Case
- C. Spare Fuse

! WARNING

Do not use any substitute for the standard fuse.

Replace the blown fuse with a new one of the correct capacity, as specified on the fuse case.

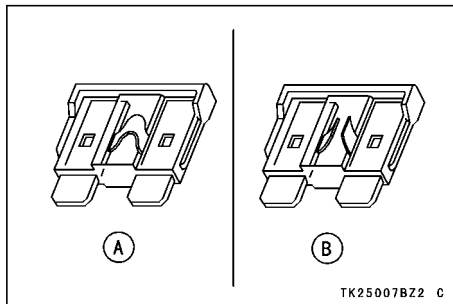

A. Normal
B. Failed

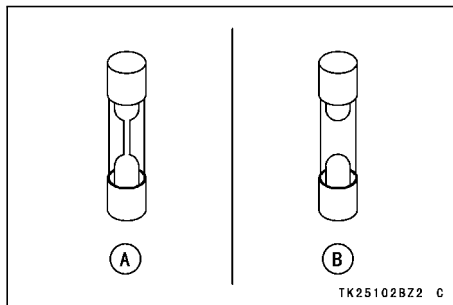

A. Normal
B. Failed

General Lubrication

Lubricate the points shown below, with either motor oil or regular grease, in accordance with the Periodic Maintenance Chart or whenever the vehicle has been operated under wet or rainy conditions.

Before lubricating each part, clean off any rusty spots with rust remover and wipe off any grease, oil, dirt, or grime.

NOTE

- *A few drops of oil are effective to keep bolts and nuts from rusting and sticking. This makes removal easier. Badly rusted nuts, bolts, etc., should be replaced with new ones.*

Apply motor oil to the following pivots -

- Side Stand
- Clutch Lever
- Front Brake Lever
- Rear Brake Pedal

Lubricate the following cables with a pressure cable lubber -

- Clutch Inner Cable
- Throttle Inner Cables

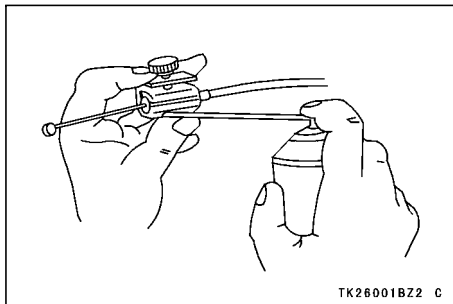

Apply grease to the following points -

- Clutch Inner Cable Upper End
- Throttle Inner Cable Upper Ends

* Grease the lower part of the inner cable sparingly.

NOTE

- *After connecting the cables, adjust them.*

Cleaning Your Motorcycle

General Precautions

Frequent and proper care of your Kawasaki motorcycle will enhance its appearance, optimize overall performance, and extend its useful life. Covering your motorcycle with a high quality, breathable motorcycle cover will help protect its finish from harmful UV rays, pollutants, and reduce the amount of dust reaching its surfaces.

- Be sure the engine and exhaust are cool before washing.
- Avoid applying degreaser to seals, brake pads, and tires.
- Always use non-abrasive wax and cleaner/polisher.
- Avoid all harsh chemicals, solvents, detergents, and household cleaning products such as ammonia-based window cleaners.

- Gasoline, brake fluid, and coolant will damage the finish of painted and plastic surfaces: wash them off immediately.
 - Avoid wire brushes, steel wool, and all other abrasive pads or brushes.
 - Use care when washing the headlight cover, and other plastic parts as they can easily be scratched.
 - Avoid using pressure washers; water can penetrate seals and electrical components and damage your motorcycle.
 - Avoid spraying water in delicate areas such as in air intakes, carburetors, brake components, electrical components, muffler outlets, and fuel tank openings.
- Mix a mild neutral detergent (designed for motorcycles or automobiles) and water in bucket. Use a soft cloth or sponge to wash your motorcycle. If needed, use a mild degreaser to remove any oil or grease build up.
 - After washing, rinse your motorcycle thoroughly with clean water to remove any residue (residue from the detergent can damage parts of your motorcycle).
 - Use a soft cloth to dry your motorcycle. As you dry, inspect your motorcycle for chips and scratches. Do not let the water air dry as this can damage the painted surfaces.
 - Start the engine and let it idle for several minutes. The heat from the engine will help dry moist areas.
 - Carefully ride your motorcycle at a slow speed and apply the brakes several times. This helps dry the

Washing Your Motorcycle

- Rinse your bike with cold water from a garden hose to remove any loose dirt.

124 MAINTENANCE AND ADJUSTMENT

brakes and restores them to normal operating performance.

- Lubricate the drive chain to prevent rusting.

NOTE

- *After riding in an area where the roads are salted or near the ocean, immediately wash your motorcycle with cold water. Do not use warm water as it accelerates the chemical reaction of the salt. After drying, apply a corrosion protection spray on all metal and chrome surfaces to prevent corrosion.*

Painted Surfaces

After washing your motorcycle, coat painted surfaces, both metal and plastic, with a commercially available motorcycle/automotive wax. Wax should be applied once every three months or as conditions require. Avoid surfaces with "satin" or "flat" finishes. Always use non-abrasive products and apply them according to the instructions on the container.

Plastic Parts

After washing use a soft cloth to gently dry plastic parts. When dry, treat the headlight lens, and other non-painted plastic parts with an approved plastic cleaner/polisher product.

CAUTION

Plastic parts may deteriorate and brake if they come in contact with chemical substances or household cleaning products such as gasoline, brake fluid, window cleaners, thread-locking agents, or other harsh chemicals. If a plastic part comes in contact with any harsh chemical substance, wash it off immediately with water and a mild neutral detergent, and then inspect for damage. Avoid using abrasive pads or brushes to clean plastic parts, as they will damage the part's finish.

Chrome and Aluminum

Chrome and uncoated aluminum parts can be treated with a chrome/aluminum polish. Coated aluminum

should be washed with a mild neutral detergent and finished with a spray polish. Aluminum wheels, both painted and unpainted can be cleaned with special non-acid based wheel spray cleaners.

Leather, Vinyl, and Rubber

If your motorcycle has leather accessories, special care must be taken. Use a leather cleaner/treatment to clean and care for leather accessories. Washing leather parts with detergent and water will damage them, shortening their life.

Vinyl parts should be washed with the rest of the motorcycle, then treated with a vinyl treatment.

The sidewalls of tires and other rubber components should be treated with a rubber protectant to help prolong their useful life.

 **WARNING**

Special care must be taken not to get any rubber protectant on the tire's tread surface when treating tires. This may decrease the tire's ability to maintain contact with the road surface causing the rider to lose control.

Bolt and Nut Tightening

In accordance with the Periodic Maintenance Chart, it is very important to check the tightness of the bolts and nuts listed here. Also, check to see that each cotter pin is in place and in good condition. Please ask your authorized Kawasaki dealer for torque values.

1. Front Fender Mounting Bolts
2. Front Fork Clamp Bolts
3. Clutch Lever Holder Bolts
4. Handlebar Clamp Bolts
5. Steering Stem Head Bolt
6. Cylinder Head Bolts
7. Rear Shock Absorber Mounting Bolts and Nuts
8. Caliper Mounting Bolts
9. Spokes
10. Engine Mounting Bolts and Nuts
11. Shift Pedal Bolt
12. Swingarm Pivot Shaft Bolt

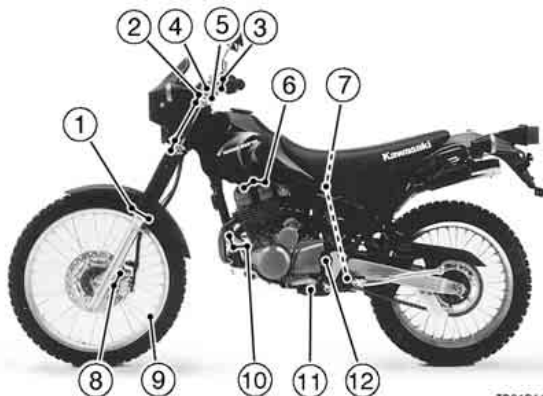

128 MAINTENANCE AND ADJUSTMENT

- 13. Muffler Mounting Bolts
- 14. Brake Lever Holder Bolt
- 15. Rear Axle Nut
- 16. Exhaust Pipe Holder Nuts
- 17. Front Axle Nut



TD01B117 G

STORAGE

Preparation for Storage:

- Clean the entire vehicle thoroughly.
- Run the engine for about five minutes to warm the oil, shut it off and drain the engine oil.

WARNING

Motor oil is a toxic substance. Dispose of used oil properly. Contact your local authorities for approved disposal methods or possible recycling.

- Put in fresh engine oil.
- Empty the fuel from the fuel tank, and empty the carburetors by unscrewing the drain screw at the float bowl. (If left in for a long time, the fuel will break down and could clog the carburetor.)

 **WARNING**

Gasoline is extremely flammable and can be explosive under certain conditions. Turn the ignition key to "OFF". Do not smoke. Make sure the area is well ventilated and free from any source of flame or sparks; this includes any appliance with a pilot light.

Gasoline is a toxic substance. Dispose of gasoline properly. Contact your local authorities for approved disposal methods.

- Remove the empty fuel tank, pour about 250 mL (1/2 pint) of motor oil into the tank, roll the tank around to coat the inner surfaces thoroughly, and pour out the excess oil.
- Remove the spark plugs and spray fogging oil, such as Kawasaki K-Kare Fogging Oil (part number K61030-002), directly into each cylinder. Turn the engine over several times with the starter button to coat the cylinder walls. Install the spark plug.

 **WARNING**

Do not lean over the engine when performing this procedure. An air/oil mist may be forcibly ejected from the spark plug hole and could get into your eyes. If you do get some in your eyes, wash your eyes immediately with liberal amounts of clean, fresh water. Consult a physician as soon as possible.

- Reduce tire pressure by about 20%.
- Set the motorcycle on a box or stand so that both wheels are raised off the ground. (If this cannot be done, put boards under the front and rear wheels to keep dampness away from the tire rubber.)
- Spray oil on all unpainted metal surfaces to prevent rusting. Avoid getting oil on rubber parts or in the brakes.
- Lubricate the drive chain and all the cables.
- Remove the battery, and store it where it will not be exposed to direct sunlight, moisture, or freezing temperatures. During storage it should be given a slow charge (one ampere or less) about once a month. Keep the battery well charged especially during cold weather.
- Tie plastic bags over the muffler to prevent moisture from entering.
- Put a cover over the motorcycle to keep dust and dirt from collecting on it.

132 STORAGE

Preparation after Storage:

- Remove the plastic bag from the muffler.
 - Install the battery in the motorcycle and charge the battery if necessary.
 - Make sure the spark plug is tight.
 - Fill the fuel tank with fuel.
 - Check all the points listed in the Daily Safety Checks section.
 - Lubricate the points listed in the General Lubrication section.
- 

TROUBLESHOOTING GUIDE

Engine Does Not Start -

Starter Motor Won't Turn

- Engine stop switch off
- Clutch lever not pulled in and transmission not in neutral
- Fuse blown
- Battery leads do not make good electrical contact with battery terminals
- Battery discharged

Engine Cranks, But Won't Start

- No fuel in tank
- Fuel line clogged
- Fuel broken down
- Choke is not used when engine is cold
- Engine flooded
- Spark plugs not in good contact

- Spark plugs fouled or wet
- Incorrect spark plug gap
- Battery discharged

Engine Stalls -

Just When Shifting Into 1st Gear

- Side stand has been left down
- Clutch does not properly disengage

While Riding

- Choke is used too long after moving off
- No fuel in tank
- Fuel tap is turned off
- Fuel tank air vent is obstructed
- Overheating
- Battery discharged

OWNER SATISFACTION

(For Products Sold in the Continental United States of America Only)

Your satisfaction is important to your authorized Kawasaki dealer and to Kawasaki Motors Corp., U.S.A. If you have a problem concerning warranty or service, please take the following action:

Contact the owner and/or service manager of your authorized Kawasaki dealer. Fully explain your problem and ask for assistance in resolving the situation. The OWNER of the dealership is concerned with your satisfaction and your future business. For this reason the owner is in the best position to assist you. Also, all warranty and service matters are handled and resolved through the authorized Kawasaki dealer network.

If you are unsatisfied after working with your Kawasaki dealer and feel you still require further assistance, write to the address below. Please be certain to provide the model, product identification number, mileage or hours of use, accessories, dates that events occurred and what action has been taken by both you and your dealer. Include the name and address of the dealership. To assist us in resolving your inquiry, please include copies of related receipts and any other pertinent information including the names of the dealership personnel with whom you have been working in the resolution of your problem.

Upon receipt of your correspondence we will contact the dealership and work with them in resolving your problem.

In order to provide a permanent record, all warranty and service resolutions take place only through written correspondence.

Please send your correspondence to:
CONSUMER RELATIONS
KAWASAKI MOTORS CORP., U.S.A.
P. O. Box 25252
SANTA ANA, CA. 92799-5252
(949) 460-5688

REPORTING SAFETY DEFECTS

(For Products Sold in the Continental United States of America Only)

If you believe that your vehicle has a defect which could cause a crash or could cause injury or death, you should immediately inform the National Highway Traffic Safety Administration (NHTSA) in addition to notifying Kawasaki Motors Corporation, U.S.A.

If NHTSA receives similar complaints, it may open an investigation, and if it finds that a safety defect exists in a group of vehicles, it may order a recall and remedy campaign. However, NHTSA cannot become involved in individual problems between you, your dealer, or Kawasaki Motors Corporation, U.S.A.

To contact NHTSA, you may either call the Auto Safety Hotline toll-free at 1-800-424-9393 (or 366-0123 in Washington, D.C. area) or write to: NHTSA, U.S. Department of Transportation, Washington, D.C. 20590. You can also obtain other information about motor vehicle safety from the Hotline.

ENVIRONMENTAL PROTECTION

To protect our environment, properly discard used batteries, tires, engine oil, or other vehicle components that you might dispose of in the future. Consult your authorized Kawasaki dealer or local environmental waste agency for their proper disposal procedures.

MAINTENANCE RECORD

Owner Name.....

Address

Phone Number

Engine Number

Vehicle Number.....

Selling Dealer Name

Phone Number

Warranty Start Date

Note: Keep this information and a spare key in a secure location.

Date	Odometer Reading	Maintenance Performed	Dealer Name	Dealer Address

LABEL INFORMATION

(1)

IMPORTANT BREAK-IN INSTRUCTIONS
To ensure proper vehicle performance, you must follow the recommendation in the owner's manual regarding break-in maintenance at 800km(500mi) and break-in operation up to 1,600km(1,000mi).

56040-1008

TE03057CN9 C

(2)

TIRE AND LOAD DATA				
The stability and handling characteristics of this motorcycle could become unsafe by the use of improper tire inflation pressures, overworn tires, unsuitable replacement tires, or overloading. When tire tread wears down to the limit, replace the tire with only the standard tire. Maintain the inflation pressure specified.				
	Air Pressure (Cold)	Size & Make Type	Minimum Tread Depth	
Front	Up to 185kg Load (364 lbs)	150 kPa (1.50kg/cm ² /1psi)	BRIDGESTONE 2.75-21 45P TRAIL WING-301	2 mm (0.08 in)
Rear	Up to 175kg Load (315 lbs)	150 kPa (1.50kg/cm ² /1psi)	BRIDGESTONE 4.10-18 59P TRAIL WING-302	2 mm (0.08 in)

56053-1076

TE03058C S

144 LABEL INFORMATION

(3)

IMPORTANT DRIVE CHAIN INFORMATION

To prevent an accident and/or damage to the motorcycle, the drive chain must be properly maintained. It should be lubricated every 600km(400mi) and adjusted as often as necessary to keep chain slack at about 35~55mm(1.4~2.2in)measured midway between sprockets on the lower chain run with the motorcycle on the side stand. The standard chain is an Enuma EK520LV0 with estimated service life of 10000~40000km(6,200~25,000mi), depending on the severity of use and the frequency of lubrication and adjustment. For safety, replace the chain with only the standard chain any time it wears to over 323mm(12.7in), measured over a 20-link portion pulled straight with 10kg of tension. See the Owner's Manual for chain information.

56033-1364

TE03059CZ5 C

(4)

VEHICLE EMISSION CONTROL INFORMATION	
ENGINE FAMILY CODE -----	_____
PERMEATION FAMILY -----	_____
MODEL(S) -----	_____
EXHAUST EMISSION CONTROL SYSTEM -----	_____
TUNE UP SPECIFICATIONS	
IGNITION TIMING	10° BTDC AT 1300 RPM
IDLE SPEED	1300 ± 50 RPM IN NEUTRAL
IDLE AIR FUEL MIXTURE SETTING	NO ADJUSTMENT
VALVE CLEARANCE (ENGINE COLD)	INTAKE : 0.10-0.19 MM (0.0039-0.0075 IN) EXHAUST : 0.14-0.23 MM (0.0055-0.0091 IN)
SPARK PLUG	CR8E(NGK), U24ESR-N(DENSO) SPARK PLUG GAP : 0.7-0.8 MM (0.028-0.031 IN)
FUEL	GASOLINE WITH RESEARCH OCTANE NO. (RON) 91 MIN.
ENGINE OIL	SERVICE RATING: API SE, SF OR SG API SH, SJ, SL OR SM WITH JASO MA, MA1 OR MA2 VISCOSITY : SAE 10W-40 SEE THE OWNER'S MANUAL FOR ENGINE OIL INFORMATION.
THIS VEHICLE CONFORMS TO U.S. EPA REGULATIONS APPLICABLE TO XXXX MODEL YEAR NEW MOTORCYCLES. KAWASAKI HEAVY INDUSTRIES, LTD.	
	

59464-1685

TE03061C29 C

146 LABEL INFORMATION



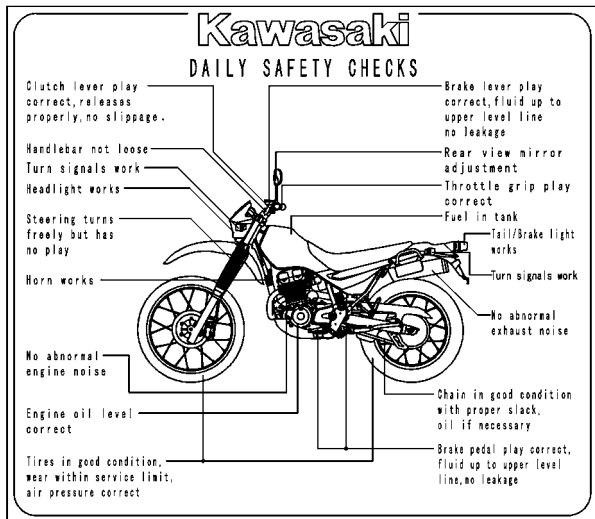



(5)



56033-1088

TE03060C29 C

(6)

⚠ DANGER/POISON		
 <p>SHIELD EYES EXPLOSIVE GASES CAN CAUSE BLINDNESS OR INJURY</p>	 <p>NO • SPARKS • FLAMES • SMOKING</p>	 <p>SULFURIC ACID CAN CAUSE BLINDNESS OR SEVERE BURNS</p>
<p>FLUSH EYES IMMEDIATELY WITH WATER</p>  <p>GET MEDICAL HELP FAST</p>		
KEEP OUT OF REACH OF CHILDREN		
<p>IN U.S.A., YUASA INC. SERVICED BY : READING, PA. 19612</p>		
		
 <p>RECYCLE Pb</p>		

148 LABEL INFORMATION

(7)

ENGINE OIL AND OIL FILTER

Engine Oil Change--when filter is not removed: 1.3 liters(1.4 US qt)
when filter is removed: 1.4 liters(1.5 US qt)

Engine Oil Type: API SE, SF or SG
: API SH or SJ with JASO MA
SAE 10W-40

See Owner's Manual for engine oil / filter information and change intervals.

56033-1370

TE03082CZ5 C

 WARNING

Engine exhaust, some of its constituents, and certain vehicle components contain or emit chemicals known to the State of California to cause cancer and birth defects or other reproductive harm.

NOTICE

THIS PRODUCT HAS BEEN MANUFACTURED FOR USE IN A REASONABLE AND PRUDENT MANNER BY A QUALIFIED OPERATOR AND AS A VEHICLE ONLY.

(8)/(9)

USE ONLY DOT3 OR 4 BRAKE
FLUID FROM A SEALED CONTAINER.
CLEAN FILLER CAP
BEFORE REMOVING.
WARNING
UTILISER DU LIQUIDE
DE FREIN DOT3 OU 4.

TE03792BN9 C

(11)

MFD. BY KAWASAKI HEAVY INDUSTRIES, LTD.
DATE: THIS VEHICLE CONFORMS
TO ALL APPLICABLE FEDERAL MOTOR VEHICLE
SAFETY STANDARDS IN EFFECT ON THE DATE
OF MANUFACTURE SHOWN ABOVE.
GVWR 646 LBS. GAWR F 206 LBS. WITH 2.75
-21 45P TIRE, J21X1.60 RIM, AT 21 PSI.
COLD. GAWR R 440 LBS. WITH 4.10-18 59P
TIRE, J18X2.15 RIM, AT 25 PSI. COLD.
JKAKLMG1XXXXXXXXXX
MOTOR CYCLE (KL250G) MADE IN JAPAN

59464-1237

TE03063CN9 C

(10)

MOTORCYCLE NOISE EMISSION CONTROL INF.

THIS XXXX MOTORCYCLE MEETS EPA NOISE EMISSION
REQUIREMENTS BY THE FEDERAL TEST PROCEDURE.
MODIFICATIONS WHICH CAUSE THIS MOTORCYCLE TO
EXCEED FEDERAL NOISE STANDARDS ARE PROHIBITED
BY FEDERAL LAW. SEE OWNER'S MANUAL. (KL250G)
MODEL SPECIFIC CODE:KAW3970250
SEE VEHICLE IDENTIFICATION NUMBER ON STEERING HEAD
NOISE LIMIT/CLOSING RPM:80DBA/7126RPM

59464-1686

TE03064CN9 C

KL250G9



KAWASAKI HEAVY INDUSTRIES, LTD.
Consumer Products & Machinery Company

Part No. 99987-1565

Printed in Japan